

iBoard®



Scan for
Installation Video

iBoard® by APS

PART#: IB-045C&H

READ INSTRUCTIONS CAREFULLY BEFORE STARTING INSTALLATION. REMOVE CONTENTS FROM BOX AND VERIFY ALL PARTS ARE PRESENT. ASSISTANCE IS RECOMMENDED.

*BODY FRAME MOUNT
*DRILLING IS REQUIRED

Fastener Size	Tightening Torque (ft-lbs)	Required
6mm	6-7	X
8mm	16-18	√
10mm	31-32	X
12mm	56-58	√
14mm	92-94	X

PART LIST

Driver Side Step Bar

Front



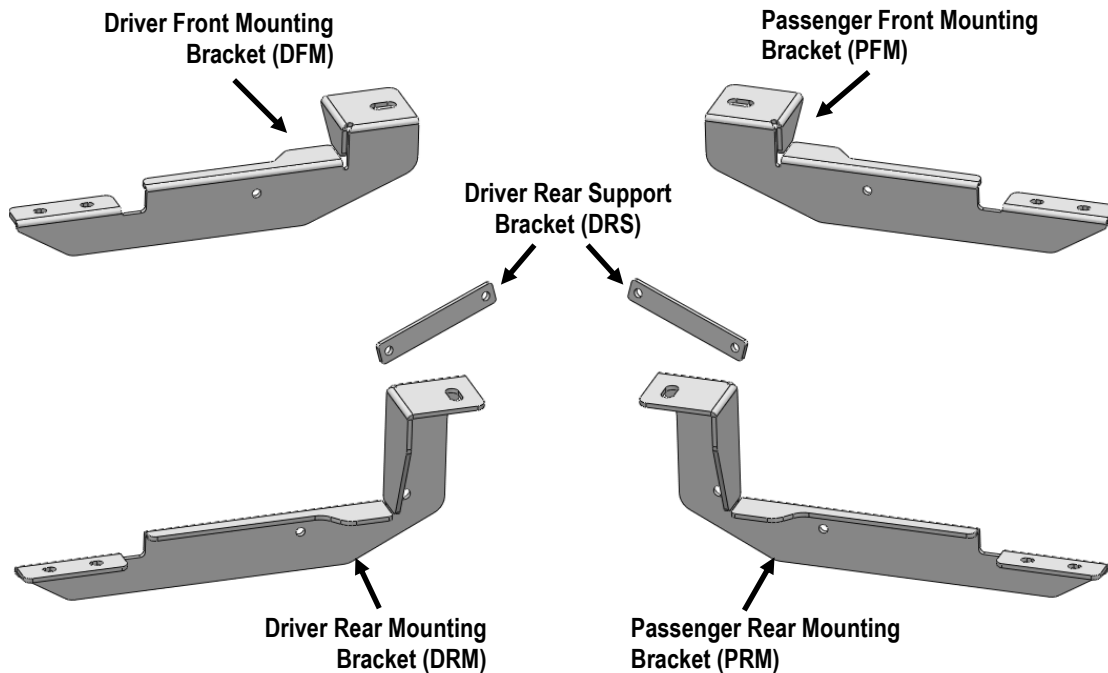
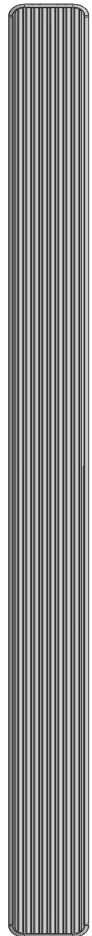



Passenger Side Step Bar



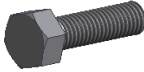

Customer Support: info@iboardauto.com



Hardware Package A (For Bracket Installation)					
Item	QTY	Description	Item	QTY	Description
1#	4	M12X1.75-110mm Hex Bolts	5#	8	M8 Flat Washers
2#	4	M12 Large Flat Washers	6#	4	M8 Lock Washers
3#	4	M12 Lock Washers	7#	4	M8 Hex Nuts
4#	4	M8X1.25-25mm Hex Bolts			

						
1#	2#	3#	4#	5#	6#	7#

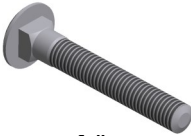
Hardware Package B (For Stainless Steel Step Bar Installation)					
Item	QTY	Description	Item	QTY	Description
1#	8	M8X1.25-35mm Carriage Bolts	3#	8	M8 Nylon Lock Nuts
2#	8	M8 Large Flat Washers	4#	4	Sliders (Packed with Step Bars)

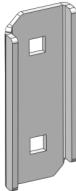
			
1 #	2 #	3 #	4 #



STEP 1

Start installation from the driver side front of the vehicle. Remove the front body mount bolt from body mount.

Select the Driver Front Mounting Bracket (**DFM**). Bolt the mounting bracket to the vehicle with (1) M12X1.75-110mm Hex Bolt, (1) M12 Lock Washer, and (1) M12 Large Flat Washer, (**Fig 1**). Do not fully tighten hardware at this time.

STEP 2

Move to driver side rear of the vehicle. Repeat **Step 1** for Driver Rear Mounting Bracket (**DRM**) installation, (**Fig 1**). Do not fully tighten hardware at this time.

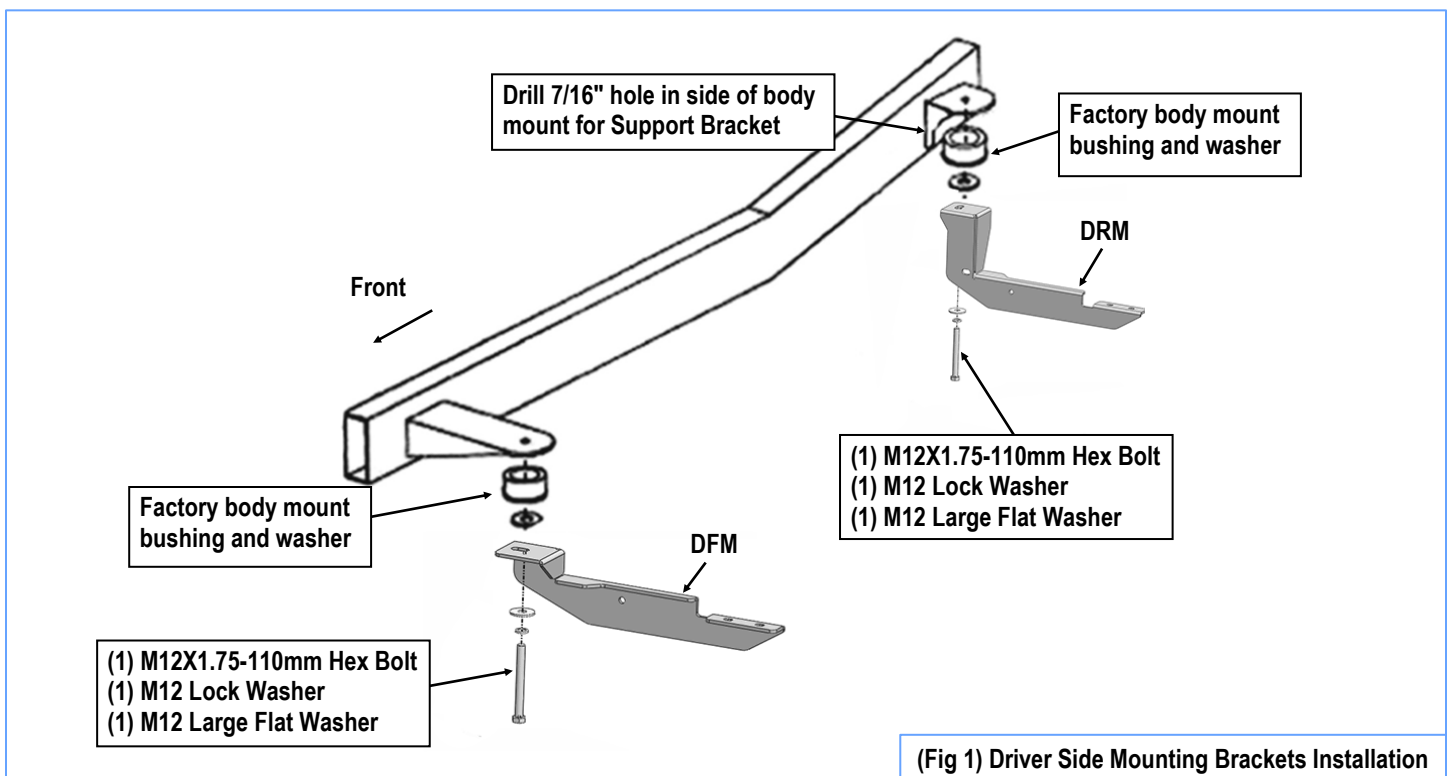

STEP 3

Select the Driver Rear Support Bracket (**DRS**). Attach the Support Bracket to the front side of the Driver Rear Mounting Bracket using the included (1) M8X1.25-25mm Hex Bolt, (1) M8 Lock Washer, (2) M8 Flat Washers and (1) M8 Hex Nut, (**Fig 2**). Do not fully tighten hardware at this time.



STEP 4

Line up the opposite end of the Support Bracket with the gusset on the steel body mount housing. Using the remaining hole in the Support Bracket as a template, mark and carefully drill a 7/16" hole through the side of the body mount bracket., (Fig 1).

IMPORTANT! Any cutting or drilling tool may break or shatter. Government regulations require safety glasses & equipment at all times when cutting or drilling.

Attach the Support Bracket to the drilled hole with (1) M8X1.25-25mm Hex Bolt, (1) M8 Lock Washer, (2) M8 Flat Washers and (1) M8 Hex Nut, (Fig 2). Do not fully tighten hardware at this time.

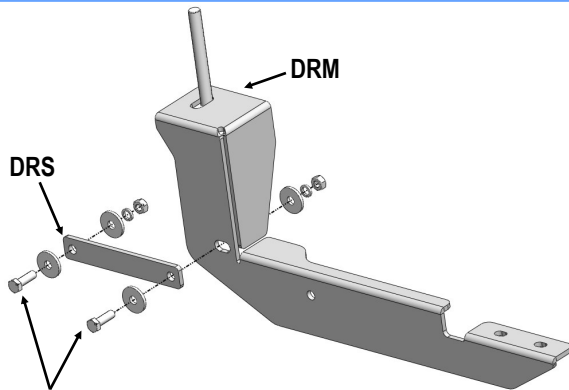

(2) M8X1.25-25mm Hex Bolts
(4) M8 Flat Washers
(2) M8 Lock Washers
(2) M8 Hex Nuts

(Fig 2) Driver Rear Support Bracket (DRS) Installation

STEP 5

Once all (2) Driver side mounting brackets are installed, then proceed to the Step Bar installation. (Figs 3 & 4)

(1) Select (1) Slider and (2) M8X1.25-35mm Carriage Bolts;

(2) Install (2) M8X1.25-35mm Carriage Bolts in (1) Slider.

(3) Slide the Slider (with carriage bolts) to the **Step Bar**.

(4) Repeat to install the other (1) slider to the step bar.

(5) Attach the Step Bar (with the Sliders) onto the installed mounting brackets. Position the Sliders to the installed brackets. Secure the Step Bar to the installed Brackets by using (4) M8 Large Flat Washers and (4) M8 Nylon Lock Nuts and (2) Sliders, (Fig 4). Do not fully tighten hardware at this time.

Note: The Sliders are packed with the Step Bars.

Level and adjust the Step Bar and fully tighten all hardware.

Repeat **Steps 1-5** for the other side Step Bar installation. **The installation is completed!!!**

Attention

Do periodic inspections to the installation to make sure that all hardware is secure and tight.

In order to protect your bars/boards, please use mild soap/non-abrasive products for cleaning only.

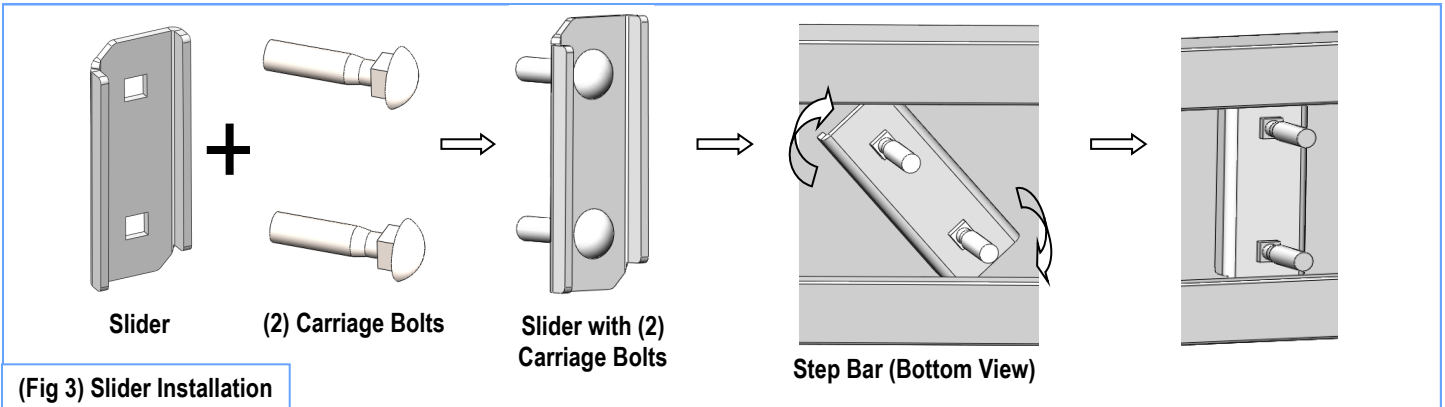

(Fig 3) Slider Installation

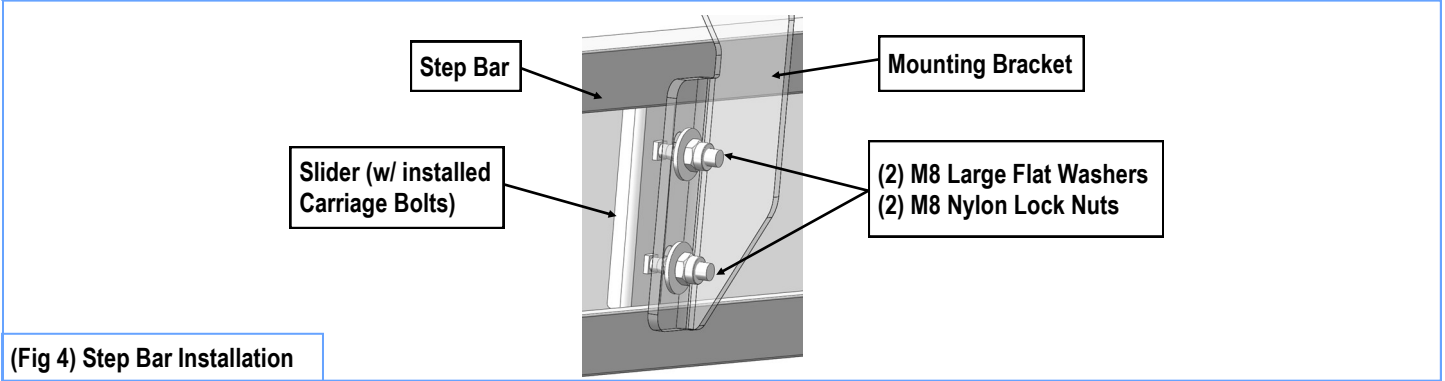

(Fig 4) Step Bar Installation