



iBoard® by APS

PART#: IB-178L C&H

READ INSTRUCTIONS CAREFULLY BEFORE STARTING INSTALLATION. REMOVE CONTENTS FROM BOX AND VERIFY ALL PARTS ARE PRESENT. ASSISTANCE IS RECOMMENDED.

*ROCKER PANEL MOUNT
*DRILLING MAY BE REQUIRED

Fastener Size	Tightening Torque (ft-lbs)	Required
6mm	6-7	√
8mm	16-18	√
10mm	31-32	√
12mm	56-58	X
14mm	92-94	X

PART LIST

Driver Side Step Bar

Front

Passenger Side Step Bar

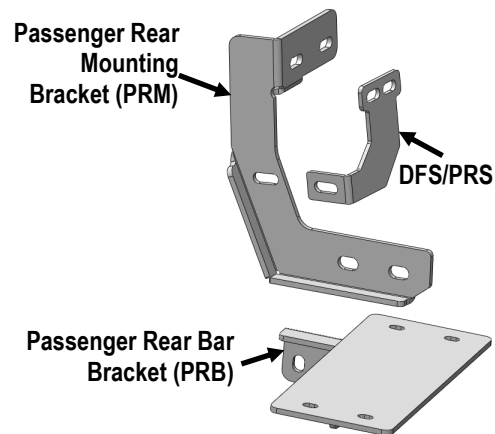
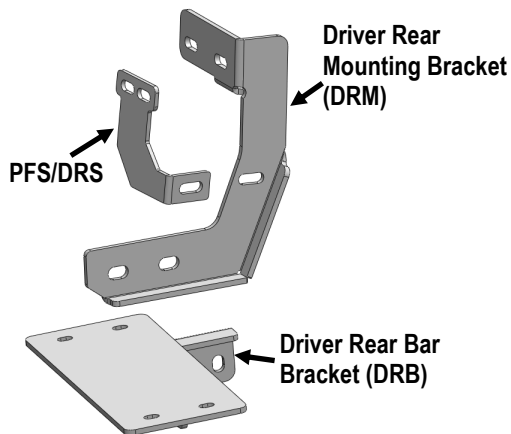
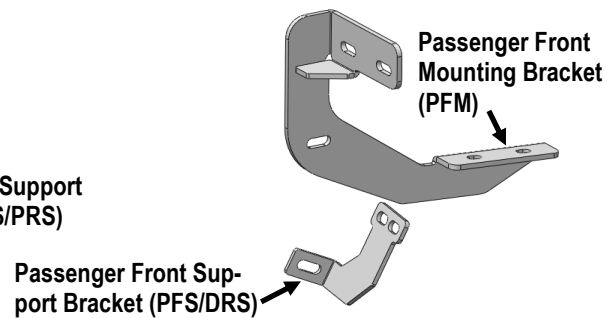
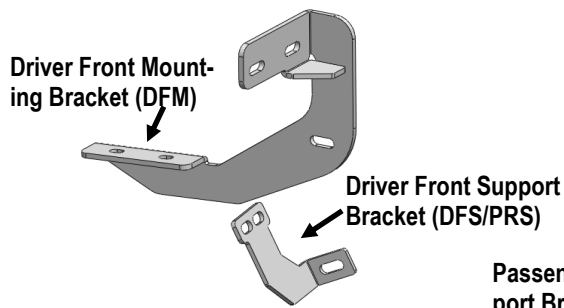
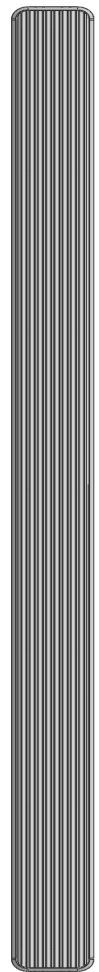
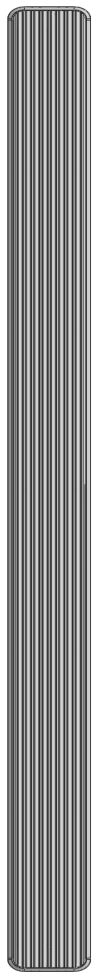



Hardware Package A (For Bracket Installation)

Item	QTY	Description	Item	QTY	Description
1#	4	M8 Bolt/Nut Plates	8#	16	M8 Large Flat Washers
2#	4	M10 Plastic Washer	9#	8	M8 Lock Washers
3#	4	M10X1.5-30 Hex Bolts	10#	4	M8X1.25 Hex Nuts
4#	8	M10 Flat Washers	11#	4	M8X1.25 Nylon Lock Nuts
5#	4	M10 Lock Washers	12#	8	M6X1-25 Hex Bolts
6#	4	M10X1.5 Hex Nuts	13#	16	M6 Large Flat Washers
7#	12	M8X1.25-30 Hex Bolts	14#	8	M6X1 Nylon Lock Nuts

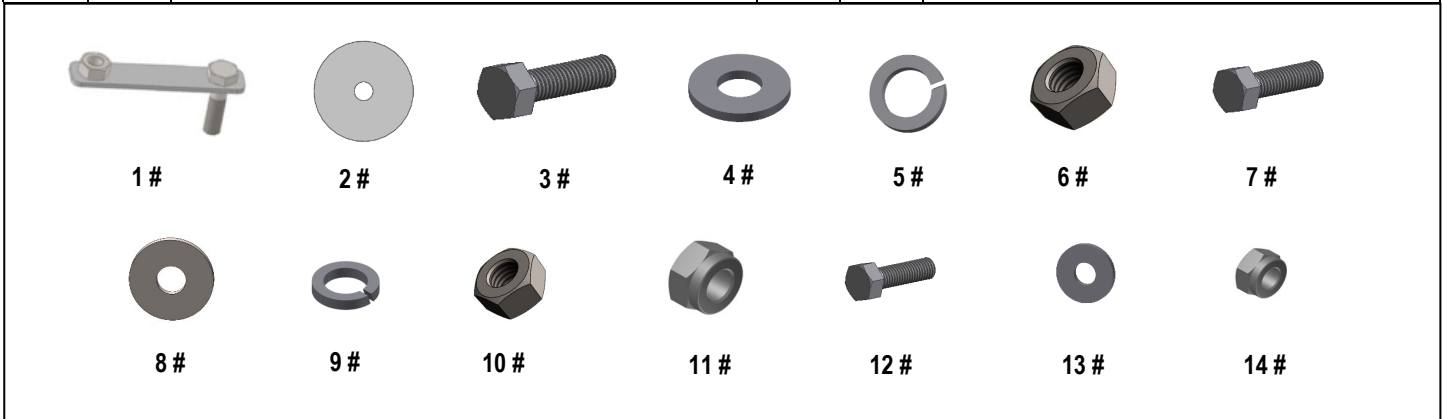

Hardware Package B (For Stainless Steel Step Bar Installation)

Item	QTY	Description	Item	QTY	Description
1#	12	M8X1.25-35mm Carriage Bolts	3#	12	M8 Nylon Lock Nuts
2#	12	M8 Large Flat Washers	4#	6	Sliders (Packed with Step Bars)

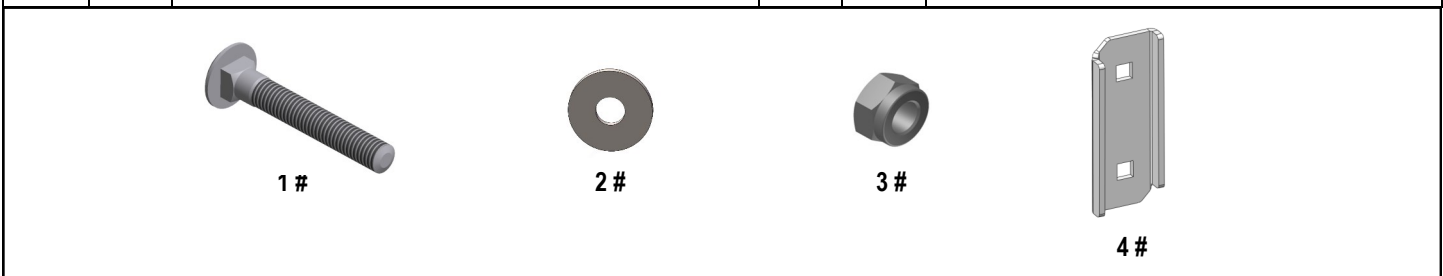



STEP 1

Start installation from the driver side front mounting location of the vehicle. Remove the sealing tapes covering the factory holes, (Fig 1).

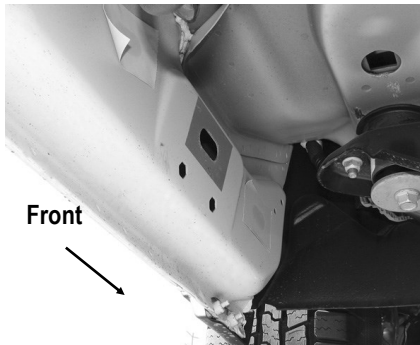

(Fig 1) 2009-Mid 2015 Driver Front Mounting Location
(No Factory Holes In Pinch Weld on Some Models)

STEP 2

Determine the correct procedure to attach the driver Front Mounting Brackets for your model/year:

Models without factory threaded inserts on body panel:

a. Select (1) M8 Bolt Plate, (Fig 2). Partially thread the M8X1.25-30 Hex Bolt into the welded nut on the Bolt Plate until it is flush with the welded nut, (Fig 3). Use the Hex Bolt as a handle and insert the Nut/Bolt Plate into the oval hole, (Fig 4). Feed the threaded bolt on the Bolt Plate through one of the hex shaped factory holes. Thread (1) Plastic Washer onto the welded bolt and down tight against the body panel, (Fig 5). **NOTE:** The Plastic Washer is designed to keep the Bolt Plate out falling into the body panel and to aid in Bracket installation.

b. Attach (1) Driver Front Mounting Bracket (DFM) to the welded bolt of the M8 Bolt Plate on the driver side front location with (1) M8 Flat Washer, (1) M8 Lock Washer and (1) M8X1.25 Hex Nut, (Fig 6a).

Remove the M8X1.25-30 Hex Bolt from the Bolt Plate. Hold the welded bolt and rotate the Bolt Plate until the welded nut lines up with the remaining hole on the Mounting Bracket. Do not fully tighten hardware at this time.

c. Secure the Driver Front Mounting Bracket to the welded nut on the M8 Bolt Plate with (1) M8X1.25-30 Hex Bolt, (1) M8 Lock Washer and (1) M8 Flat Washer (Fig 6b). Do not fully tighten hardware at this time.



(Fig 2) M8 Bolt Plate (**NOTE:** M8 Bolt Plate is not required on models with threaded inserts on body panel)

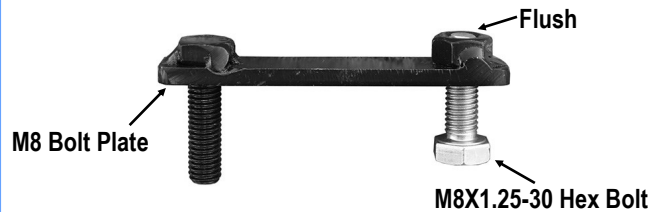

(Fig 3) Thread (1) M8X1.25-30 Hex Bolt into the welded nut on the plate. (Stop when bolt reaches end of nut as pictured)

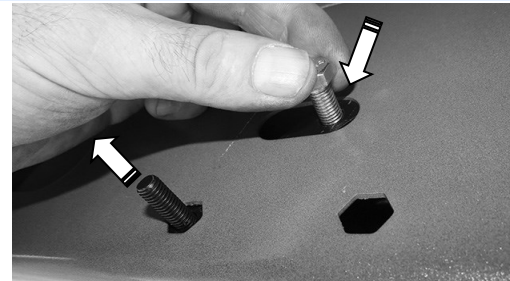

(Fig 4) Use the loose Hex Bolt as a handle. Insert the Bolt Plate into the oval hole and feed the threaded bolt out either factory hex shaped hole. **IMPORTANT:** Do not let go of the hex bolt until after Plastic Washer has been threaded onto bolt (Fig 5).

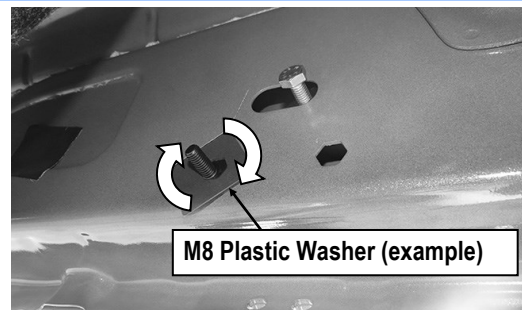

(Fig 5) Thread Plastic Washer onto the welded bolt to hold Bolt Plate in position

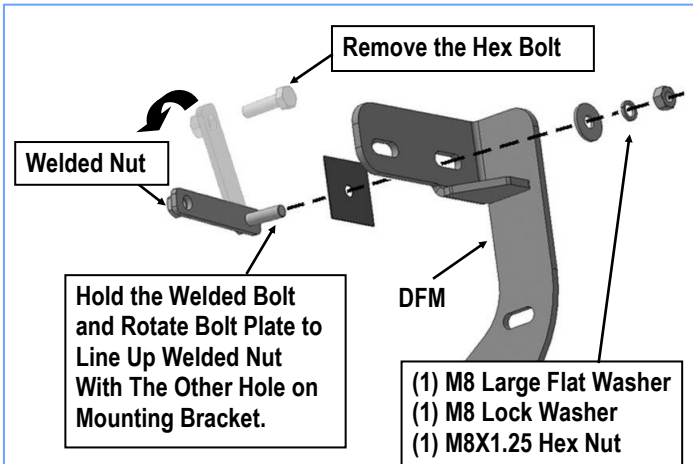

(Fig 6a) Attach Driver Front Mounting Bracket to Welded Bolt on the M8 Bolt Plate

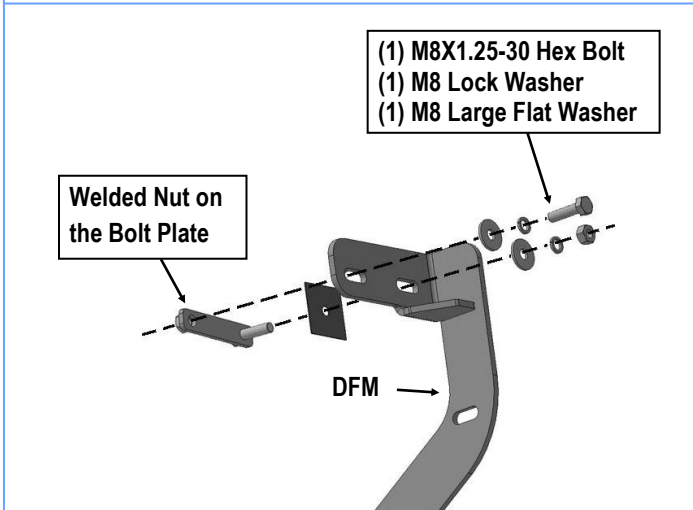

(Fig 6b) Secure the Mounting Bracket to the Welded Nut on the M8 Bolt Plate

Models with factory threaded inserts on body panel:
Attach Driver Front Mounting Bracket (DFM) to the threaded inserts with (2) M8x1.25-30 Hex Bolts, (2) M8 Lock Washers and (2) M8 Large Flat Washers, (Fig 7 & 8). Do not fully tighten hardware at this time.

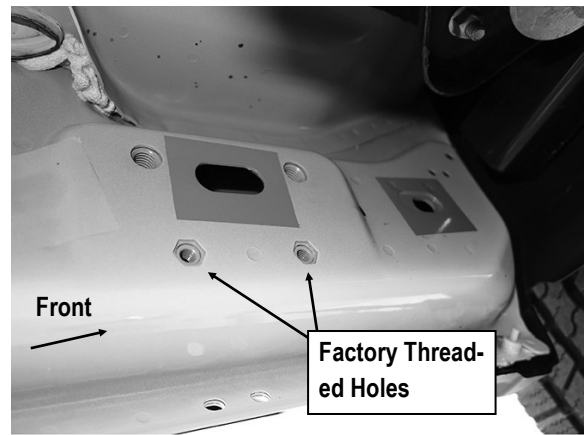

(Fig 7) Driver Side Front Mounting Location (Mid 2015-On, An Example Of Models With Factory Installed Threaded Inserts)

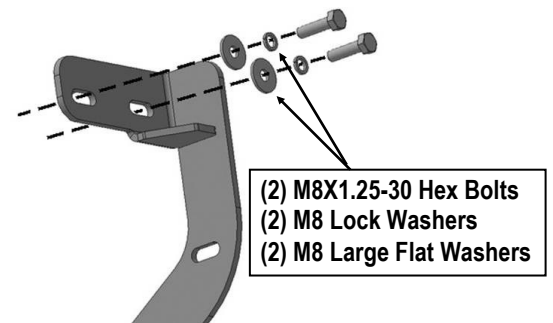

(Fig 8) Driver Front Mounting Bracket Installed (For Models With Factory Installed Threaded Inserts. Bolt Plate Not Required)

STEP 3

Attach the Driver Front Support Bracket (DFS/PRS) to the Driver Front Mounting Bracket (DFM) with (1) M8X1.25-30 Hex Bolt, (2) M8 Large Flat Washers and (1) M8X1.25 Nylon Lock Nut, (Fig 9). Rotate the support bracket to the back of the pinch weld. Line up the slots on the Support Bracket with the (2) factory holes on the pinch weld. Attach the Bracket to the back of the pinch weld with (2) M6X1-25 Hex Bolts, (4) M6 Large Flat Washers and (2) M6X1 Nylon Lock Nuts, (Fig 10). Do not fully tighten hardware at this time.



IMPORTANT: Some models are not equipped with factory holes on pinch weld and will require drilling through holes on the pinch weld to attach the Support Bracket. Do not drill through pinch weld at this time, (Refer to Step 7).

- (1) M8X1.25-30 Hex Bolt
- (2) M8 Large Flat Washers
- (1) M8X1.25 Nylon Lock Nut

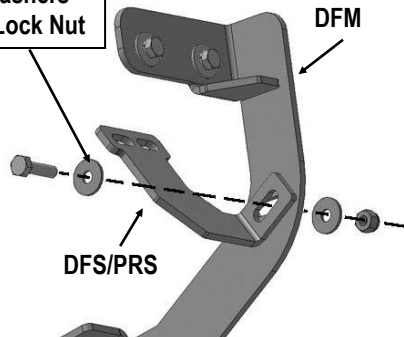

(Fig 9) Attach Driver Front Support Bracket to the Driver Front Mounting Bracket

- (2) M6X1-25 Hex Bolts
- (4) M6 Large Flat Washers
- (2) M6X1 Nylon Lock Nuts

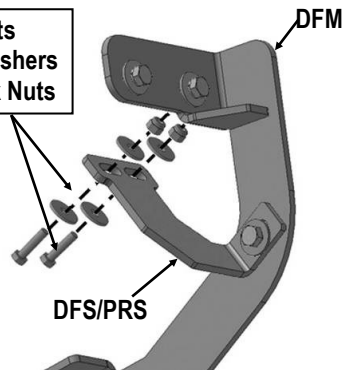

(Fig 10) Attach Support Bracket to the Back of Pinch Weld (Some Models May Require to Drill Holes on Pinch Weld)

STEP 4

Move to the Driver Side Rear Mounting location, (Fig 11). Repeat **Steps 1-3** to install the Driver Rear Mounting Bracket (DRM) and Driver Rear Support Bracket (PFS/DRS), (Fig 12). Do not tighten hardware at this time.



(Fig 11) Driver Side Rear Mounting Location

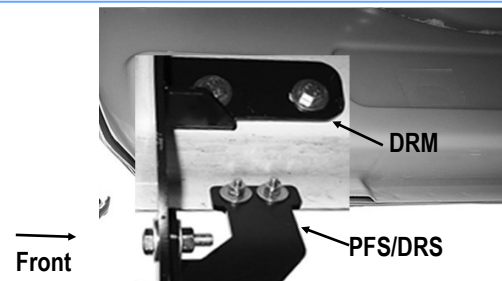

(Fig 12) Driver Side Rear Brackets Installed

STEP 5

Select the Driver Rear Bar Bracket (DRB), bolt to the Driver Rear Mounting Bracket (DRM) with (2) M10X1.5-30 Hex Bolts, (2) M10 Lock Washers, (4) M10 Flat Washers and (2) M10X1.5 Hex Nuts. (Fig 13). Do not fully tighten hardware at this time.

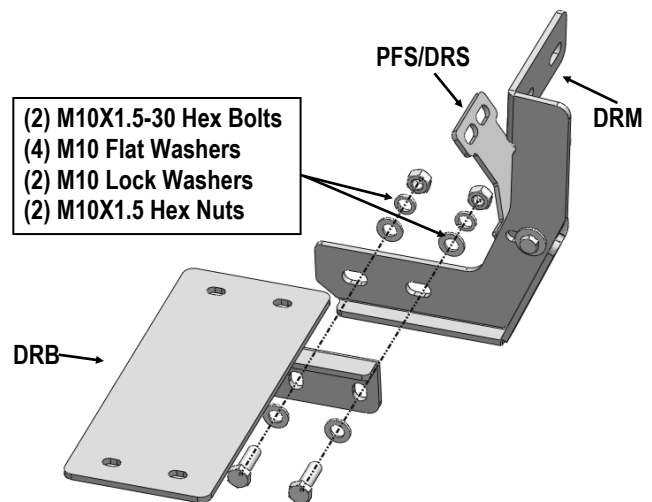

(Fig 13) Driver Side Rear Bar Bracket Assembly



STEP 6

Once all (2) Driver side mounting brackets are installed, then proceed to the Step Bar installation. (Figs 14&15)

- (1) Select (1) Slider and (2) M8X1.25-35mm Carriage Bolts;
- (2) Install (2) M8X1.25-35mm Carriage Bolts in (1) Slider.
- (3) Slide the Slider (with carriage bolts) to the **Step Bar**.
- (4) Repeat to install the other (1) slider to the step bar.
- (5) Attach the Step Bar (with the Sliders) onto the installed mounting brackets. Position the Sliders to the installed brackets. Secure the Step Bar to the installed Brackets by using (4) M8 Large Flat Washers and (4) M8 Nylon Lock Nuts and (2) Sliders, (Fig 15). Do not fully tighten hardware at this time.

Note: The Sliders are packed with the Step Bars.

Models with factory holes on pinch weld: Repeat **Steps 1-6** for the other side Step Bar installation. **The installation is completed.**

STEP 7

Models requiring drilling for driver side Support Brackets:

- a. Make sure the Step Bar is level to the vehicle. Adjust and tighten all mounting hardware.
- b. Line up the slots on the Support Brackets with the back of the pinch weld. Mark the location of the slots onto the pinch weld.
- c. Drill (2) 1/4" holes through the pinch weld for each Support Bracket. **IMPORTANT:** Do not drill too close to the bottom edge of the pinch weld. Adjust the Brackets as necessary to move the slots up the body panel away from the edge. Drill the holes toward the outside of the marked slots.
- d. Attach each Support Brackets to the pinch weld with (2) M6X1-25 Hex Bolts, (4) M6 Large Flat Washers and (2) M6X1 Nylon Lock Nuts, (Fig 12). Check for level then fully tighten all hardware.

Repeat **Steps 1-7** for the other side Step Bar installation. **The installation is completed!!!**

Attention

Do periodic inspections to the installation to make sure that all hardware is secure and tight.
In order to protect your bars/boards, please use mild soap/non-abrasive products for cleaning only.

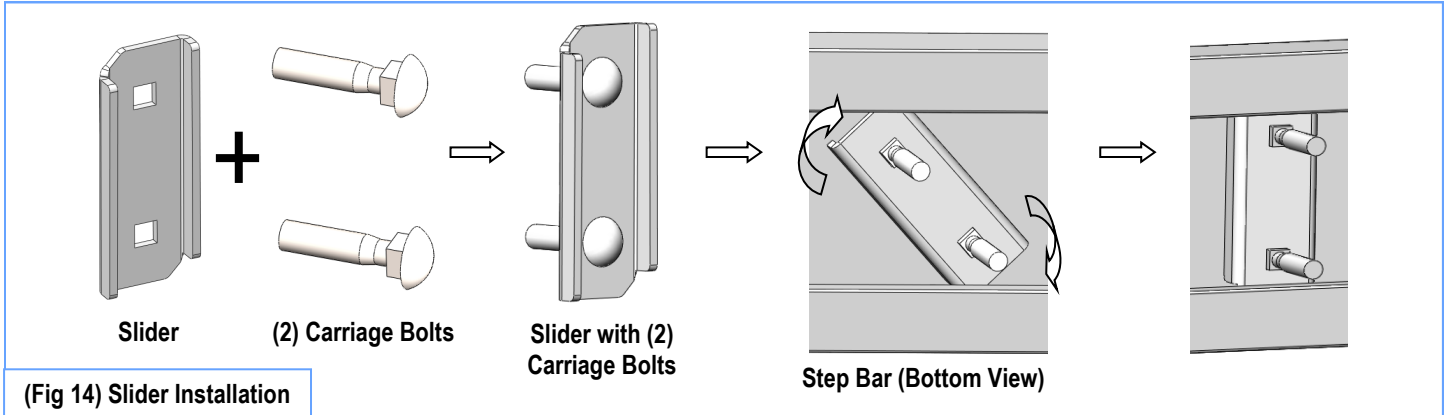

(Fig 14) Slider Installation

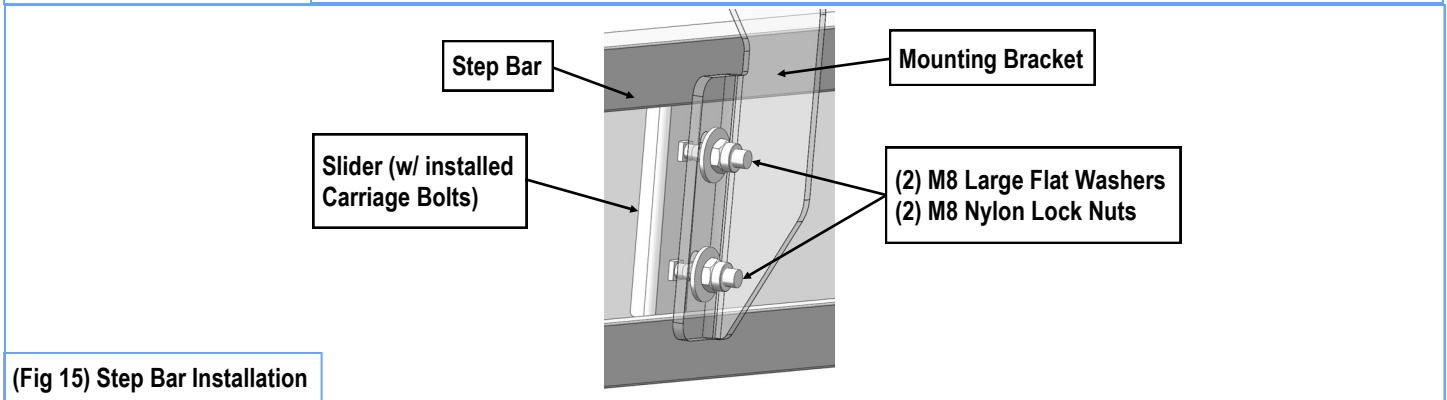

(Fig 15) Step Bar Installation