

iBoard®



Scan for
Installation Video

iBoard® by APS

PART#: IB-R071/R195

READ INSTRUCTIONS CAREFULLY BEFORE STARTING INSTALLATION. REMOVE CONTENTS FROM BOX AND VERIFY ALL PARTS ARE PRESENT. ASSISTANCE IS RECOMMENDED.

*ROCKER PANEL MOUNT
*NO DRILLING REQUIRED/CUTTING MAYBE REQUIRED

Fastener Size	Tightening Torque (ft-lbs)	Required
6mm	6-7	√
8mm	16-18	√
10mm	31-32	X
12mm	56-58	X
14mm	92-94	X

Driver

Front

Passenger

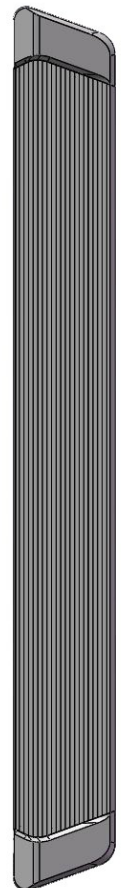
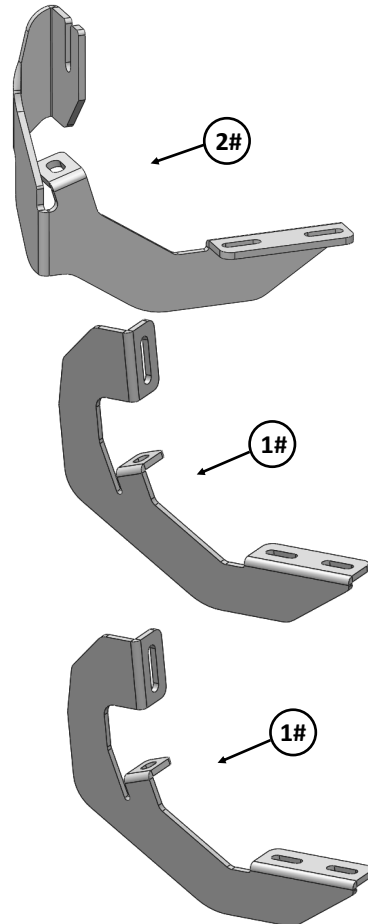
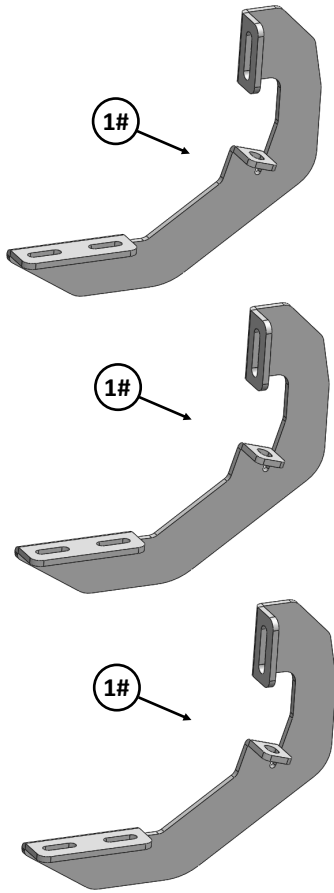
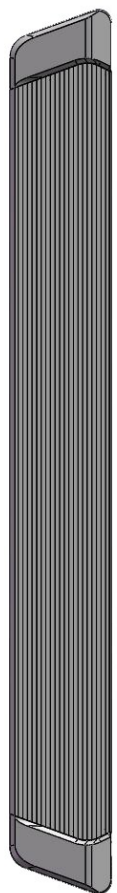

Customer Support: info@iboardauto.com



Hardware Package A (For Bracket Installation)

Item	QTY	Description	Item	QTY	Description
1#	5	Driver Front / Center / Rear / Passenger Center / Rear Mounting Brackets	4#	12	M8 Large Flat Washers
2#	1	Passenger Front Mounting Bracket	5#	12	M8 Lock Washers
3#	12	M8X1.25-25mm Hex Bolts	6#	12	M8 Clip Nuts

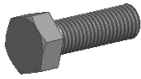

3#



4 #



5 #

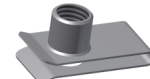

6 #

Hardware Package B (For Step Bar Installation)

Item	QTY	Description	Item	QTY	Description
1#	12	M6X1-20mm Square Head Bolts	3#	12	M6 Nylon Lock Nuts
2#	12	M6 Large Flat Washers			

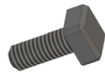

1#



2#



3#



STEP 1

Start the installation under the driver side of the vehicle. Locate the 3 tabs along the bottom edge of the body, (pinch weld). Mounting Brackets will be bolted to the 1st, 2nd and 4th mounting tabs, (Fig 1). Directly above each tab is a top mounting location on the side of the body panel. Hold a Bracket up in place to help determine the mounting holes to be used on the body.

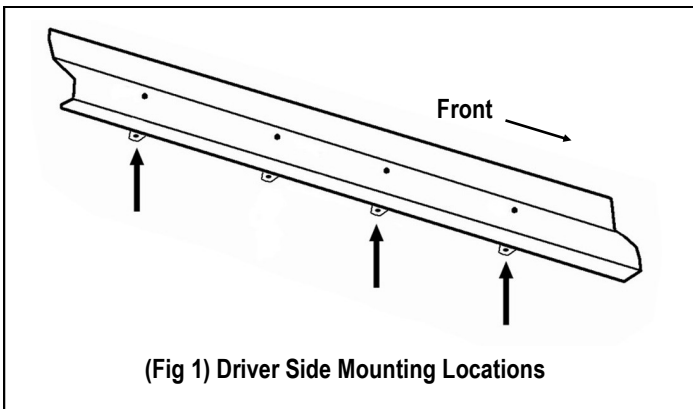

(Fig 1) Driver Side Mounting Locations

STEP 2

Determine the correct procedure for your model year and each Bracket location.

Lower mounting location (on the edge of the pinch weld):

***Flat tab on pinch weld with factory installed weld nut:**

Thread M8 Hex Bolt into weld nut from to clear up the paint from threads, (Fig 2).

***Flat tab on pinch weld with hole:**

Select (1) M8 Clip Nut. Slide the M8 Clip Nut over the tab with the nut facing up behind the tab, (Figs 3—5). Line up threaded nut with hole in tab. Repeat for each mounting location.

Upper mounting location (on the back of the body panel):

***Models with factory installed threaded insert in body panel:**

Thread M8 Hex Bolt into threaded insert to clear paint as required, (Fig 2 & 3).

***Large and small hole on back side of body panel:**

Remove the rubber plug from the larger hole, (Fig 4). Select (1) M8 Clip Nut. Slide the M8 Clip Nut into the larger hole. Line up the threaded nut with the smaller hole, (Fig 5).

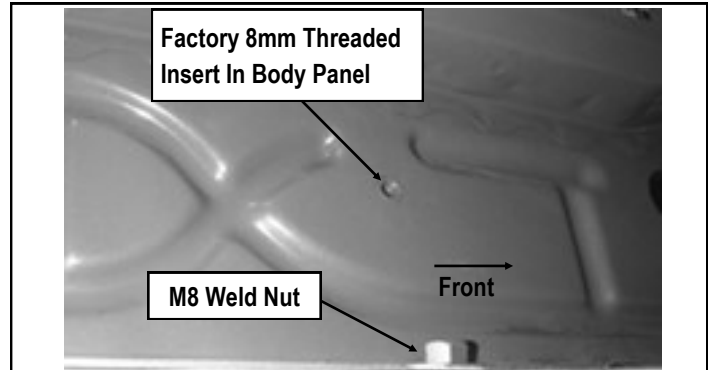

(Fig 2) Driver Front Mounting Bracket Location

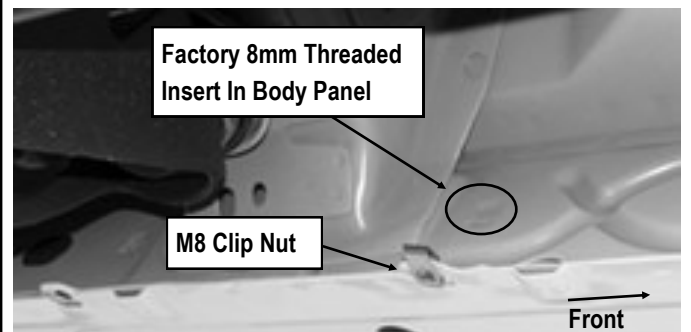

(Fig 3) Driver Side Center Mounting Location

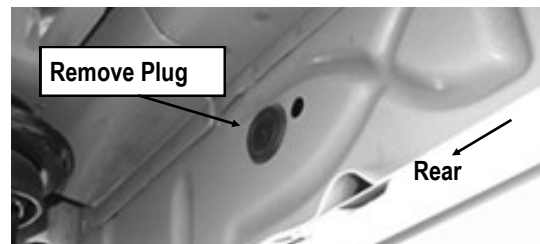

(Fig 4) Driver Side Center Mounting Location
(With Rubber Plug on Mounting Hole)

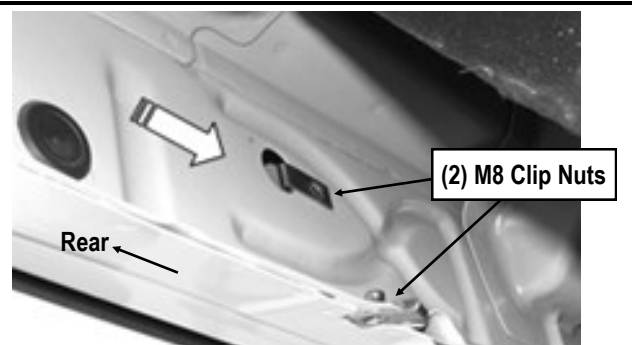

(Fig 5) Driver Side Rear Mounting Location



STEP 3

Select (1) Driver Front Mounting Bracket, bolt the Mounting Bracket to the installed M8 Clip Nuts and/or the factory threaded holes on Driver Side Front Mounting Location with (2) M8 X1.25-25mm Hex Bolts, (2) M8 Lock Washers and (2) M8 Large Flat Washers, (Fig 6). Snug but do not fully tighten the hardware.

- (2) M8x1.25-25mm Hex Bolts
- (2) M8 Lock Washers
- (2) M8 Large Flat Washers



(Fig 6) Driver Front Mounting Bracket Installed

STEP 4

Repeat **Steps 1-3** to install the driver side center/rear Bracket.

STEP 5

Once all (3) brackets have been installed. Select a Running Board. Slip (3) M6X1-20mm Square Head Bolts into each bottom channel (Fig 7). Carefully position the Running Board onto the (3) Mounting Brackets. Attach the Running Board to each Mounting Bracket with (2) M6X1-20mm Square Head Bolts, (2) M6 Large Flat Washers and (2) M6 Nylon Lock Nuts (Fig 8). Do not fully tighten at this time.

IMPORTANT: Do not slide the Running Board on the Brackets or the bottom surface of the board will be damaged.

- M6X1-20mm Square Head Bolts

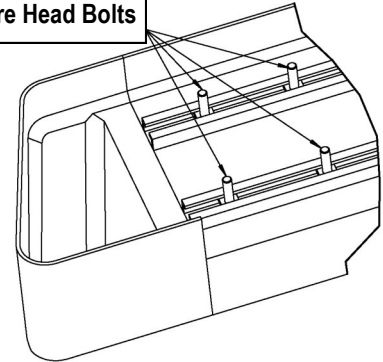

(Fig 7) Slip M6X1-20mm Square Head Bolts Into The Bottom Channels

- (2) M6X1-20mm Square Head Bolts
- (2) M6 Large Flat Washers
- (2) M6 Nylon Lock Nuts

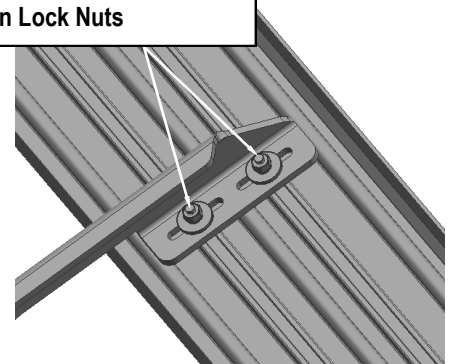

(Fig 8) Running Board Installed Onto Mounting Bracket

STEP 6

Level and adjust the Running Board and fully tighten all hardware.

Important: Please follow the recommended Tightening Torques shown in the table on page 1. Don't over tighten, or the nuts/bolts will be damaged.



STEP 7

Move to the passenger side of the vehicle. On the passenger side, determine if the vehicle is equipped with a plastic diesel exhaust fluid (DEF) tank, (Fig 9 & 10).

Models without DEF tank, skip to Step 8.

Models with DEF tank: The tank sits close to the side of the body. With specialized tools, the Passenger Front Mounting Bracket can be installed but room is limited. It may be easier to drop the tank down to access the inner side of the body panel for bracket installation. Tank will not need to be removed, only dropped down for access to mounting location.

IMPORTANT: If tank is full, it will be very heavy and assistance is highly recommended to avoid injury or damage the vehicle or the tank. It is recommended that installation is performed when the DEF tank is low on fluid before dropping the tank.

- a. **For 07-16 Models:** with plastic lower tray under the tank, remove the (3) hex bolts attaching the tray to the frame, (Fig 9), and remove the tray.
- b. **For 2017-Up 2500/3500 models:** Remove the (4) hex bolts attaching the plastic cover to DEF tank, (Fig 10A) and remove the plastic cover, (Fig 10B).
- c. Release the tank filler hose. Release the plug for the sending unit on the top of the tank.
- d. Support the tank with a floor jack. Place a smooth flat surface, (wooden block for example), between the floor jack and the tank to avoid damaging the plastic tank. Do not push up on the tank; only support the weight of the tank with the jack.
- e. Remove the (2) bolts securing the tank straps to the vehicle, (Fig 11). Tilt the straps to release from the brackets. Slowly lower the tank until the top of the tank is almost visible. Use blocks or stands to support the tank while installing the front Brackets.
- f. Proceed to **Step 8**.

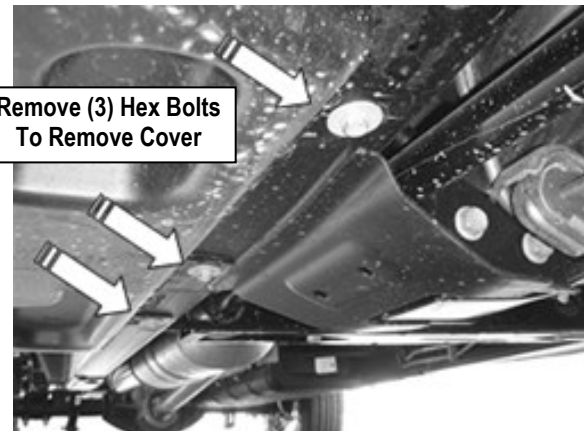

(Fig 9) 07-16 Passenger Side Front Pictured With DEF Tank Cover



(Fig 10A) 2017-Up 2500/3500 Models Passenger Side Pictured (With DEF Plastic Tank Cover)

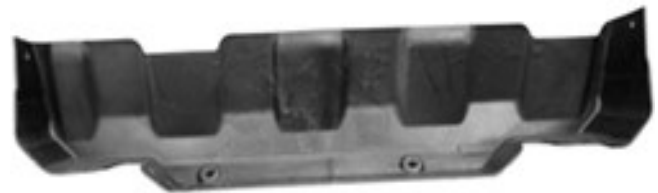

(Fig 10B) 2017 Passenger Side DEF Cover Removed

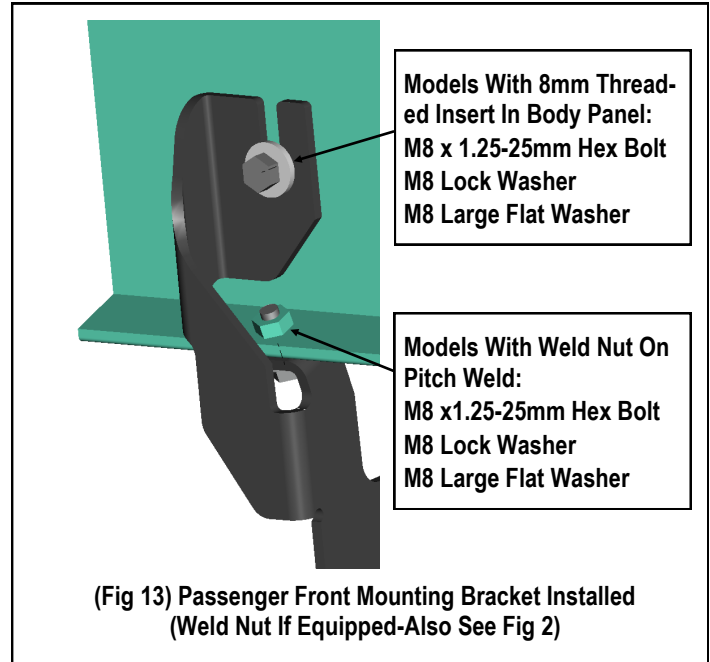

STEP 8

Locate the first tab on the edge of the pinch weld, attach the Passenger Front Mounting Bracket to the pinch weld and top body panel (Fig 12 & 13):

- Models with flat tab and hole:** see Fig 12. Leave loose at this time.
- Models with weld-nut:** see Fig 13. Leave loose at this time.

STEP 9

Repeat **Steps 2—4** for the (2) remaining passenger side mounting brackets installations.

2017-up 2500/3500 DEF tank models: Locate the 2nd tab bracket location along the bottom edge of the body, (pinch weld), (Fig 14). Hold the DEF cover in place and mark the 2nd Bracket location onto the cover, (Fig 15). Use a sharp knife or hacksaw blade to carefully cut a slot in the plastic cover to clear the 2nd Bracket, (Fig 16). Remove as little plastic as possible.

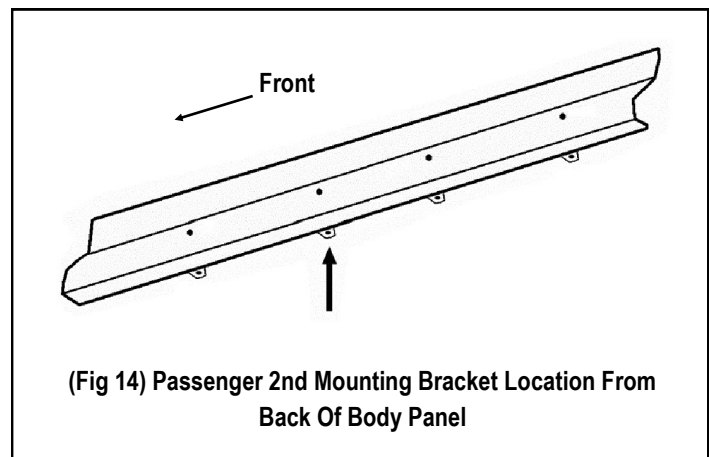
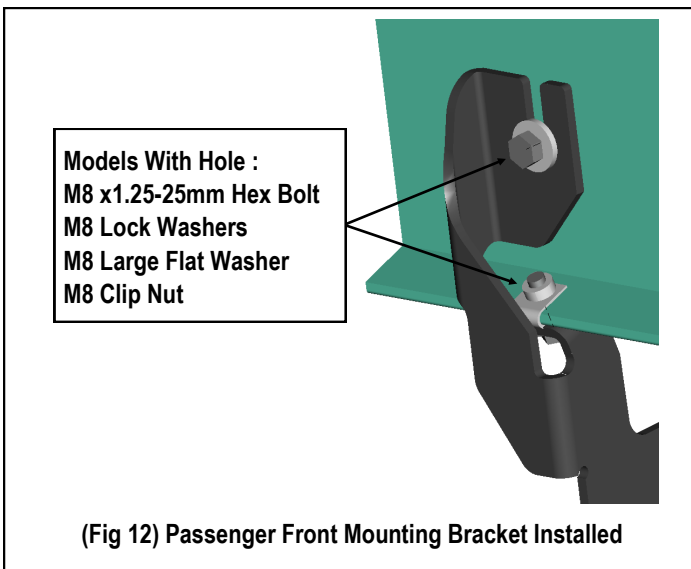

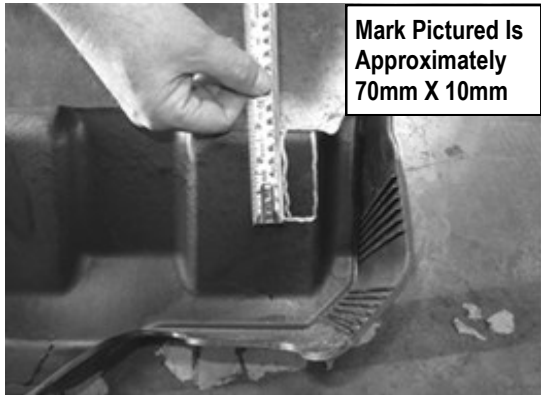

(Fig 15) 2017-Up Passenger Side DEF Cover
Marked For Trimming

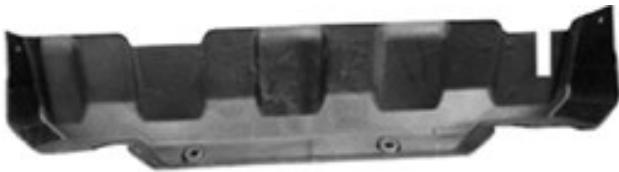

(Fig 16) 17-Up Passenger Side DEF Cut For Example Only

STEP 10

Repeat **Steps 5 & 6** to install the passenger side Running Board installation.

STEP 11

Once the Running Board are installed and all hardware fully tightened, reinstall the DEF tank and cover, if equipped, as described in **Step 7**.

The installation is completed .

Attention

Do periodic inspections to the installation to make sure that all hardware is secure and tight.

In order to protect your bars/boards, please use mild soap/non-abrasive products for cleaning only.