

iBoard®

iBoard® by APS

PART#: IB-R020

READ INSTRUCTIONS CAREFULLY BEFORE STARTING INSTALLATION. REMOVE CONTENTS FROM BOX AND VERIFY ALL PARTS ARE PRESENT. ASSISTANCE IS RECOMMENDED.

*ROCKER PANEL MOUNT
*NO DRILLING REQUIRED

| Fastener Size | Tightening Torque (ft-lbs) | Required |
|---------------|----------------------------|----------|
| 6mm | 6-7 | √ |
| 8mm | 16-18 | √ |
| 10mm | 31-32 | X |
| 12mm | 56-58 | X |
| 14mm | 92-94 | X |

| Item | QTY | Description | Item | QTY | Description |
|------|-----|------------------------|------|-----|-----------------------------|
| 1# | 4 | Mounting Brackets | 6# | 4 | M10 Clip Nuts |
| 2# | 8 | M10X1.5-25mm Hex Bolts | 7# | 8 | M6X1-20mm Square Head Bolts |
| 3# | 12 | M10 Flat Washers | 8# | 8 | M6 Large Flat Washers |
| 4# | 4 | M10 Lock Washers | 9# | 8 | M6 Nylon Lock Nuts |
| 5# | 4 | M10 Hex Nuts | | | |

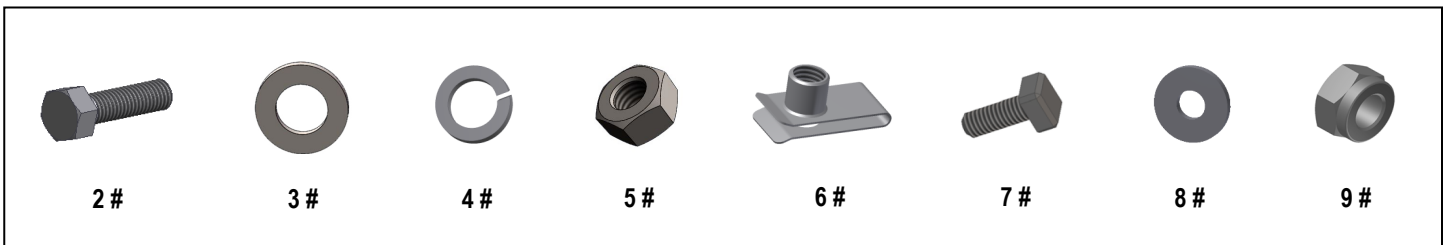

iBoard®

Driver

Front



Passenger

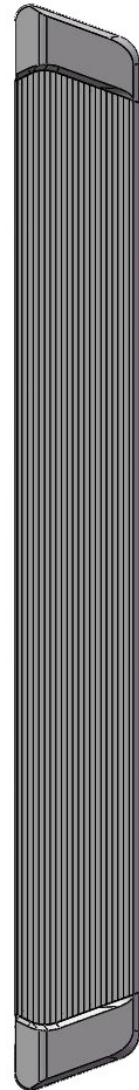
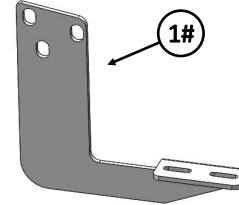
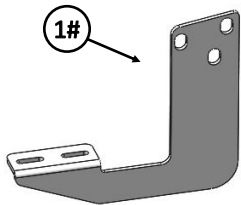
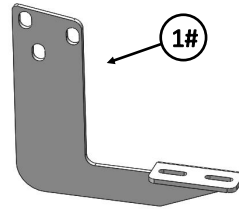
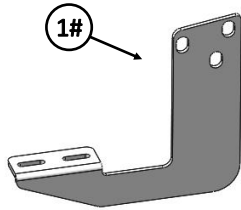
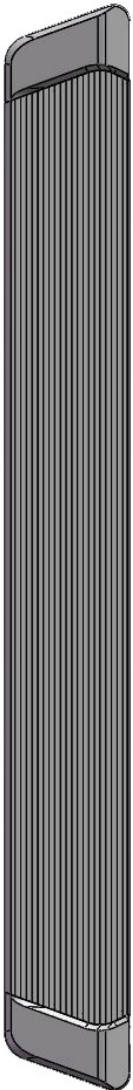

iBoard®

STEP 1

Starting from the Passenger side front of the vehicle. Insert M10 Clip Nuts in 2 of the mount brackets as shown, (Fig 1).

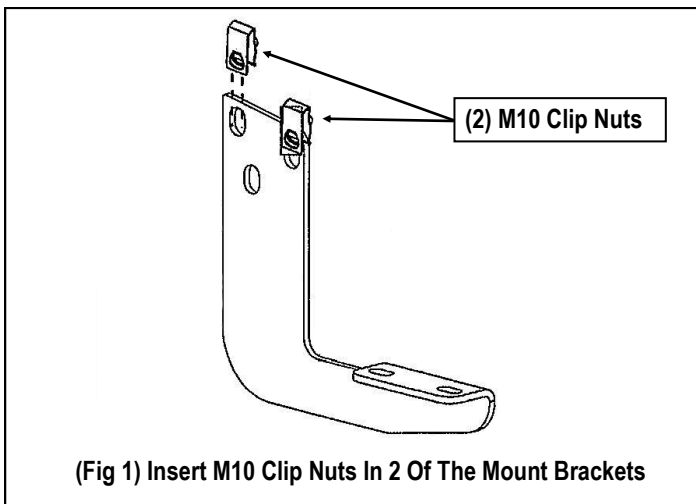

STEP 2

Attach (1) Mounting Bracket to the Passenger side front of the vehicle with (2) M10X1.5-25mm Hex Bolts and (2) M10 Flat Washers, (Figs 2 & 3). Do not fully tighten hardware at this time.

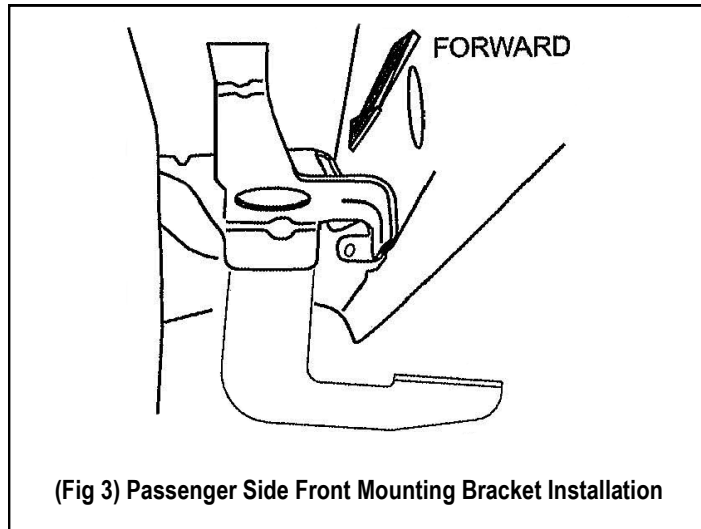
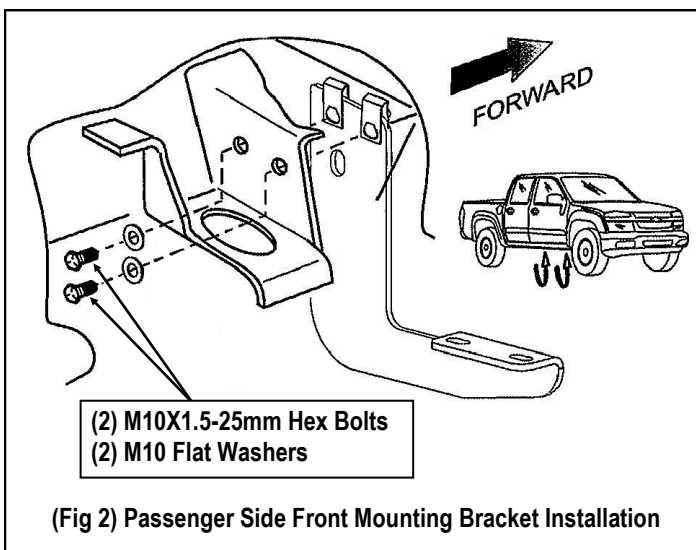

STEP 3

Move to the Passenger side rear of the vehicle, attach (1) Mounting Bracket with (2) M10X1.5-25mm Hex Bolts, (4) M10 Flat Washers, (2) M10 Lock Washers and (2) M10 Hex Nuts, (Fig 4). Do not fully tighten hardware at this time.

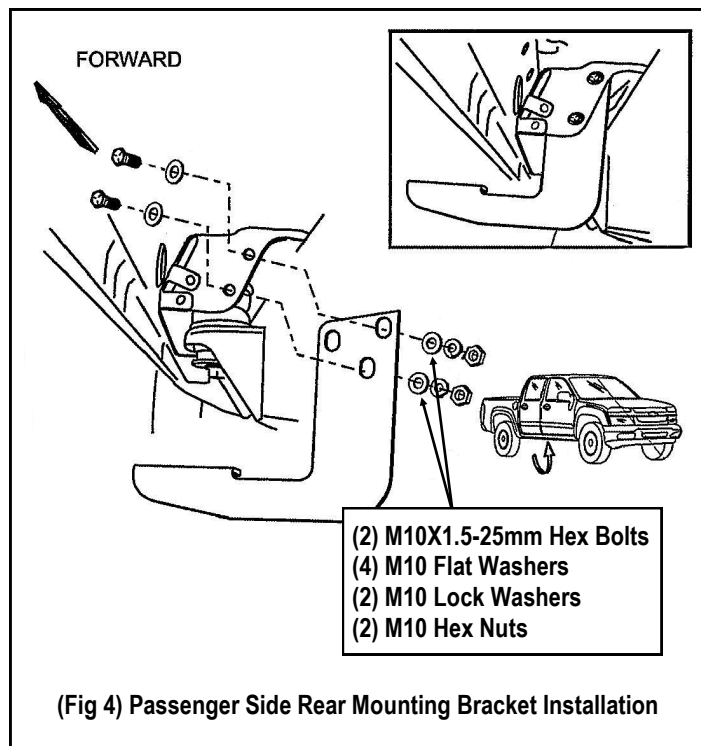

iBoard®

STEP 4

Select a Running Board. Slip (2) M6x1-20mm Square Head Bolts into each bottom channel (**Fig 5**). Carefully position the Running Board onto the (2) Mounting Brackets.

IMPORTANT: Do not slide the Running Board on the Brackets or the bottom surface of the board will be damaged. Attach the Running Board to Mounting Bracket with (2) M6x1-20mm Square Head Bolts, (2) M6 Large Flat Washers and (2) M6 Nylon Lock Nuts (**Fig 6**). Do not fully tighten at this time.

M6X1-20mm Square Head Bolts

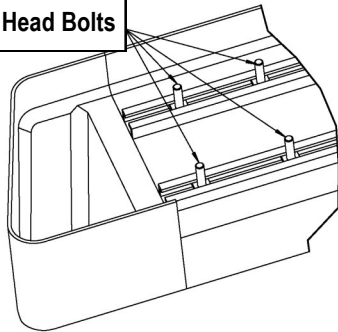

(Fig 5) Slip M6X1-20mm Square Head Bolts Into The Bottom Channels

(2) M6X1-20mm Square Head Bolts
(2) M6 Large Flat Washers
(2) M6 Nylon Lock Nuts

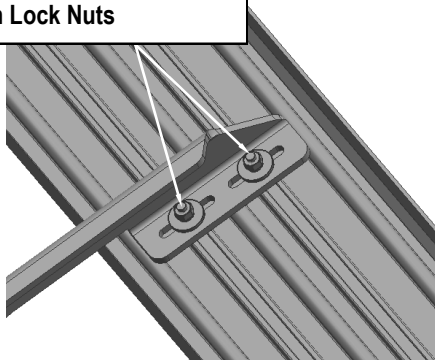

(Fig 6) Running Board Installed Onto Mounting Bracket

STEP 5

Level and adjust the Running Board and fully tighten all hardware.

Important: Please follow the recommended Tightening Torques shown in the table on page 1. Don't over tighten, or the nuts/bolts will be damaged.

STEP 6

Repeat **Steps 1-5** for the other side Running Board installation. The installation is completed.

Attention

Do periodic inspections to the installation to make sure that all hardware is secure and tight.

In order to protect your bars/boards, please use only mild soap/non-abrasive products for cleaning.