

iBoard®

iBoard® by APS

PART#: IB-R296

READ INSTRUCTIONS CAREFULLY BEFORE STARTING INSTALLATION. REMOVE CONTENTS FROM BOX AND VERIFY ALL PARTS ARE PRESENT. ASSISTANCE IS RECOMMENDED.

*ROCKER PANEL MOUNT
*NO DRILLING REQUIRED

Fastener Size	Tightening Torque (ft-lbs)	Required
6mm	6-7	√
8mm	16-18	√
10mm	31-32	X
12mm	56-58	X
14mm	92-94	X

Item	QTY	Description	Item	QTY	Description
1#	4	Mounting Brackets	5#	8	M6X1-20mm Square Head Bolts
2#	8	M8X1.25-30mm Hex Bolts	6#	8	M6 Large Flat Washers
3#	8	M8 Large Flat Washers	7#	8	M6 Nylon Lock Nuts
4#	8	M8 Lock Washers			

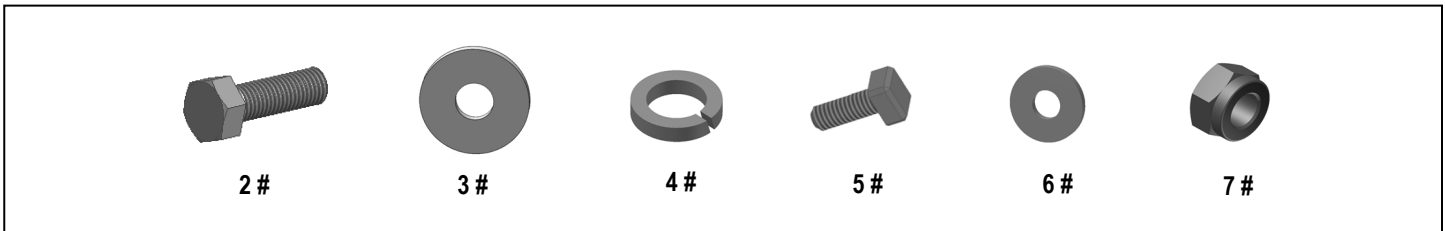

iBoard®

Driver

Front

Passenger

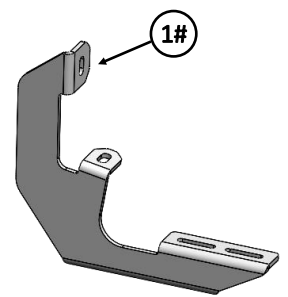
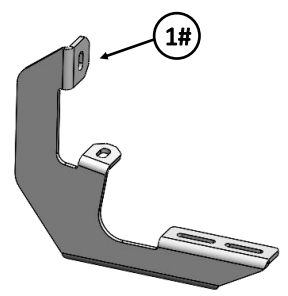
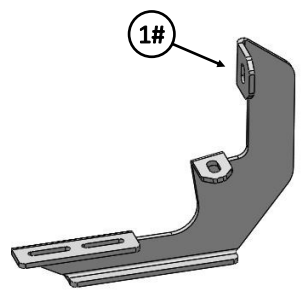
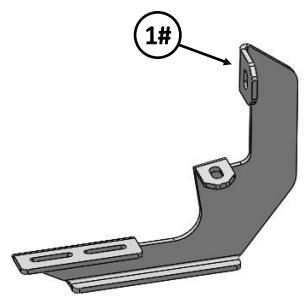
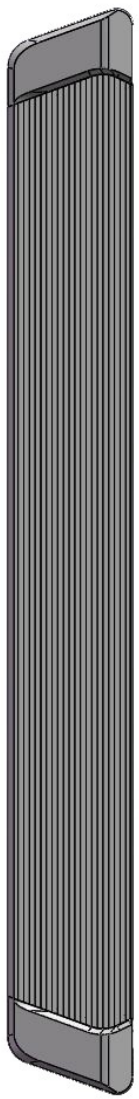

iBoard®

STEP 1

Start installation from the driver side front of the vehicle. Locate the plastic plugs along the bottom edge of the body, (**Fig 1**). Remove the plastic plugs from the front mounting location. Directly above each threaded insert is a top mounting location on the side of the body panel. Hold a Bracket up in place to help determine the correct mounting holes to use along the body.

NOTE: Thread an M8 Hex Bolt into the threaded inserts to clear paint as required.

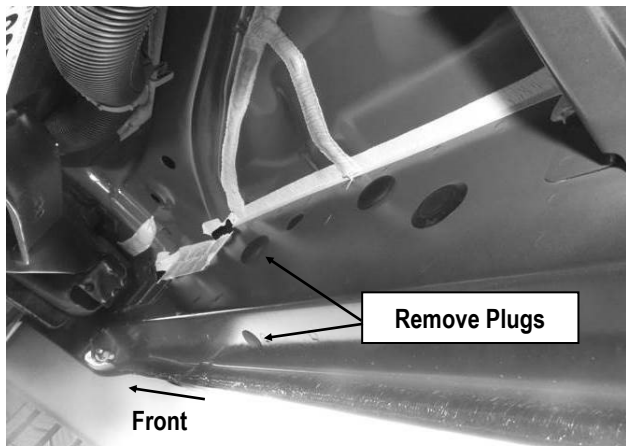

(Fig 1) Remove The Plastic Plugs

STEP 2

Start from the driver front mounting location, (**Fig 2**). Select (1) Mounting Bracket. Bolt the Mounting Bracket to the factory threaded holes with (2) M8X1.25-30mm Hex Bolts, (2) M8 Lock Washers and (2) M8 Large Flat Washers, (**Fig 3**). Do not fully tighten hardware at this time.

STEP 3

Continue move to the driver side rear of the vehicle, (**Fig 4**). Repeat **Steps 1 – 2** to install the remaining driver side Bracket in the rear location.

Note: (4) Mounting Brackets are universal.

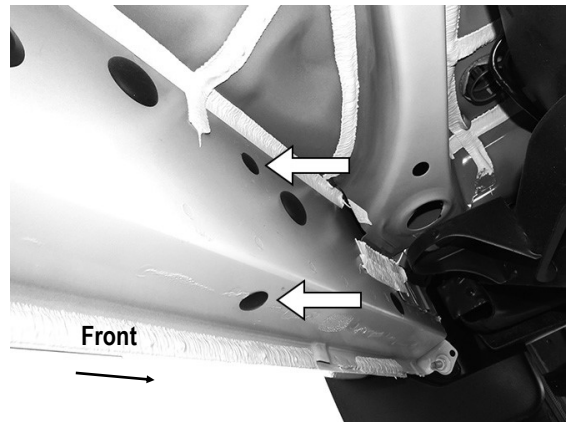

(Fig 2) Driver Front Mounting Location

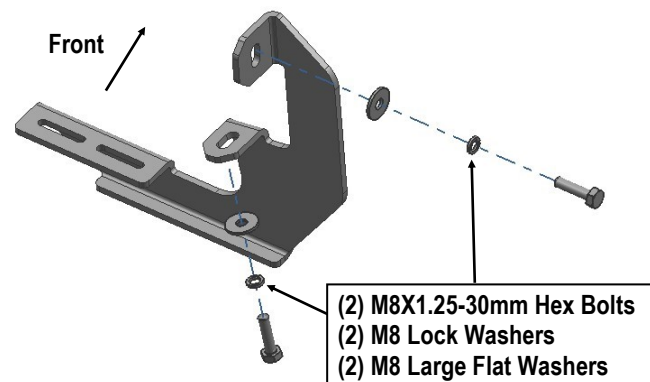

(Fig 3) Driver Side Front Mounting Bracket Installation

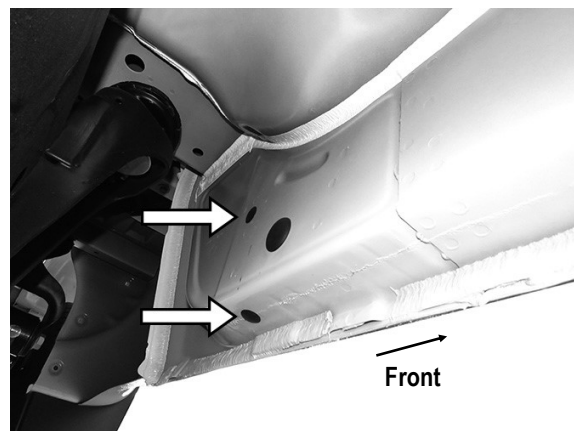

(Fig 4) Driver Side Rear Mounting Location

iBoard®

STEP 4

Select a Running Board. Slip (2) M6x1-20mm Square Head Bolts into each bottom channel (**Fig 5**). Carefully position the Running Board onto the (2) Mounting Brackets.

IMPORTANT: Do not slide the Running Board on the Brackets or the bottom surface of the board will be damaged. Attach the Running Board to each Mounting Bracket with (2) M6x1-20mm Square Head Bolts, (2) M6 Large Flat Washers and (2) M6 Nylon Lock Nuts (**Fig 6**). Do not fully tighten at this time.

M6X1-20mm Square Head Bolts

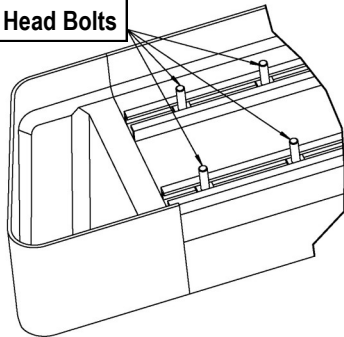

(Fig 5) Slip M6X1-20mm Square Head Bolts Into The Bottom Channels

(2) M6X1-20mm Square Head Bolts
(2) M6 Large Flat Washers
(2) M6 Nylon Lock Nuts

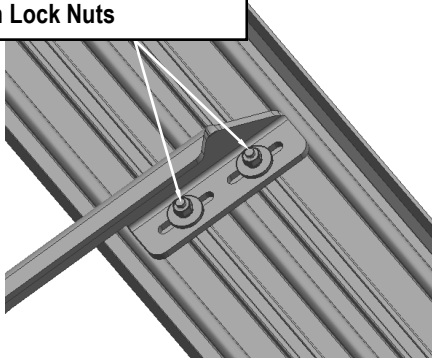

(Fig 6) Running Board Installed Onto Mounting Bracket

STEP 5

Level and adjust the Running Board and fully tighten all hardware.

Important: Please follow the recommended Tightening Torques shown in the table on page 1. Don't over tighten, or the nuts/bolts will be damaged.

STEP 6

Repeat **Steps 1-5** for the other side Running Board installation. The installation is completed.

Attention

Do periodic inspections to the installation to make sure that all hardware is secure and tight.

In order to protect your bars/boards, please use only mild soap/non-abrasive products for cleaning.