

# iBoard®

## iBoard® by APS

**PART#: IB-R197/R198**

**READ INSTRUCTIONS CAREFULLY BEFORE STARTING INSTALLATION. REMOVE CONTENTS FROM BOX AND VERIFY ALL PARTS ARE PRESENT. ASSISTANCE IS RECOMMENDED.**

**\*ROCKER PANEL MOUNT  
\*NO DRILLING REQUIRED**

Fastener Size	Tightening Torque (ft-lbs)	Required
6mm	6-7	√
8mm	16-18	√
10mm	31-32	X
12mm	56-58	X
14mm	92-94	X

Item	QTY	Description	Item	QTY	Description
1#	3	Driver Front/Center & Passenger Rear Mounting Brackets	6#	12	M8 Clip Nuts
2#	3	Passenger Front/Center & Driver Rear Mounting Brackets	7#	12	M6X1-20mm Square Head Bolts
3#	12	M8X1.25-30mm Hex Bolts	8#	12	M6 Large Flat Washers
4#	12	M8 Large Flat Washers	9#	12	M6X1 Nylon Lock Nuts
5#	12	M8 Lock Washers			

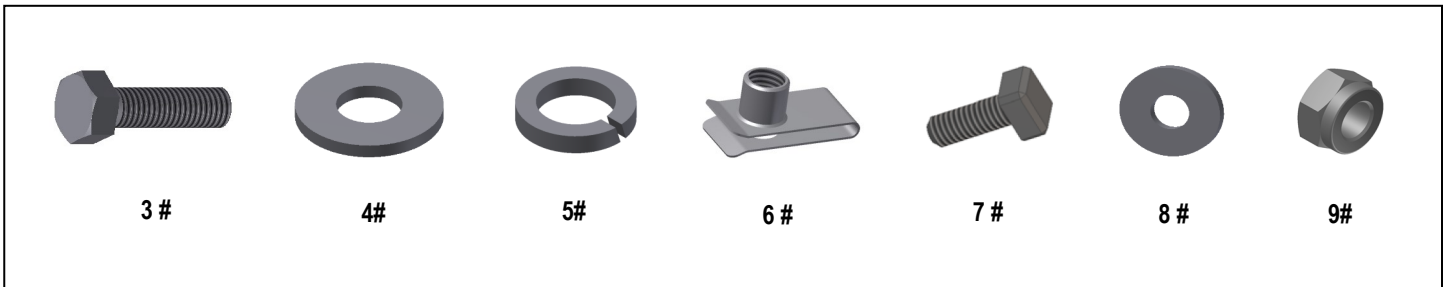

# iBoard®

Driver

Front



Passenger

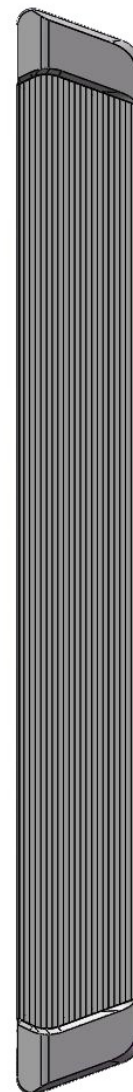
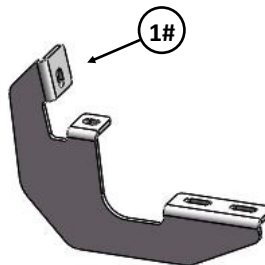
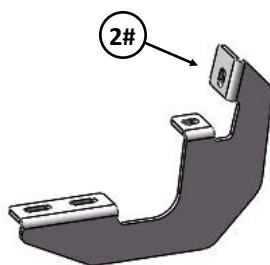
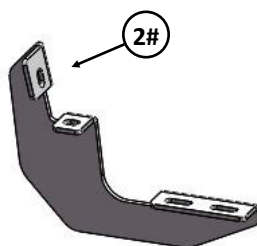
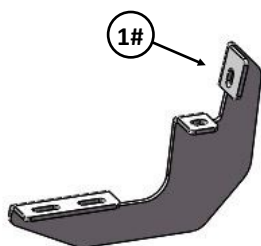
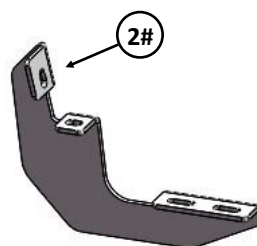
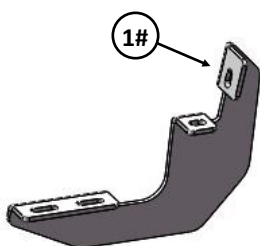

# iBoard®

## STEP 1

Start installation from the driver side front of the vehicle. If equipped, remove the plastic covers from the mounting locations on rocker panel, (**Fig 1**).

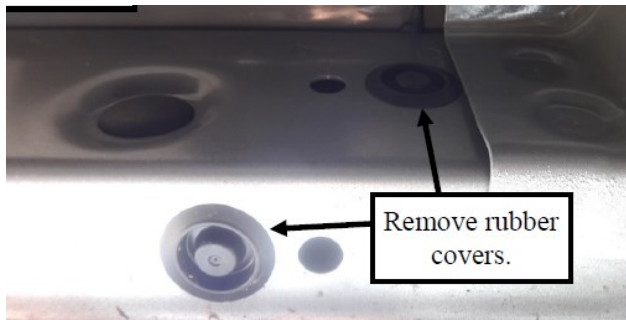

(Fig 1) Driver Side Front Mounting Location

## STEP 2

Install the M8 Clip Nuts in the holes where the plastic covers were removed, (**Fig 2**).

Select the Driver Front Mounting Bracket, attach the Bracket to the vehicle by using the included (2) M8x1.25-30mm Hex Bolts, (2) M8 Lock Washers and (2) M8 Large Flat Washers, (**Fig 3**). Do not fully tighten hardware at this time.

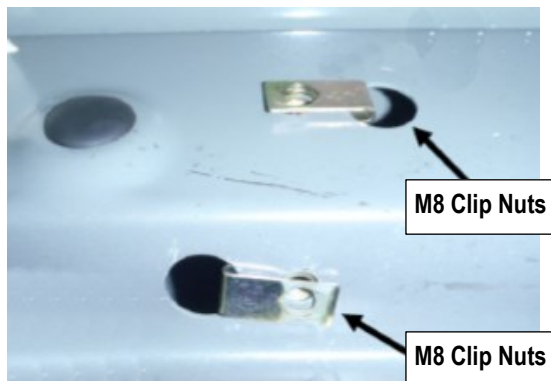

(Fig 2) Supplied M8 Clip Nuts Installed

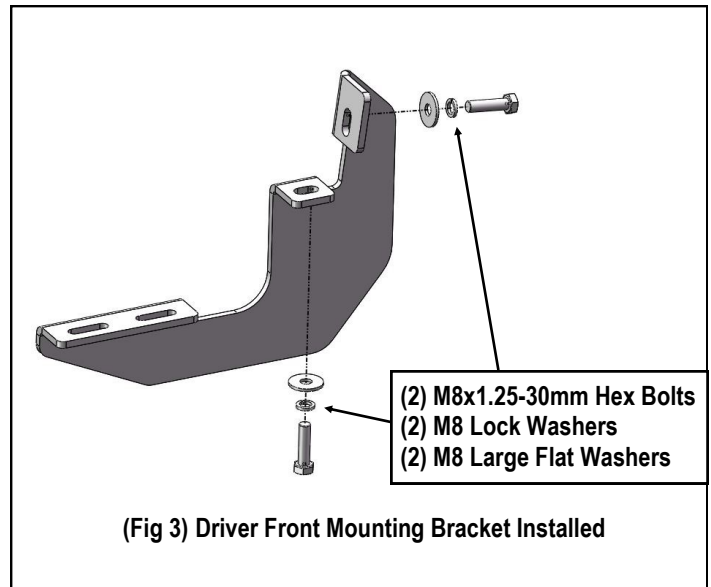

(Fig 3) Driver Front Mounting Bracket Installed

## STEP 3

Move to the driver side center and rear mounting locations, (**Fig 1**). Repeat **Steps 1 & 2** to install the Driver Center & Rear Mounting Brackets.

## STEP 4

Select a Running Board. Slip (3) M6x1-20mm Square Head Bolts into each bottom channel (**Fig 4**). Carefully position the Running Board onto the (3) Mounting Brackets.

**IMPORTANT:** Do not slide the Running Board on the Brackets or the bottom surface of the board will be damaged. Attach the Running Board to each Mounting Bracket with (2) M6x1-20mm Square Head Bolts, (2) M6 Large Flat Washers and (2) M6 X1 Nylon Lock Nuts (**Fig 5**). Do not fully tighten at this time.

# iBoard®

M6X1-20mm Square Head Bolts

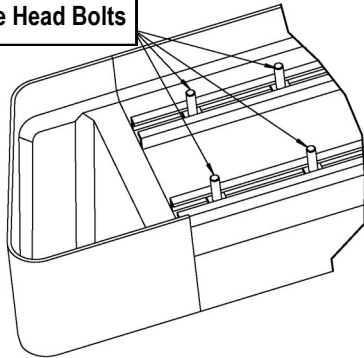

(Fig 4) Slip M6X1-20mm Square Head Bolts Into The Bottom Channels

(2) M6X1-20mm Square Head Bolts  
(2) M6 Large Flat Washers  
(2) M6X1 Nylon Lock Nuts

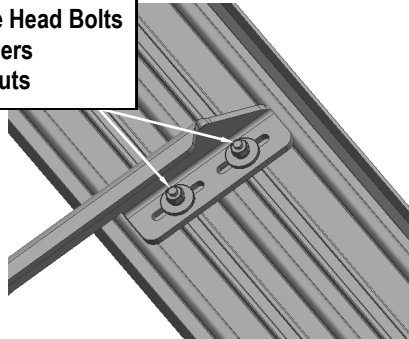

(Fig 5) Running Board Installed Onto Mounting Bracket

## STEP 5

Level and adjust the Running Board and fully tighten all hardware.

**Important:** Please follow the recommended Tightening Torques shown in the table on page 1. Don't over tighten, or the nuts/bolts will be damaged.

## STEP 6

Repeat **Steps 1-5** for the other side Running Board installation. The installation is completed .

### Attention

Do periodic inspections to the installation to make sure that all hardware is secure and tight.

In order to protect your bars/boards, please use only mild soap/non-abrasive products for cleaning.