

iBoard®

iBoard® by APS

PART#: IB-400A-B

READ INSTRUCTIONS CAREFULLY BEFORE STARTING INSTALLATION. REMOVE CONTENTS FROM BOX AND VERIFY ALL PARTS ARE PRESENT. ASSISTANCE IS RECOMMENDED.

*ROCKER PANEL MOUNT
*DRILLING IS REQUIRED

Fastener Size	Tightening Torque (ft-lbs)
6mm	6-7
8mm	16-18
10mm	31-32
12mm	56-58
14mm	92-94

PART LIST



Customer Support: info@iboardauto.com

iBoard®

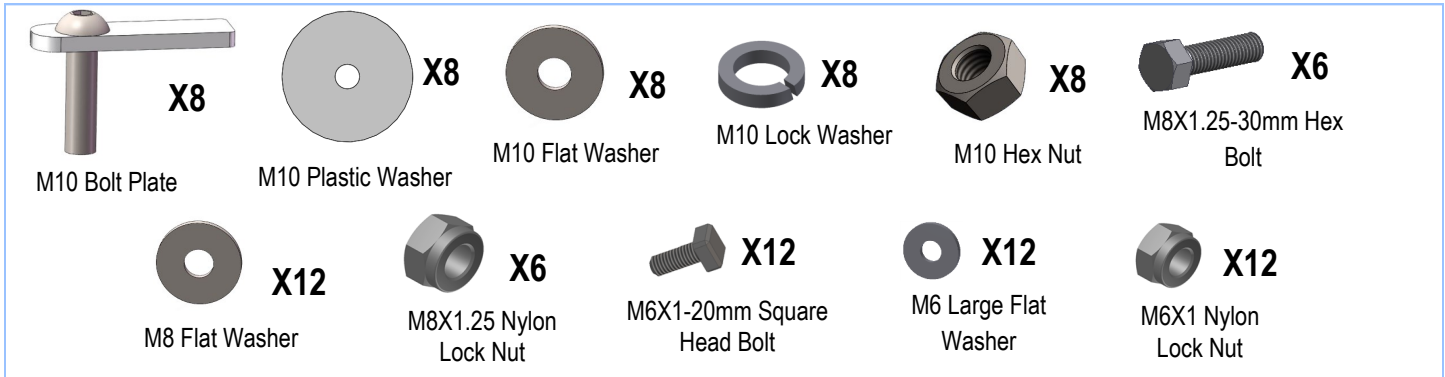

STEP 1

Starting installation from the driver side front of the vehicle. Locate and remove (1) rubber plug closest to the front tire opening, **(Fig 1)**. Select (1) M10 Bolt Plate and (1) M10 Plastic Washer. Partially thread the M10 Plastic Washer onto the M10 Bolt Plate. Insert the M10 Bolt Plate into the opening and thread the M10 Plastic Washer down tight, **(Fig 2)**.

NOTE: The M10 Plastic Washer is designed to help hold the M10 Bolt Plate in place during Bracket installation but is not required for installation.

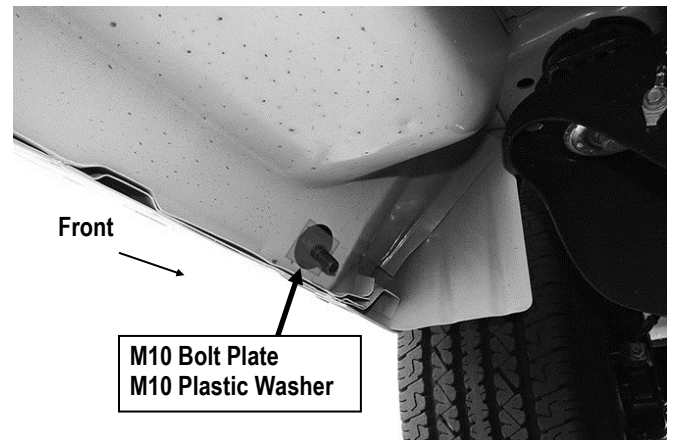

**(Fig 2) M10 Bolt Plate Installed
(Driver Side Front Mounting Location)**

STEP 2

Select the Driver Front Mounting Bracket (**DFM**). Attach the Bracket to the installed M10 Bolt Plate with (1) M10 Flat Washer, (1) M10 Lock Washer and (1) M10 Hex Nut, **(Fig 3 & 4)**. Do not fully tighten the hardware at this time.

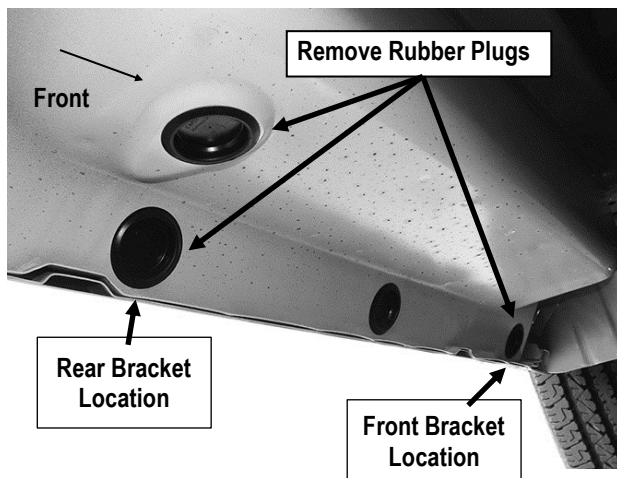

(Fig 1) Driver Side Mounting Bracket Locations

iBoard®

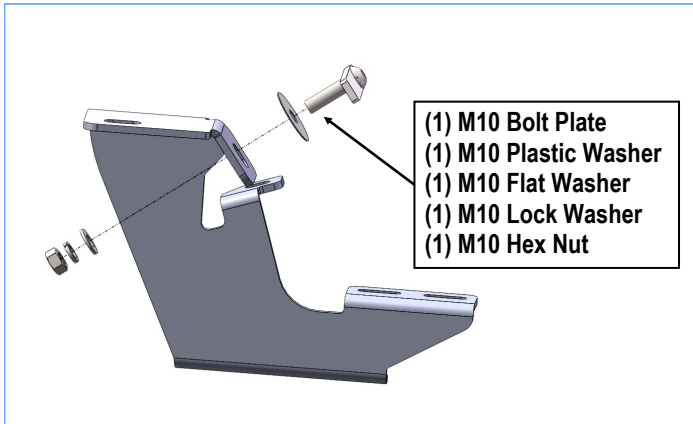

(Fig 3) Driver Front Mounting Bracket (DFM) Installation

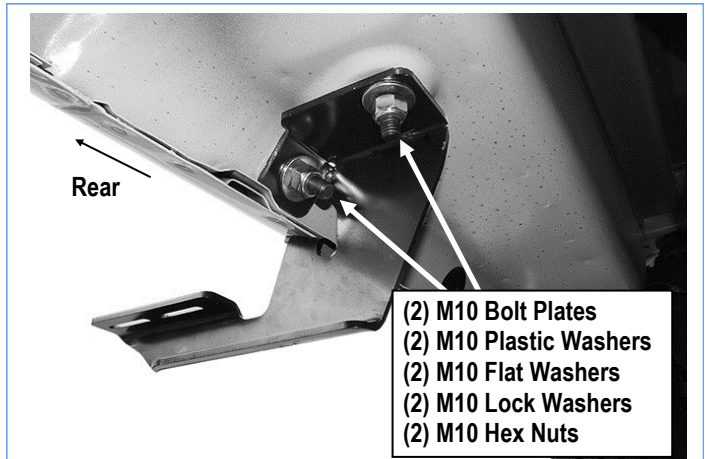

(Fig 5) Driver Rear Mounting Bracket (DRM) Installation

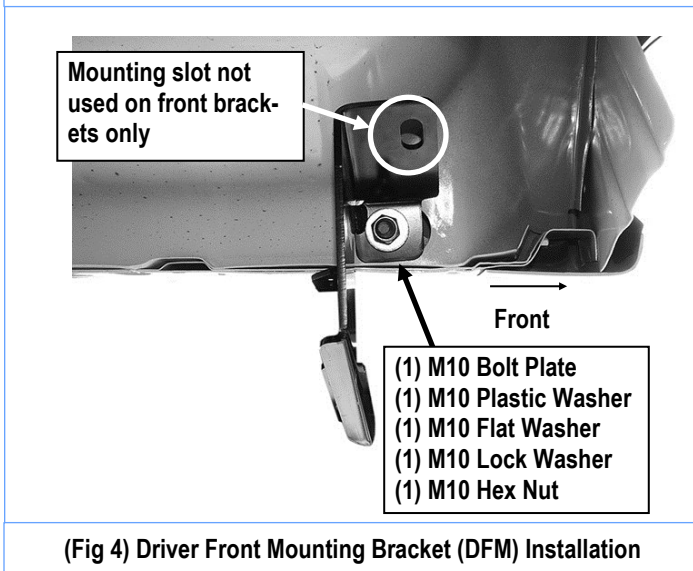

(Fig 4) Driver Front Mounting Bracket (DFM) Installation

STEP 4

Select the Driver Side Running Board. Slip (2) M6x1-20mm Square Head Bolts into each bottom channel (Fig 6). Carefully position the Running Board onto the (2) Mounting Brackets.

IMPORTANT: Do not slide the Running Board on the Brackets or the bottom surface of the board will be damaged. Attach the Running Board to Mounting Bracket with (4) M6x1-20mm Square Head Bolts, (4) M6 Large Flat Washers and (4) M6 X1 Nylon Lock Nuts (Fig 7). Do not fully tighten hardware at this time.

STEP 3

Move to the driver side rear of the vehicle, (Fig 1). Locate and remove the (2) rubber plugs. Insert (2) M10 Bolt Plates into the opening.

Repeat Steps 1 & 2 to attach the Driver Rear Mounting Bracket (DRM) to the (2) M10 Bolt Plates, (Fig 5). Do not fully tighten hardware at this time.



iBoard®

- (2) M6X1-20mm Square Head Bolts
- (2) M6 Large Flat Washers
- (2) M6X1 Nylon Lock Nuts

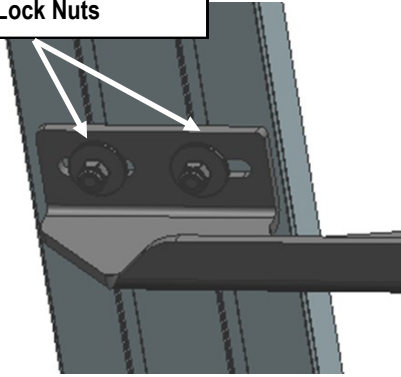

(Fig 7) Running Board Installed Onto Mounting Bracket (Example)

STEP 5

Level and adjust the Running Board and fully tighten all hardware.

Push the Mounting Brackets up tight against the bottom of the body. Use the mounting tab on each Bracket as a guide, mark the hole location and drill a 5/16" hole through the pinch weld on both Brackets, (Fig 8).

VERY IMPORTANT: Do not drill too close to the edge of the pinch weld, adjust Bracket position as required before drilling through pinch weld.

NOTE: If necessary, remove Running Board and Brackets to drill the holes through the pinch weld. Repeat **Steps 2—4** to reinstall Running Board.

IMPORTANT! Any cutting or drilling tool may break or shatter. Government regulations require safety glasses & equipment at all times when cutting or drilling.

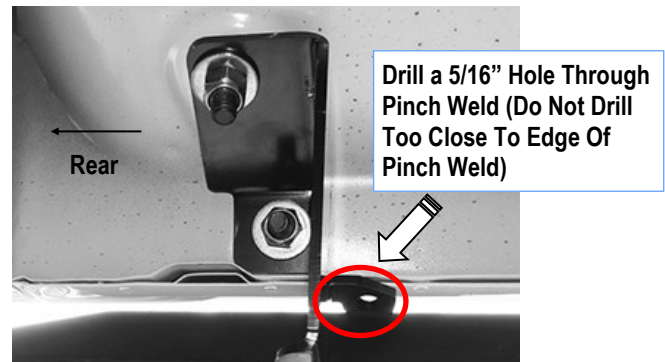

(Fig 8) Driver Hole On Driver Side Rear Mounting Location

STEP 6

Once both holes have been drilled on the pinch weld, attach the lower mounting tabs on the (2) Driver Side Mounting Brackets to the pinch weld with (2) M8X1.25-30mm Hex Bolts, (4) M8 Flat Washers and (2) M8 Nylon Lock Nuts, (Figs 9 & 10). Fully tighten hardware at this time.

- (1) M8X1.25-30mm Hex Bolt
- (2) M8 Flat Washers
- (1) M8 Nylon Lock Nut

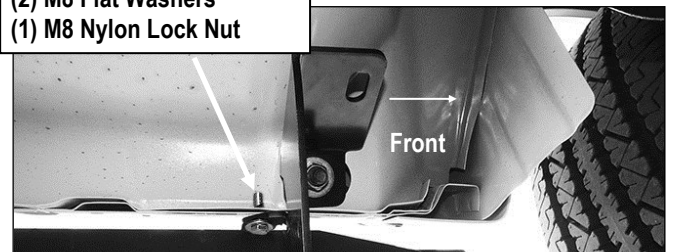

(Fig 9) Attach Driver Front Mounting Bracket To Pinch Weld

- (1) M8X1.25-30mm Hex Bolt
- (2) M8 Flat Washers
- (1) M8 Nylon Lock Nut

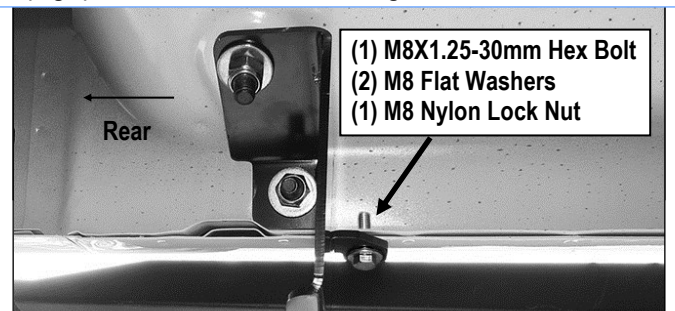

(Fig 10) Attach Driver Rear Mounting Bracket To Pinch Weld

iBoard®

STEP 7

Move to the passenger side front of the vehicle. Locate the rubber plug closest to the front tire opening, (Fig 11). Repeat **Steps 1 & 2** to install the Passenger Front Mounting Bracket (PFM), (Fig 12).

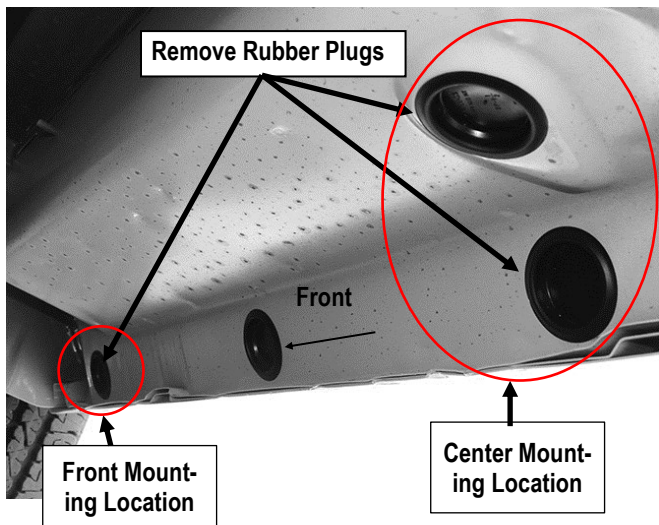

(Fig 11) Passenger Side Front & Center Mounting Locations

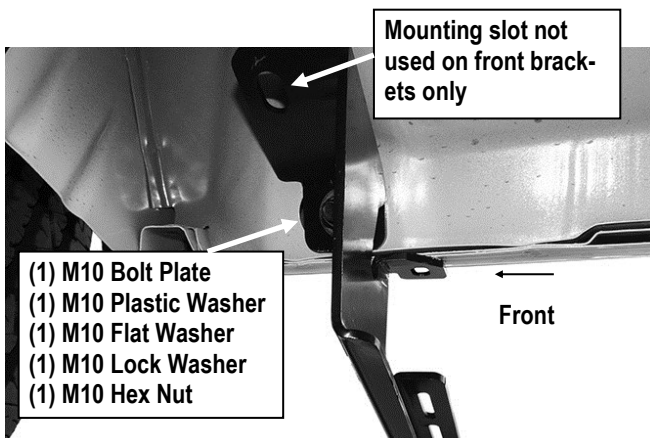

(Fig 12) Passenger Front Mounting Bracket (PFM) Installation

STEP 8

Move to the Passenger Side Center Mounting Location, (Fig 11). Repeat **Steps 1—3** to install the Passenger Center Mounting Bracket (PCM), (Fig 13).

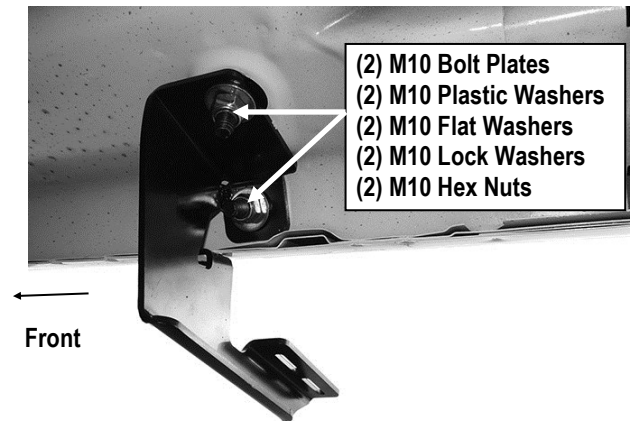

(Fig 13) Passenger Center Mounting Bracket (PCM) Installation

STEP 9

Move along the body to the (2) Passenger Side Rear Mounting Locations below the side door, (Fig 14). Locate and remove the rubber plugs next to the pinch weld.

Select (1) Passenger Rear Mounting Bracket (PRM). Repeat **Steps 1-2** to attach the (1) Passenger Rear Mounting Bracket (PRM) to the installed M10 Bolt Plate on 3rd location (Fig 15).

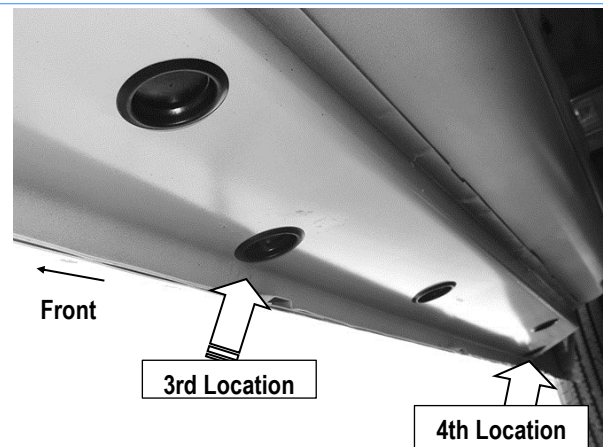

(Fig 14) Passenger Side Rear Mounting Locations

iBoard®

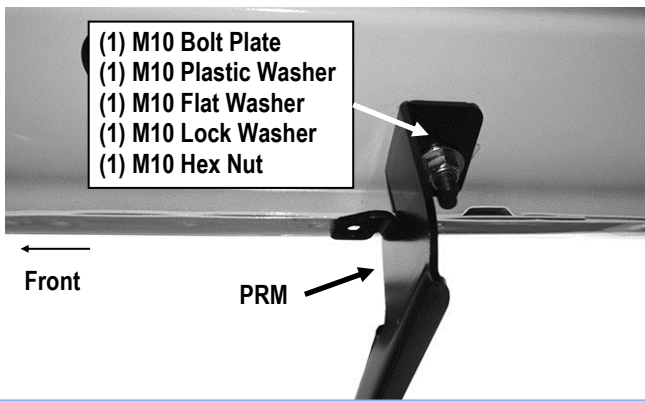

(Fig 15) Passenger Rear Mounting Bracket Installed on 3rd Mounting Location

STEP 10

Repeat **Steps 1-2** to attach the Passenger Rear Mounting Bracket (**PRM**) on the 4th location.

NOTE: (2) Passenger Rear Mounting Brackets are universal.

STEP 11

Select the Passenger Side Running Board. Slip (4) M6x1-20mm Square Head Bolts into each bottom channel (**Fig 6**). Repeat **Step 6** to attach the Running Board to (4) Mounting Brackets. Do not fully tighten hardware at this time.

STEP 12

Repeat **Steps 4—6** to drill and attach the (4) Mounting Brackets to the pinch weld, (**Figs 16—19**).

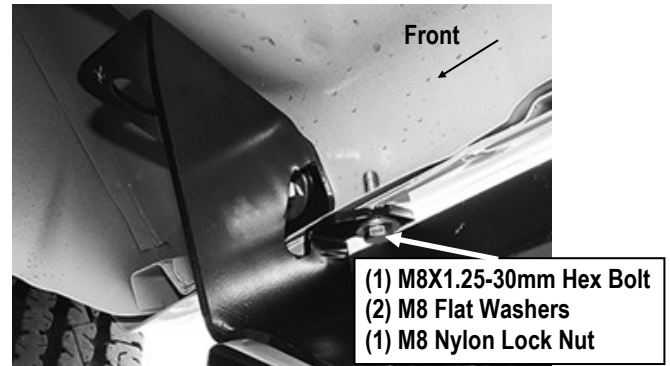

(Fig 16) Attach Passenger Front Mounting Bracket To Pinch Weld



(Fig 17) Attach Passenger Center Mounting Bracket To Pinch Weld



(Fig 18) Attach Passenger Rear Mounting Bracket (the 3rd one) to Pinch Weld



(Fig 19) Attach Passenger Rear Mounting Bracket (The Last One) to Pinch Weld

iBoard®

STEP 13

Level and adjust the Running Board and fully tighten all hardware.

Attention

Do periodic inspections to the installation to make sure that all hardware is secure and tight.

In order to protect your bars/boards, please use only mild soap/non-abrasive products for cleaning.



(Fig 20) Installation Completed