

iBoard®

iBoard® by APS

PART#: IB-333A-B

READ INSTRUCTIONS CAREFULLY BEFORE STARTING INSTALLATION. REMOVE CONTENTS FROM BOX AND VERIFY ALL PARTS ARE PRESENT. ASSISTANCE IS RECOMMENDED.

*ROCKER PANEL MOUNT

*DRILLING / HOLE ENLARGE MAY BE REQUIRED

| Fastener Size | Tightening Torque (ft-lbs) |
|---------------|----------------------------|
| 6mm | 6-7 |
| 8mm | 16-18 |
| 10mm | 31-32 |
| 12mm | 56-58 |
| 14mm | 92-94 |

PART LIST

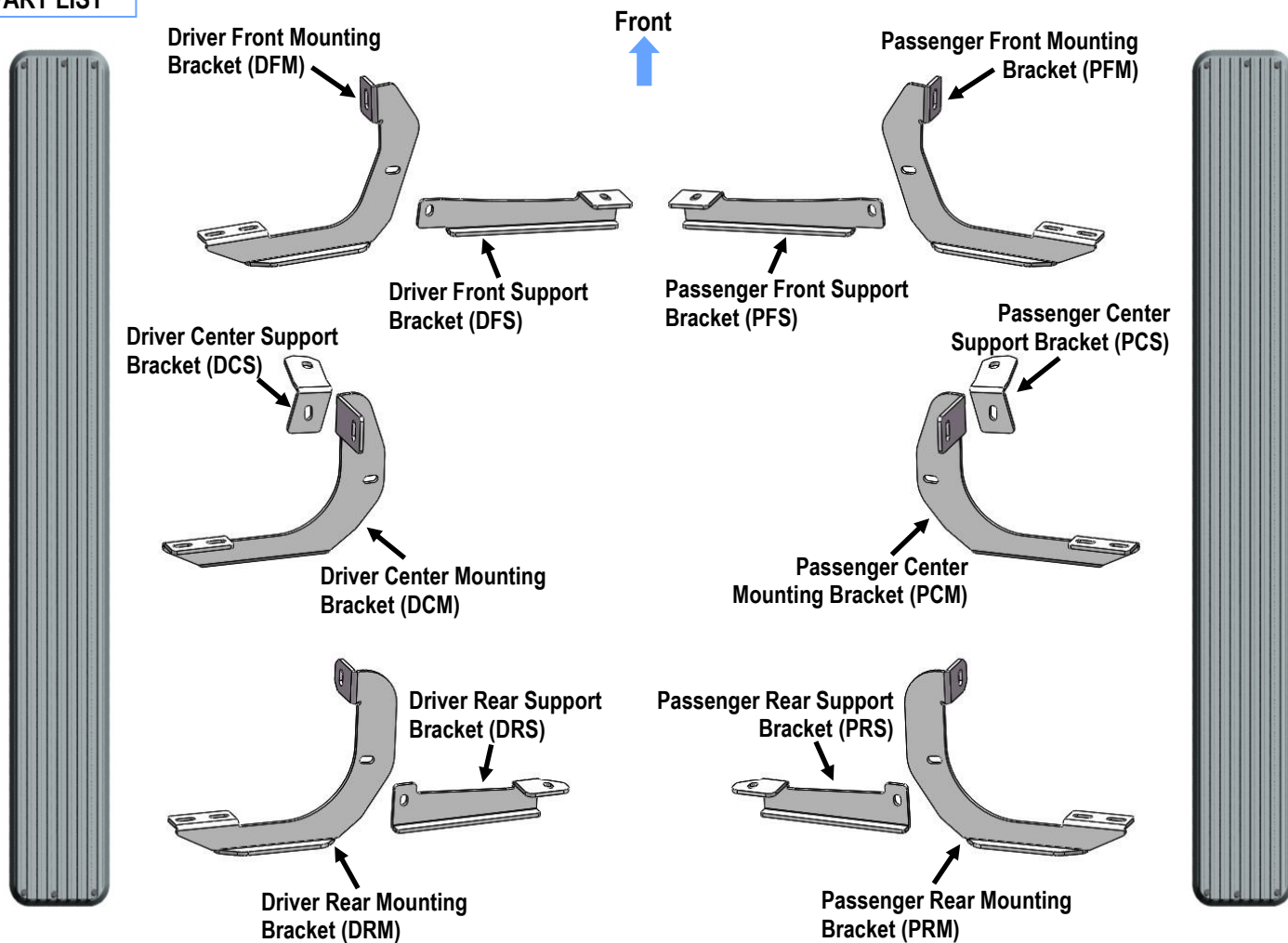

Customer Support: info@iboardauto.com

iBoard®

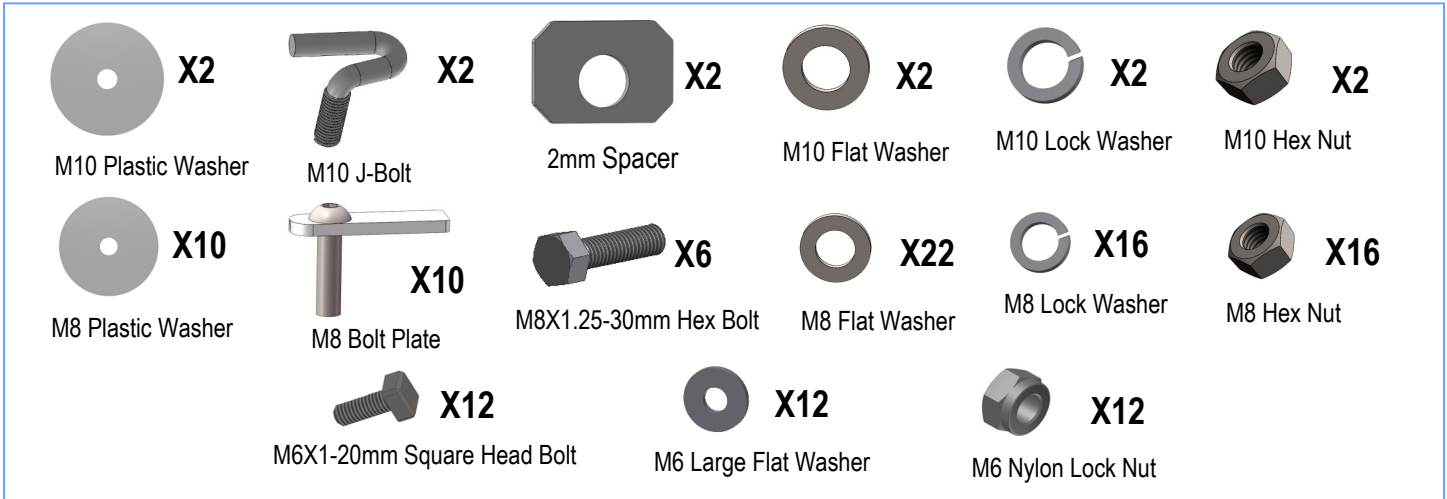

STEP 1

Start installation from the Passenger side front of the vehicle. Identify the mounting holes on body panel, (Fig 1). Remove the rubber plugs from the mounting holes, if equipped.

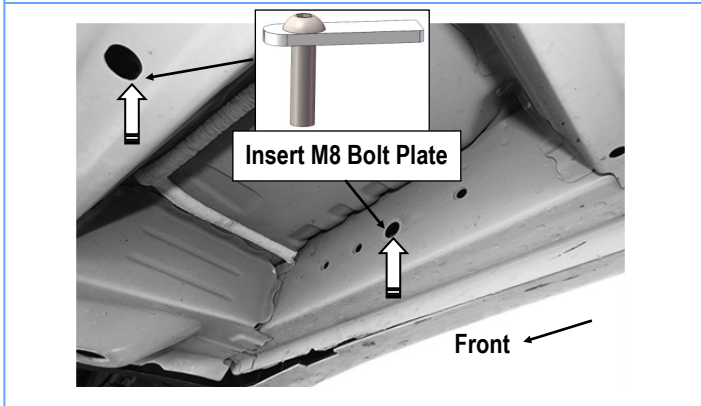

(Fig 1) Passenger Side Front Mounting Location

STEP 2

Assemble Passenger Front Mounting Bracket (PFM) and Passenger Front Support Bracket (PFS) with (1) M8X1.25-30mm Hex Bolt, (2) M8 Flat Washers, (1) M8 Lock Washer and (1) M8 Hex Nut, (Fig 2). Do not fully tighten hardware at this time.

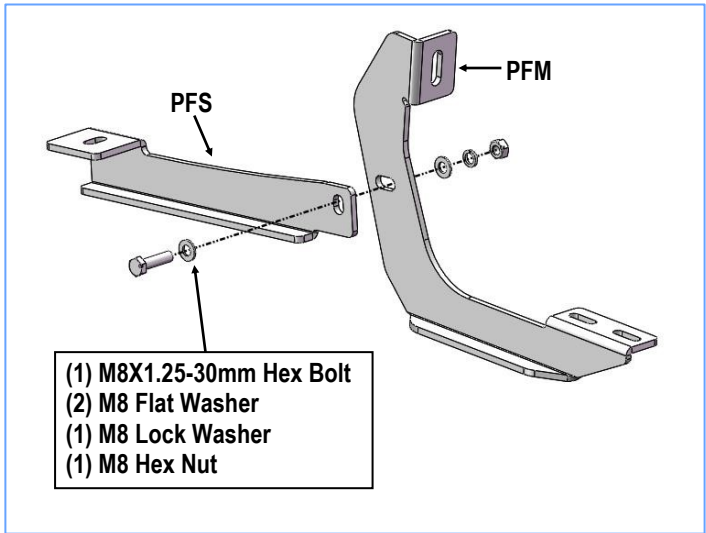

(Fig 2) Passenger Front Mounting Bracket Assembly

STEP 3

Select (2) M8 Bolt Plate. Thread (1) M8 Plastic Washer onto the each M8 Bolt Plate. Insert the M8 Bolt Plate into the front mounting location, (Fig 1).
NOTE: The Plastic Washer is designed to help hold the Bolt Plate in place and to prevent the Bolt Plate from falling into the body panel within installing.

iBoard®

STEP 4

Attach the assembled Passenger Side Front Brackets to the installed (2) M8 Bolt Plates with (2) M8 Flat Washers, (2) M8 Lock Washers and (2) M8 Hex Nuts, (Figs 3 & 4). Do not fully tighten hardware at this time.

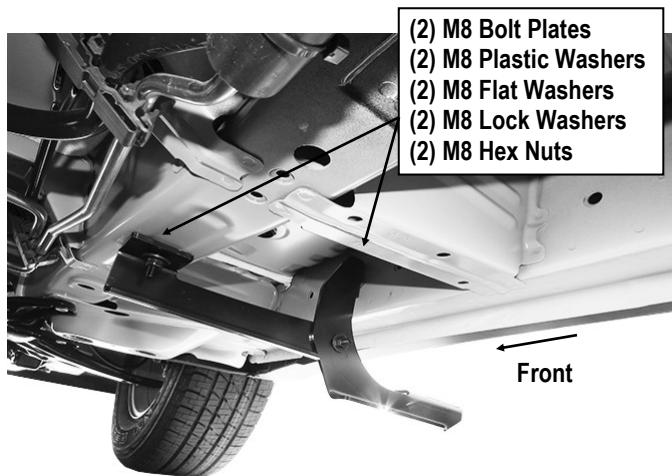

(Fig 3) Passenger Front Side Brackets Installed

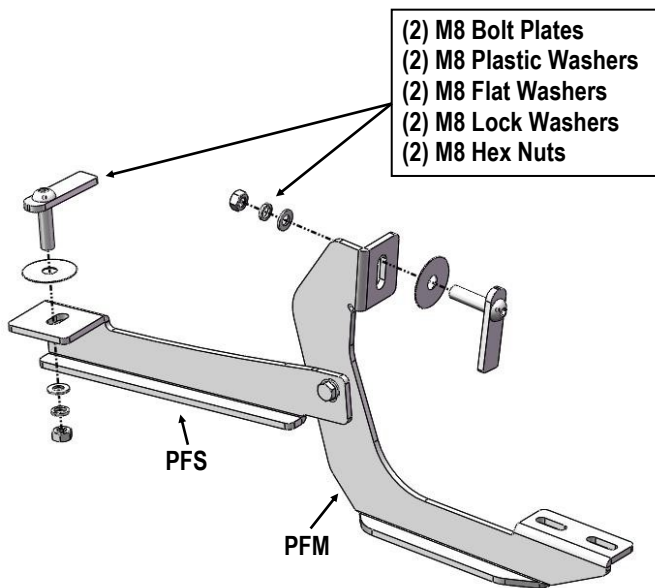

(Fig 4) Passenger Front Side Brackets Installed

STEP 5

Move to the Passenger Side Center Mounting Location, (Fig 5). Remove the rubber plug from the mounting hole on inner body panel, if equipped.

Assemble Passenger Center Mounting Bracket (PCM) and Passenger Center Support Bracket (PCS) with (1) M8X1.25-30mm Hex Bolt, (2) M8 Flat Washers, (1) M8 Lock Washer and (1) M8 Hex Nut, (Fig 6). Do not fully tighten hardware at this time.

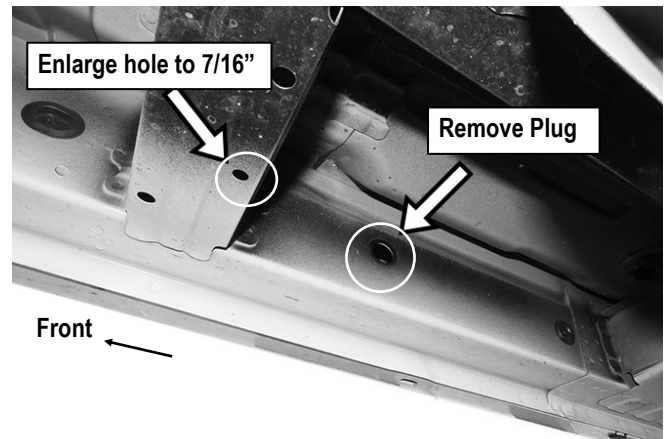

(Fig 5) Passenger Side Center Mounting Location

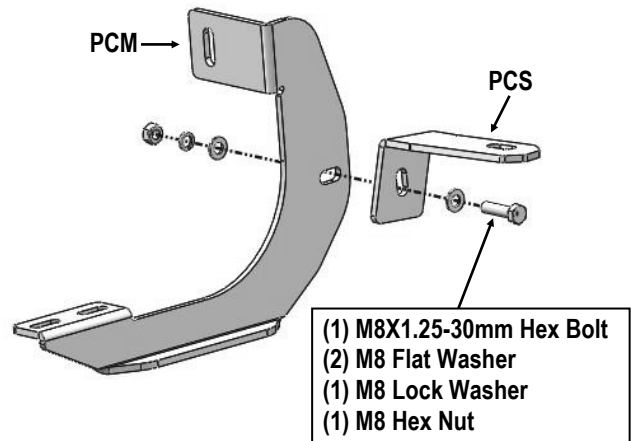

(Fig 6) Passenger Side Center Brackets Assembly

iBoard®

STEP 6

Insert (1) M8 Bolt Plate with (1) M8 Plastic Washer into the hole on the body panel. Repeat **Steps 3-4** to attach the Passenger Center Mounting Bracket to the installed M8 Bolt Plate, (**Figs 7 & 8**). Do not fully tighten hardware at this time.

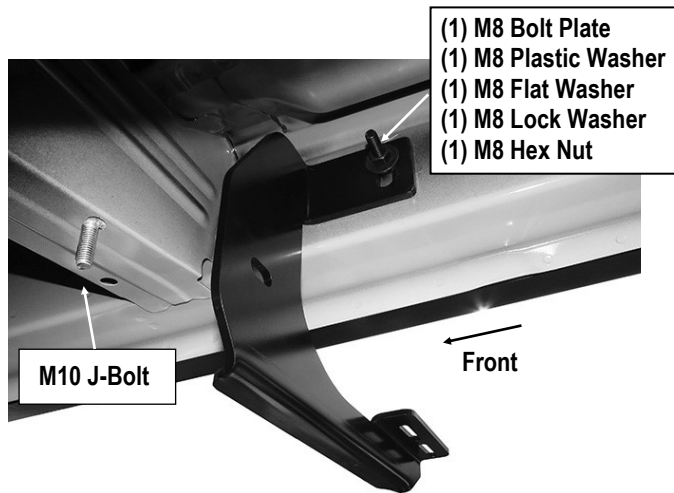

(Fig 7) Passenger Center Mounting Bracket Installed

STEP 7

Hold the Passenger Center Support Bracket (**PCS**) up in position to determine the mounting hole on the bottom of the body panel reinforcement. Insert (1) M10 J-Bolt into the mounting hole. If necessary, use a 7/16" drill bit (not included) to enlarge the hole, (**Fig 5**).

Select (1) M10 Plastic Washer. Thread the M10 Plastic Washer onto the M10 J-Bolt to hold it in place. Attach the Passenger Center Support Bracket (**PCS**) to the installed M10 J-Bolt with (1) 2mm Spacer, (1) M10 Flat Washer, (1) M10 Lock Washer and (1) M10 Hex Nut, (**Figs 8 & 9**). Do not fully tighten hardware at this time.

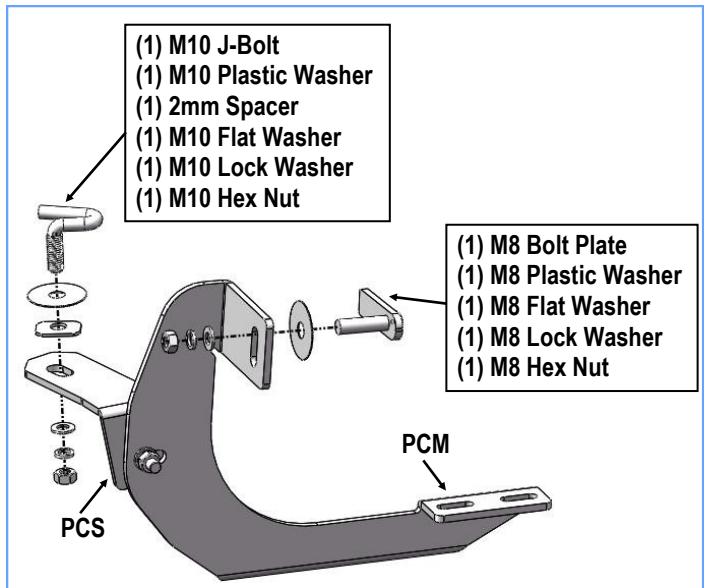

(Fig 8) Passenger Side Center Brackets Installed



(Fig 9) Passenger Side Center Brackets Installed

STEP 8

Move to the passenger side rear mounting location, (**Fig 10**). Repeat **Steps 1-4** to assemble and install the Passenger Rear Mounting Bracket (**PRM**) and Passenger Rear Support Bracket (**PRS**), (**Fig 11**). Do not fully tighten hardware at this time.

iBoard®

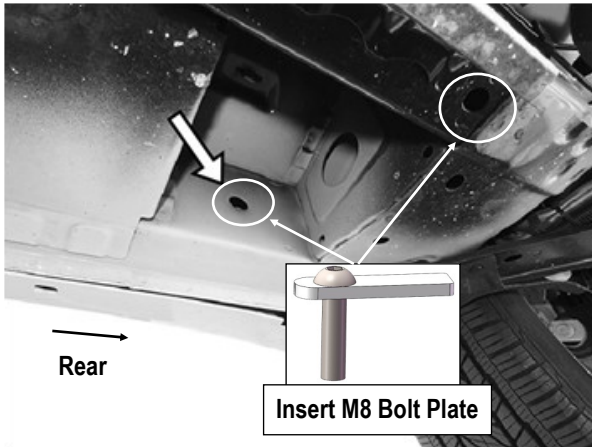

(Fig 10) Passenger Side Rear Brackets Mounting Location

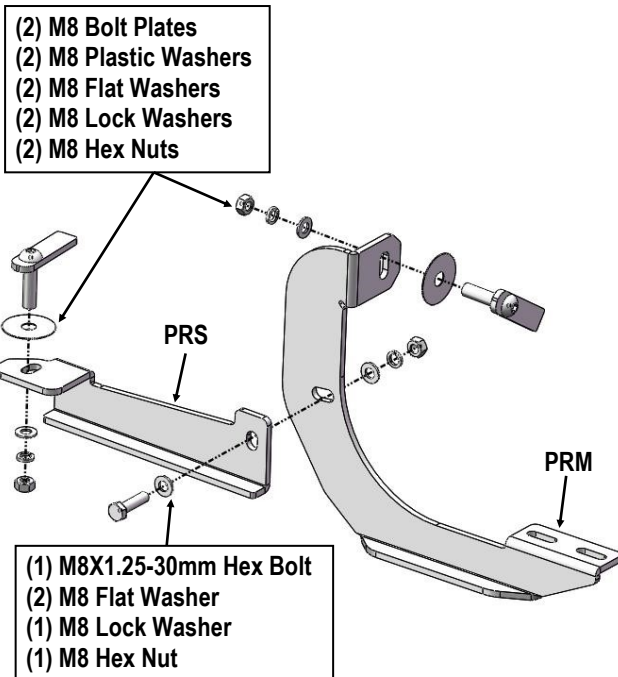

(Fig 11) Passenger Side Rear Brackets Installed

STEP 9

Select a Running Board. Slip (3) M6X1-20mm Square Head Bolts into each bottom channel (Fig 12). Carefully position the Running Board onto the (3) Mounting Brackets.

IMPORTANT: Do not slide the Running Board on the Brackets or the bottom surface of the board will be damaged. Attach the Running Board to each Mounting Brackets with (2) M6x1-20mm Square Head Bolts, (2) M6 Large Flat Washers and (2) M6 X1 Nylon Lock Nuts (Fig 13). Do not fully tighten at this time.

Level and adjust the Running Board and fully tighten all hardware.



(Fig 12) Slip M6X1-20mm Square Head Bolts Into The Bottom Channels

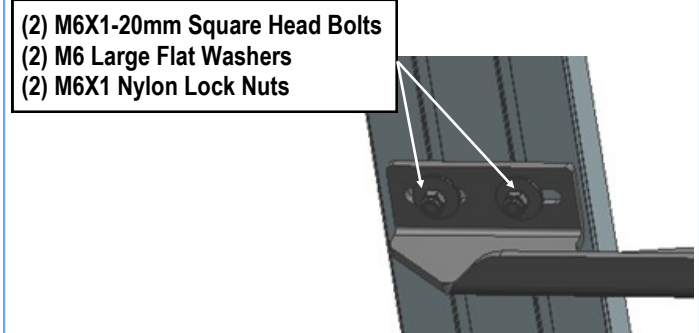

(Fig 13) Running Board Installed Onto Mounting Bracket

STEP 10

Repeat **Steps 1-9** for the other side Running Board installation. The installation is completed.

Attention

Do periodic inspections to the installation to make sure that all hardware is secure and tight. In order to protect your bars/boards, please use only mild soap/non-abrasive products for cleaning.