

# iArmor<sup>®</sup>

## iArmor<sup>®</sup> by APS

PART#: IA-S060

### BEFORE INSTALLATION

REMOVE CONTENTS FROM BOX. VERIFY ALL PARTS ARE PRESENT. READ INSTRUCTIONS CAREFULLY BEFORE STARTING INSTALLATION. ASSISTANCE IS RECOMMENDED. THANK YOU FOR CHOOSING OUR PRODUCT!

**\*ROCKER PANEL MOUNT**

**\*DRILLING IS REQUIRED/ NO TRIMMING REQUIRED**

### Torque Value

Fastener Size	Tightening Torque (ft-lbs)	Required
6mm	6-7	√
8mm	16-18	√
10mm	31-32	X
12mm	56-58	X
14mm	92-94	X

### PART LIST

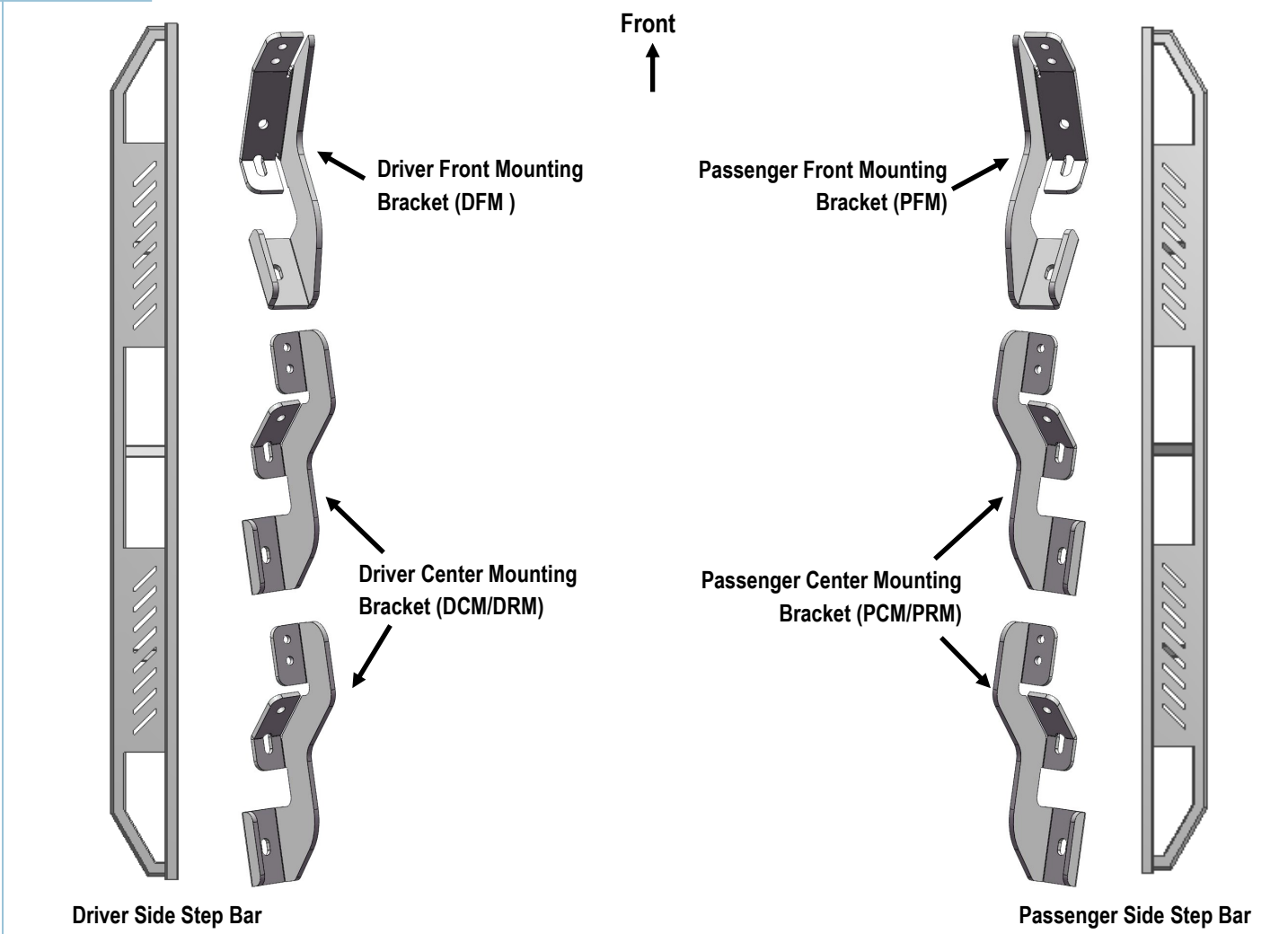

Customer Support: [info@iarmorauto.com](mailto:info@iarmorauto.com)

# iArmor®

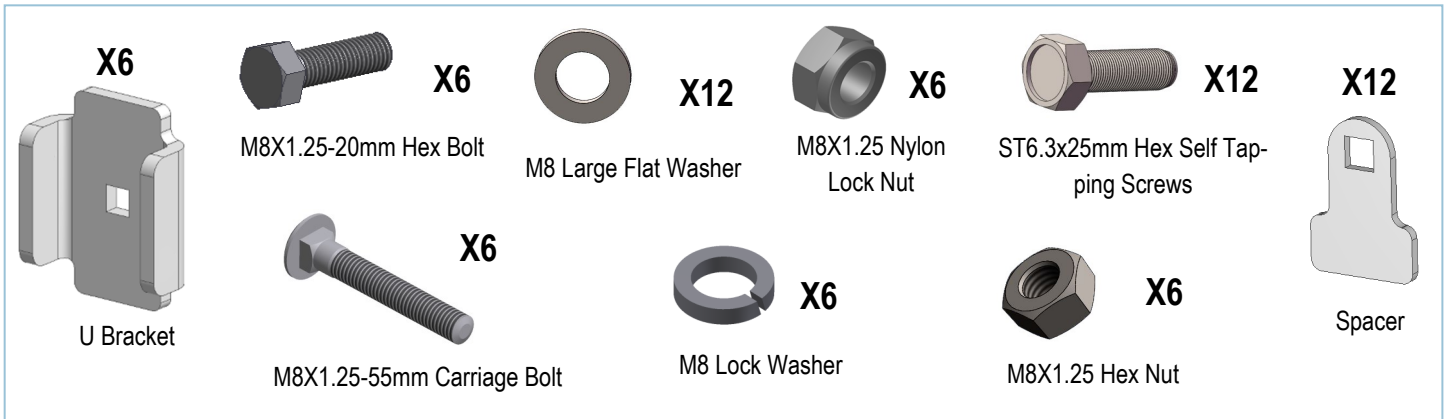

The instruction here is for your reference only. We strongly recommend the professional installer for best result. We are not responsible for any damage caused by the installation.

## STEP 1

Start installation from the Driver Side. Using the Bracket location Chart below, lay out and mark the (3) driver side bracket mounting locations on pinch weld with a pencil. **Note: suggest attach the brackets onto the positions and use the bracket as template, make sure the (3) brackets are on the same level and then mark the hole locations on the pinch weld.**

Drill (3) 5/16" holes on the pinch weld according to the marked locations.

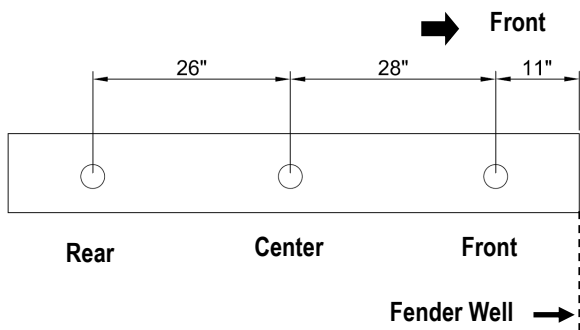

Driver Side Pinch Weld Bracket Location Chart

## STEP 2

Using (1) M8 x1.25-20mm Hex Bolts (2) M8 Large Flat Washers (1) M8X1.25 Nylon Lock Nut, attach the Driver Front Mounting Bracket (DFM) to the previously drilled Pinch Weld hole from **Step 1**. And secure the bracket onto the frame rail with (2) ST6.3x25mm Self Tapping screws, (Fig 1).

**Note: 1/5" holes may require to drill on the frame rail on some models.**

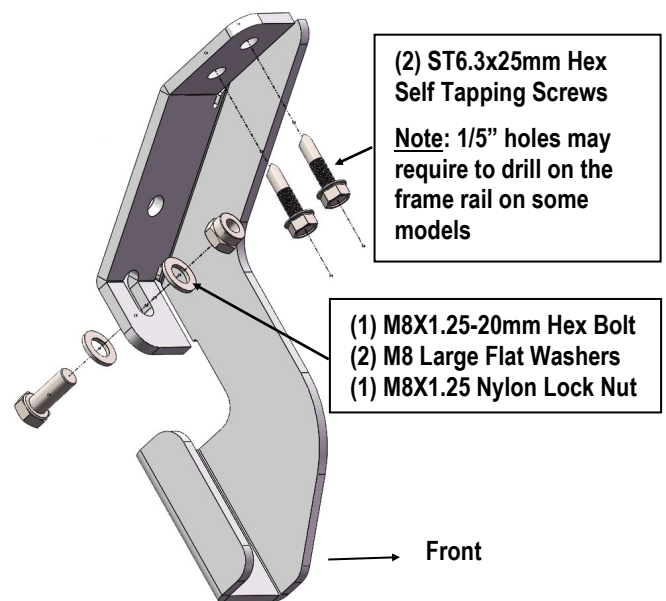

(Fig 1) Driver Front Mounting Bracket (DFM) Installation Pictured

# iArmor®

## STEP 3

Repeat **Steps 2** to install Driver Center & Rear Mounting Brackets (**DCM/DRM**) (**Fig 2**). Do not fully tighten hardware at this time.

## STEP 4

Once all (3) driver side mounting brackets are installed, select and attach the Driver Side Step Bar onto the Mounting Brackets with (3) U Brackets, (6) Spacers, (3) M8X1.25-55mm Carriage Bolts, (3) M8 Large Flat Washers, (3) M8 Lock Washers and (3) M8X1.25 Hex Nuts, (**Fig 3**). Do not fully tighten hardware at this time.

## STEP 5

Properly level and adjust the Step Bar and fully tighten all hardware.

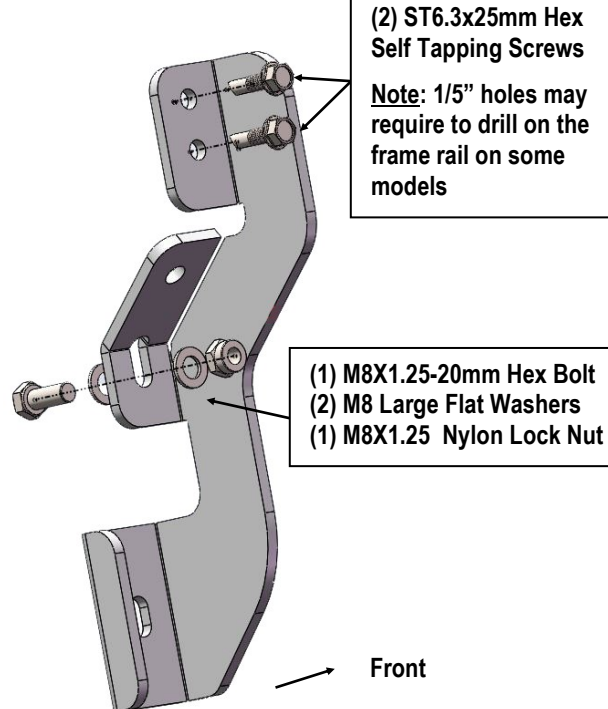

(Fig 2) Driver Center & Rear Mounting Brackets (DCM/DRM) Installation Pictured

**NOTE:** Torque all M8 X1.25-55mm Carriage Bolts to 16~18 lb-ft. Don't over tighten, or the aluminum square bars will be damaged by the brackets

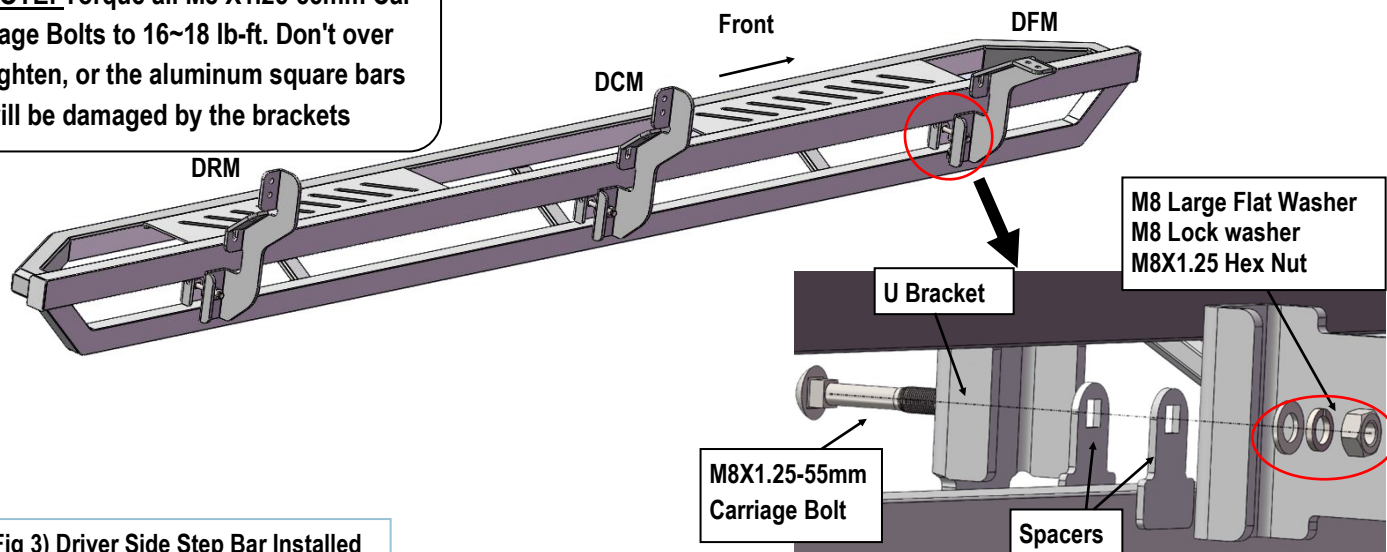

(Fig 3) Driver Side Step Bar Installed

# iArmor<sup>®</sup>

## STEP 6

Move to the passenger side of the vehicle. Repeat **Steps 1-5** to install passenger side step bar.

Installation completed.

### Attention

**Do periodic inspections to the installation to make sure that all hardware is secure and tight.**

**In order to protect your bars/boards, please use only mild soap/non-abrasive products for cleaning.**