

iArmor[®]

iArmor[®] by APS

PART#: IA-S975

BEFORE INSTALLATION

REMOVE CONTENTS FROM BOX. VERIFY ALL PARTS ARE PRESENT. READ INSTRUCTIONS CAREFULLY BEFORE STARTING INSTALLATION. ASSISTANCE IS RECOMMENDED. THANK YOU FOR CHOOSING OUR PRODUCT!

***ROCKER PANEL MOUNT**

***NO DRILLING / TRIMMING REQUIRED**

Torque Value

Fastener Size	Tightening Torque (ft-lbs)	Required
6mm	6-7	X
8mm	16-18	√
10mm	31-32	√
12mm	56-58	X
14mm	92-94	X

PART LIST

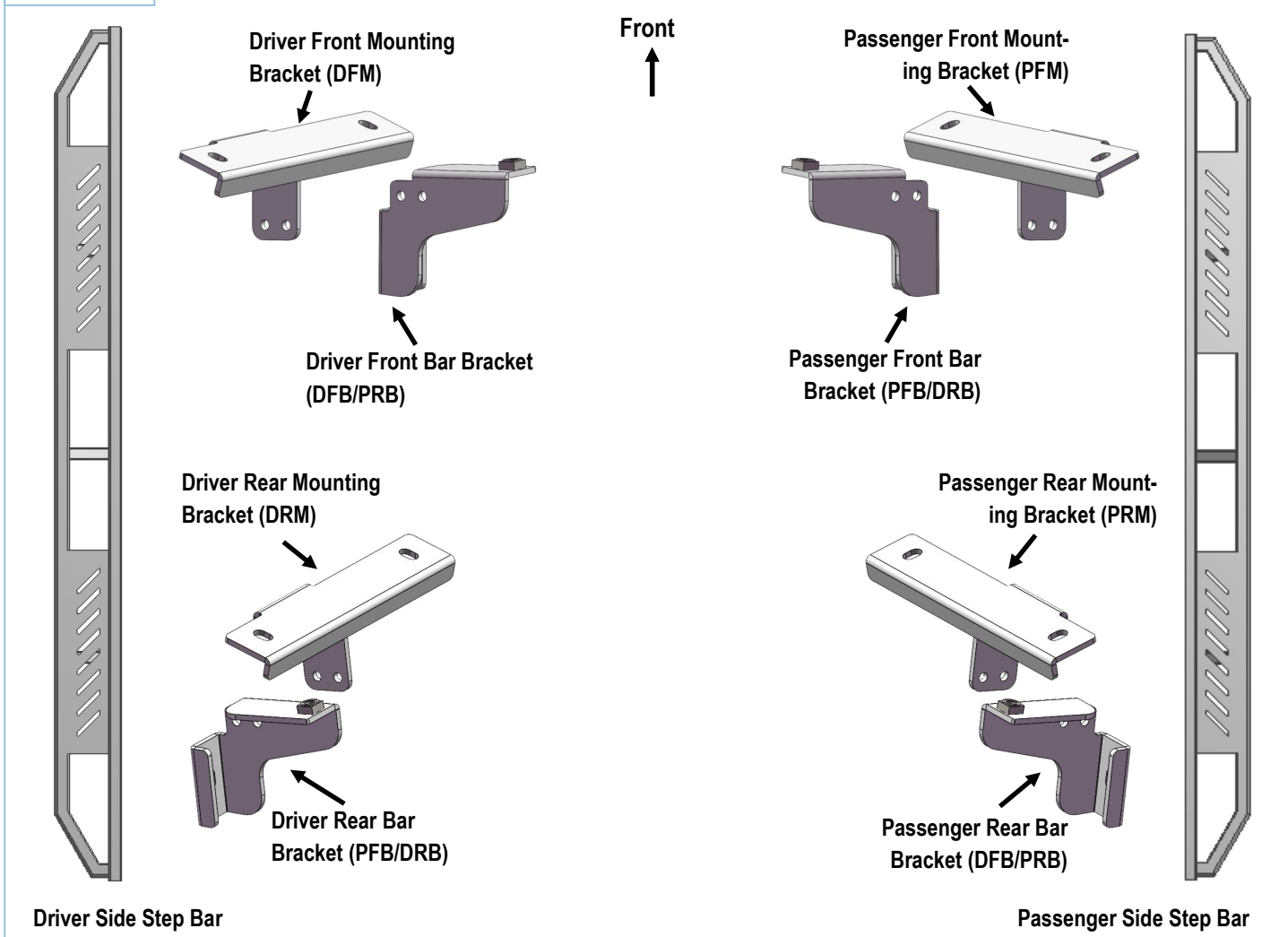

Customer Support: info@iarmorauto.com

iArmor[®]

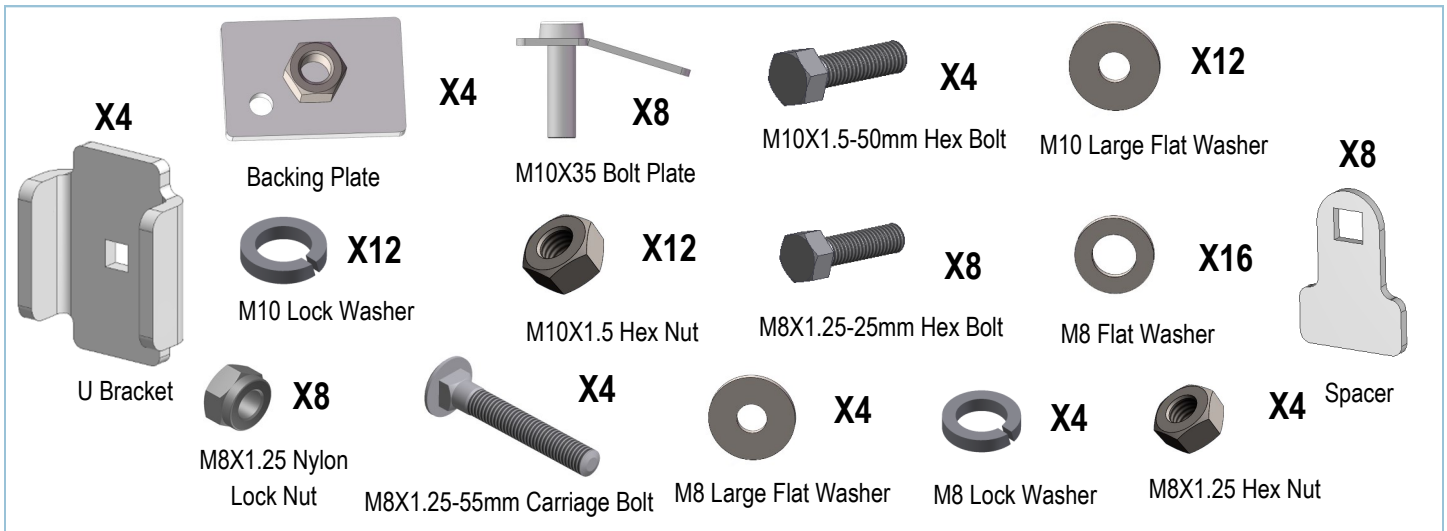

The instruction here is for your reference only. We strongly recommend the professional installer for best result. We are not responsible for any damage caused by the installation.

STEP 1

Start on the passenger side of the vehicle, locate the (9) rubber plugs along the lower body panel. From the front location, remove the 3rd and 4th round plugs (**Fig 1**). Select (2) M10X35 Bolt plates, (**Fig 2**). Check the location for body sealant and scrape away excess as necessary, (**Fig 3**). Insert each Bolt Plate into the factory hole with the long end of the plates facing each other, (**Fig 1 & 3**).

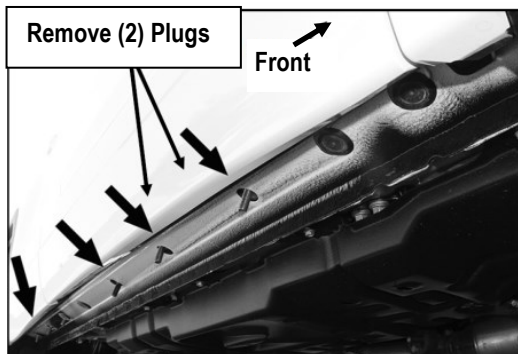

(Fig 1) Use The 3rd And 4th Mounting Hole From The Front Fender Opening For Passenger Front Mounting Bracket Location



(Fig 2) M10X35 Bolt Plate



(Fig 3) From All Locations Before Installing Bracket

STEP 2

Assemble Passenger Front Bar Bracket (**PFB/DRB**) and Passenger Front Mounting Bracket (**PFM**) with (2) M8X1.25-25mm Hex Bolts, (4) M8 Flat Washers and (2) M8X1.25 Nylon Lock Nuts (**Fig 4**).

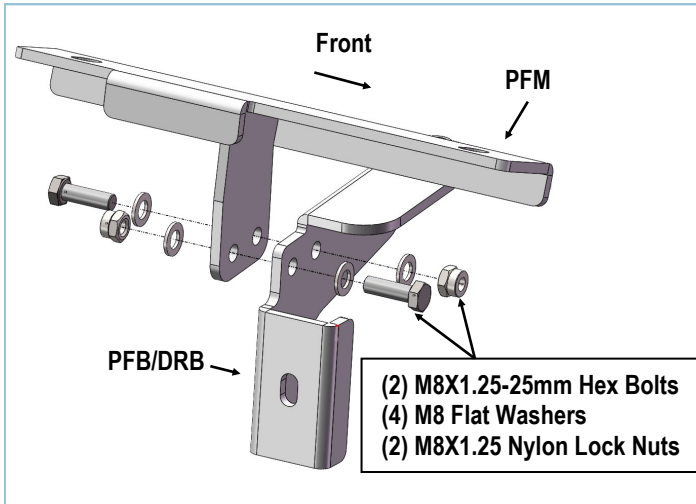

(Fig 4) Passenger Side Front Brackets Assembly

STEP 3

Hold the Passenger Front Mounting Bracket over the Bolt Plates and line up the (2) mounting holes. Secure the Bracket to the Bolt Plates with (2) M10 Large Flat Washers, (2) M10 Lock Washers and (2) M10X1.5 Hex Nuts, (Fig 5). Snug but do not tighten hardware at this time.

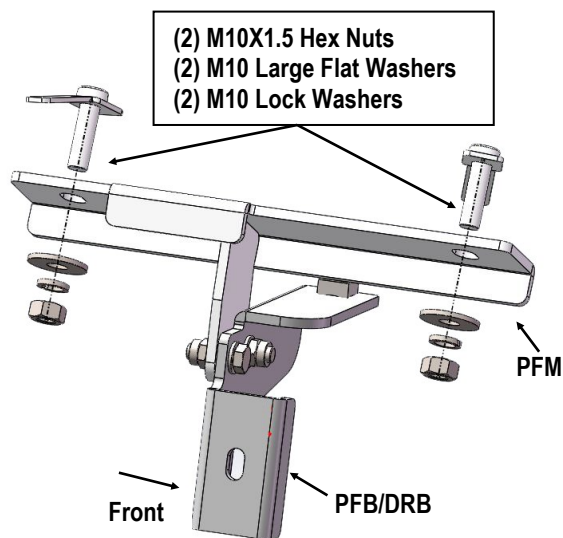

(Fig 5) Passenger Front Mounting Bracket (PFM) Installation

STEP 4

Next, select (1) Backing Plate, (1) M10X1.5 Hex Nut and (1) M10X1.5-50mm Hex Bolt, (Fig 6). Thread the M10X1.5 Hex Nut all the way down the long Hex Bolt. Screw the Hex Bolt and Nut a few threads into and through the Nut welded onto the back tab on the Driver Front Bar Bracket. Insert the Backing Plate with the welded socket facing down, into the space between the Driver Front Bar Bracket and the floor panel behind the pinch weld, (Fig 6). Tighten the Hex Bolt into the socket on the Backing Plate until the Plate is close to but not touching the floor panel. Do not tighten hardware at this time.

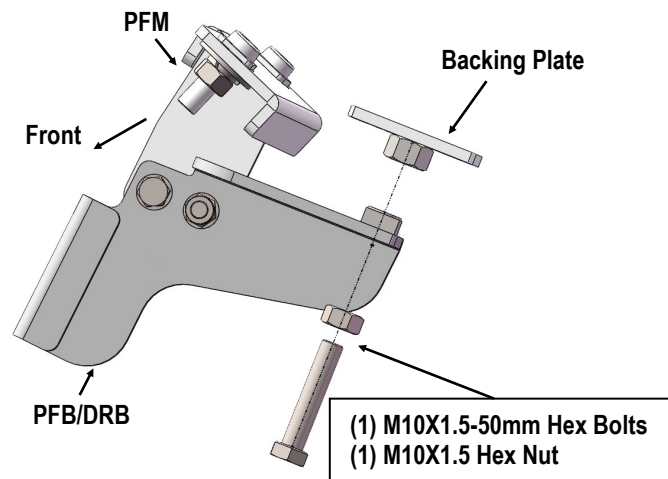

(Fig 6) Passenger Front Bar Bracket (PFB/DRB) Installation

STEP 5

Continue along the body to the 7th and 8th rubber plugs, (Fig 7). Repeat **Steps 1-4** to install the passenger side rear Brackets, (Fig 8).

iArmor®

Mounting Location For Rear Bracket (Use Last 2 Holes Along Body)

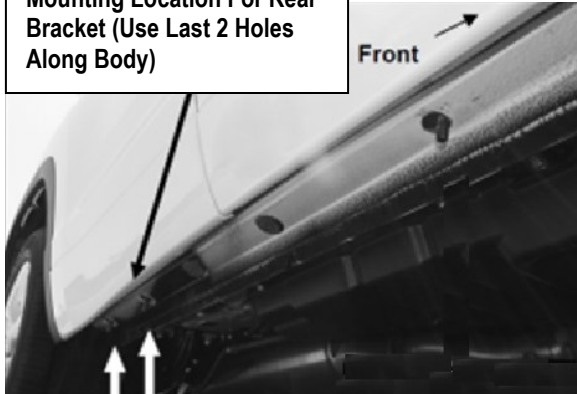

(Fig 7) Passenger Side Rear Bracket Location

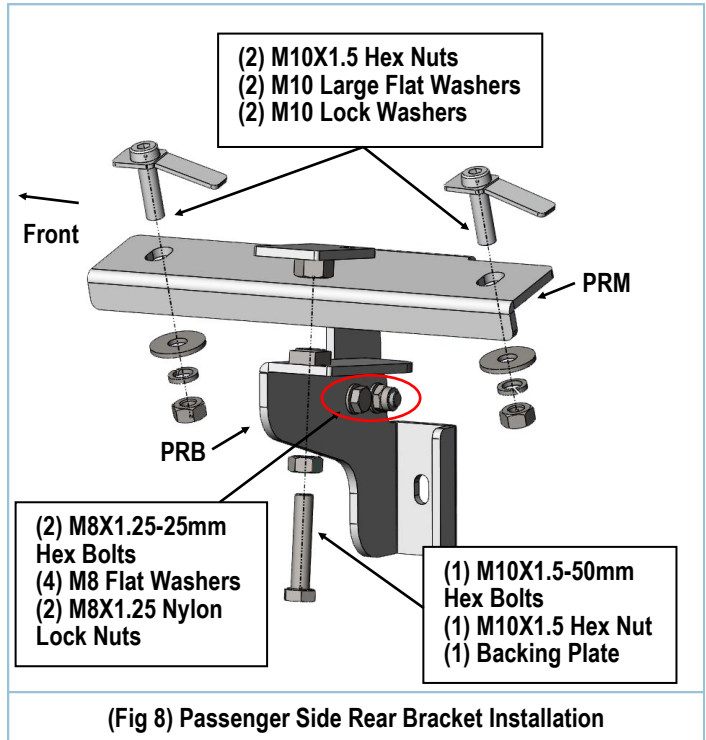

(Fig 8) Passenger Side Rear Bracket Installation

STEP 6

Once all (2) passenger side mounting brackets are installed, select and attach the Passenger Side Step Bar onto the Mounting Brackets with (2) U Brackets, (4) Spacers, (2) M8X1.25-55mm Carriage Bolts, (2) M8 Large Flat Washers, (2) M8 Lock Washers and (2) M8X1.25 Hex Nuts (Fig 9). Do not fully tighten hardware at this time.

NOTE: Torque all M8 X1.25-55mm Carriage Bolts to 16~18 lb-ft. Don't over tighten, or the aluminum square bars will be damaged by the brackets

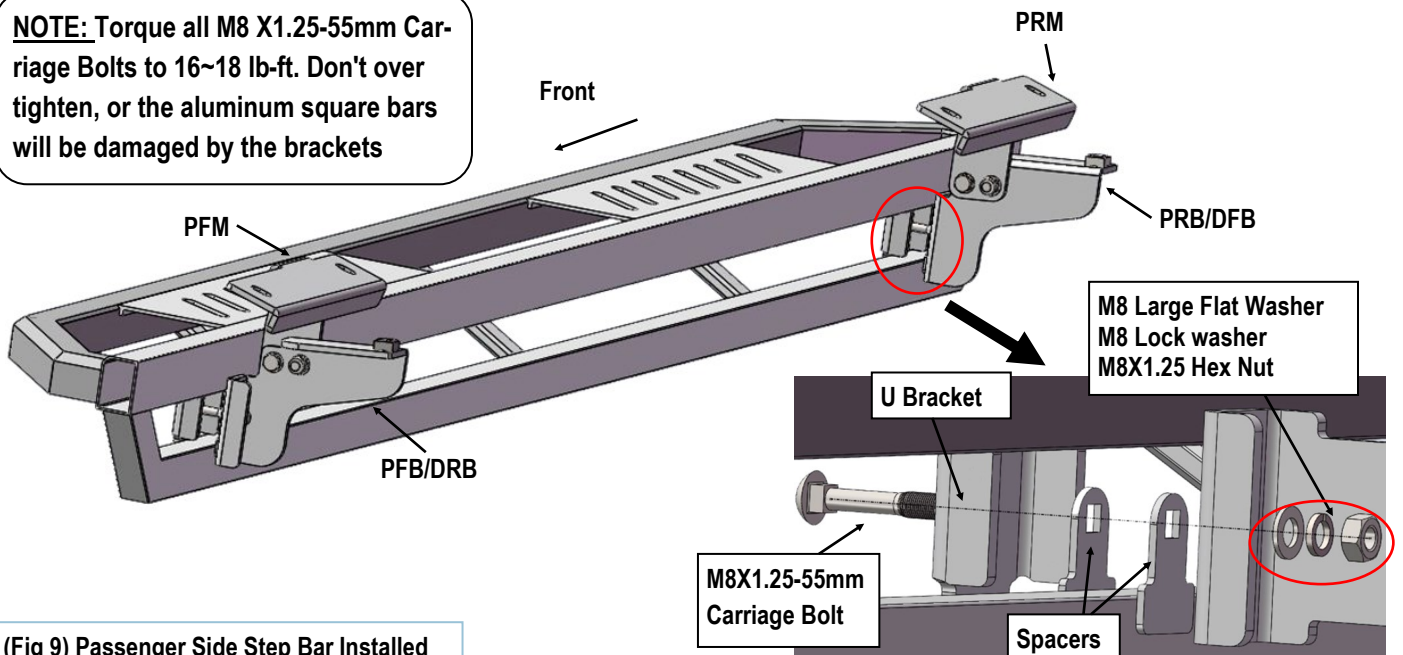

(Fig 9) Passenger Side Step Bar Installed

iArmor[®]

STEP 7

Properly level and adjust the Step Bar and fully tighten all hardware.

STEP 8

Move to the driver side of the vehicle. Repeat **Steps 1-7** to install driver side step bar.

Installation completed.

Attention

Do periodic inspections to the installation to make sure that all hardware is secure and tight.

In order to protect your bars/boards, please use only mild soap/non-abrasive products for cleaning.