

iArmor[®]

iArmor[®] by APS

PART#: IA-S229H

BEFORE INSTALLATION

REMOVE CONTENTS FROM BOX. VERIFY ALL PARTS ARE PRESENT. READ INSTRUCTIONS CAREFULLY BEFORE STARTING INSTALLATION. ASSISTANCE IS RECOMMENDED. THANK YOU FOR CHOOSING OUR PRODUCT!

***ROCKER PANEL MOUNT**

***NO DRILLING / TRIMMING REQUIRED**

Torque Value

Fastener Size	Tightening Torque (ft-lbs)	Required
6mm	6-7	X
8mm	16-18	√
10mm	31-32	√
12mm	56-58	X
14mm	92-94	X

PART LIST

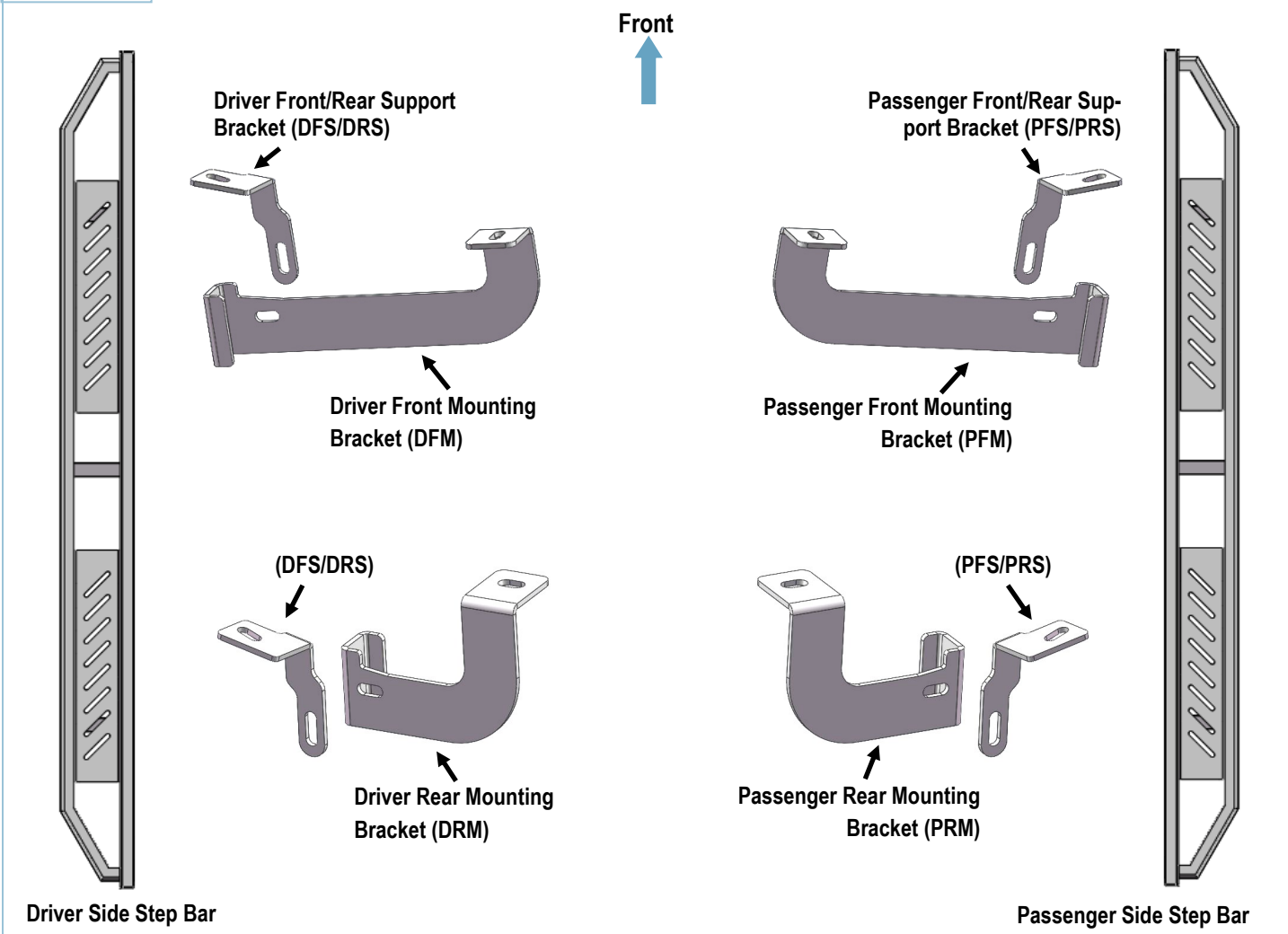

Customer Support: info@iarmorauto.com

iArmor[®]

Hardware Package A (For Bracket Installation)

Item	QTY	Description	Item	QTY	Description
1#	4	U Brackets	5#	2	M10 Large Flat Washers
2#	2	M10X45 Bolt Plates	6#	14	M10 Flat Washers
3#	6	M10X30 Bolt Plates	7#	12	M10 Lock Washers
4#	4	M10X1.5-30mm Hex Bolts	8#	12	M10X1.5 Hex Nuts

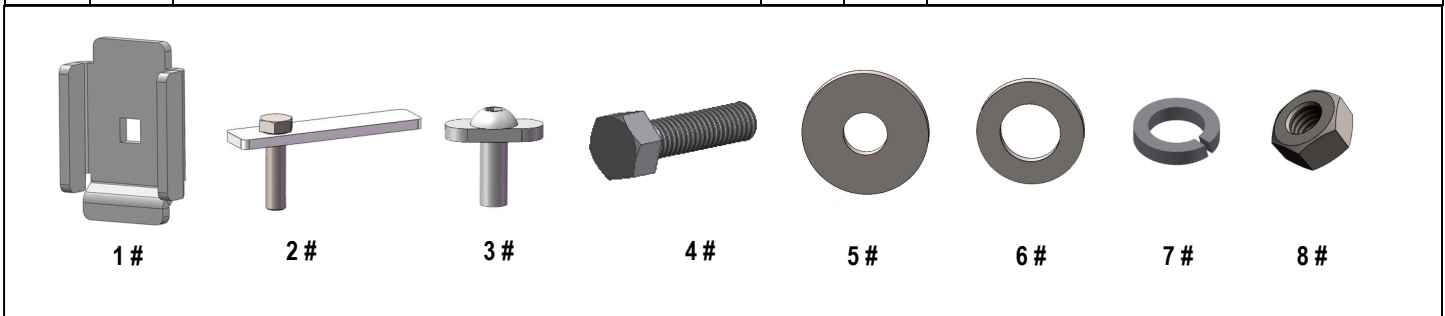

Hardware Package B (For Step Bar Installation)

Item	QTY	Description	Item	QTY	Description
1#	4	M8X1.25-55mm Carriage Bolts	3#	4	M8 Lock Washers
2#	4	M8 Large Flat Washers	4#	4	M8 Hex Nuts

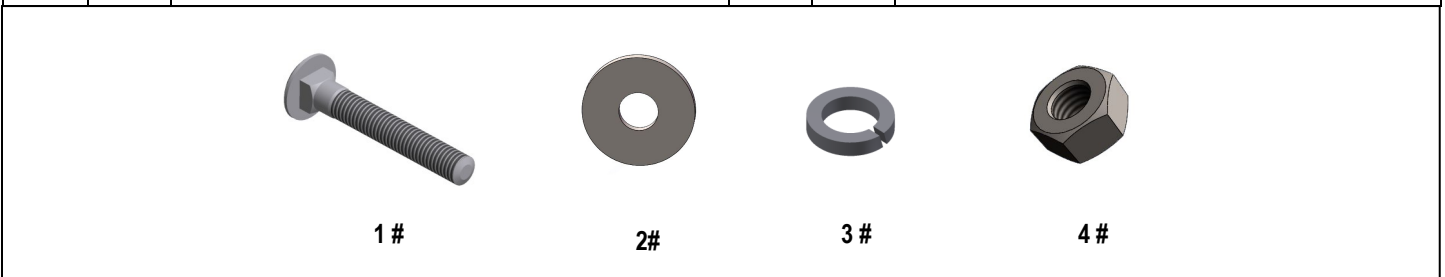

iArmor®

The instruction here is for your reference only. We strongly recommend the professional installer for best result. We are not responsible for any damage caused by the installation.

STEP 1

Start installation on the passenger side of the vehicle, (Fig 1). Bolt M10X45 Bolt Plate and M10X30 Bolt Plate as shown.

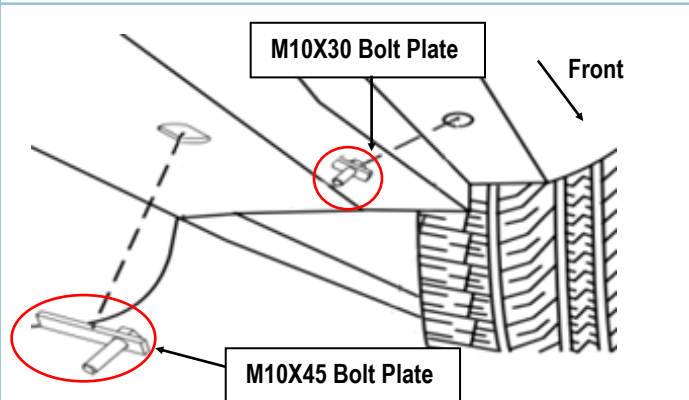

(Fig 1) Passenger Front Mounting Location

STEP 2

Start from passenger front side. Select Passenger Front Mounting Bracket (PFM) and Passenger Front Support Bracket (PFS/PRS). Attach Support Bracket to the Mounting Bracket with (1) M10X1.5-30mm Hex Bolt, (1) M10 Lock Washer, (1) M10X1.5 Hex Nut and (2) M10 Flat Washers, (Fig 2). Do not fully tighten hardware at this time.

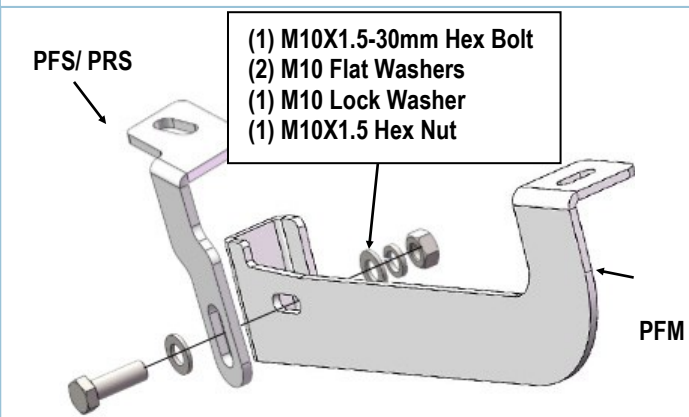

(Fig 2) Passenger Front Mounting Bracket Assembly

STEP 3

Install Passenger Front Mounting Bracket (PFM) to the vehicle using (1) M10X45 Bolt Plate, (1) M10 Lock Washer, (1) M10X1.5 Hex Nut and (1) M10 Large Flat Washer, (Fig 3). Attach Passenger Front Support Bracket (PFS/PRS) to the vehicle with (1) M10X30 Bolt Plate, (1) M10 Lock Washer, (1) M10X1.5 Hex Nut and (1) M10 Flat Washer, (Fig 3). Do not fully tighten hardware at this time.

STEP 4

Move to passenger rear side, repeat step 2 for Passenger Rear Mounting Bracket (PRM) and Passenger Rear Support Bracket (PFS/PRS) assembly.

Next, attach Passenger Rear Mounting Bracket (PRM) and Passenger Rear Support Bracket (PFS/PRS) with (2) M10X30 Bolt Plate, (2) M10 Lock Washer, (2) M10X1.5 Hex Nut and (4) M10 Flat Washer, (Fig 4). Do not tighten hardware at this time.

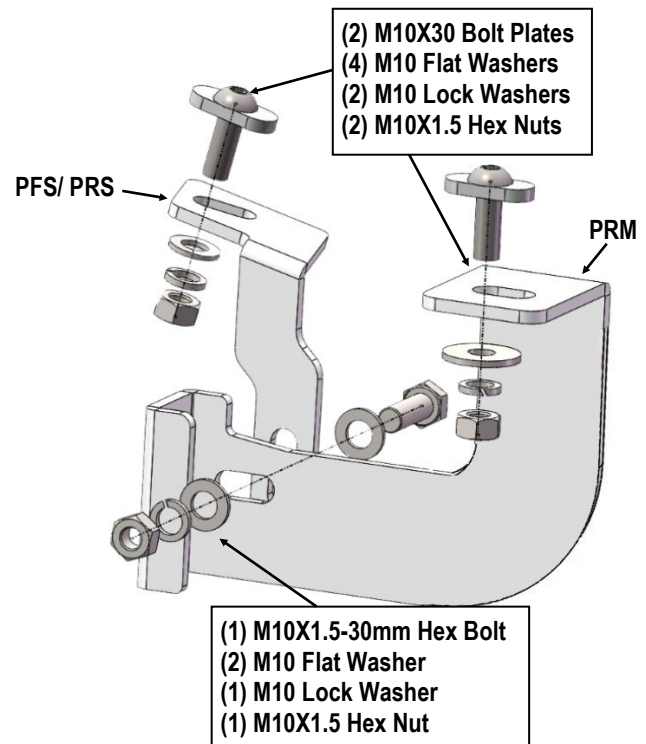

(Fig 4) Passenger Rear Mounting Bracket Installation

iArmor®

STEP 5

Once all (2) passenger side mounting brackets are installed, select and attach the Passenger Side Step Bar onto the Mounting Brackets with (2) U Brackets, (2) M8X1.25-55mm Carriage Bolts, (2) M8 Large Flat Washers, (2) M8 Lock Washers and (2) M8X1.25 Hex Nuts (**Fig 5**). Do not fully tighten hardware at this time.

STEP 6

Properly level and adjust the Step Bar and fully tighten all hardware.

STEP 7

Move to the driver side of the vehicle. Repeat **Steps 1-6** to install driver side step bar.

Installation completed.

Attention

Do periodic inspections to the installation to make sure that all hardware is secure and tight.

In order to protect your bars/boards, please use mild soap/non-abrasive products for cleaning only.

NOTE: Torque all M8 X1.25-55mm Carriage Bolts to 16~18 lb-ft. Don't over tighten, or the square bars will be damaged by the brackets

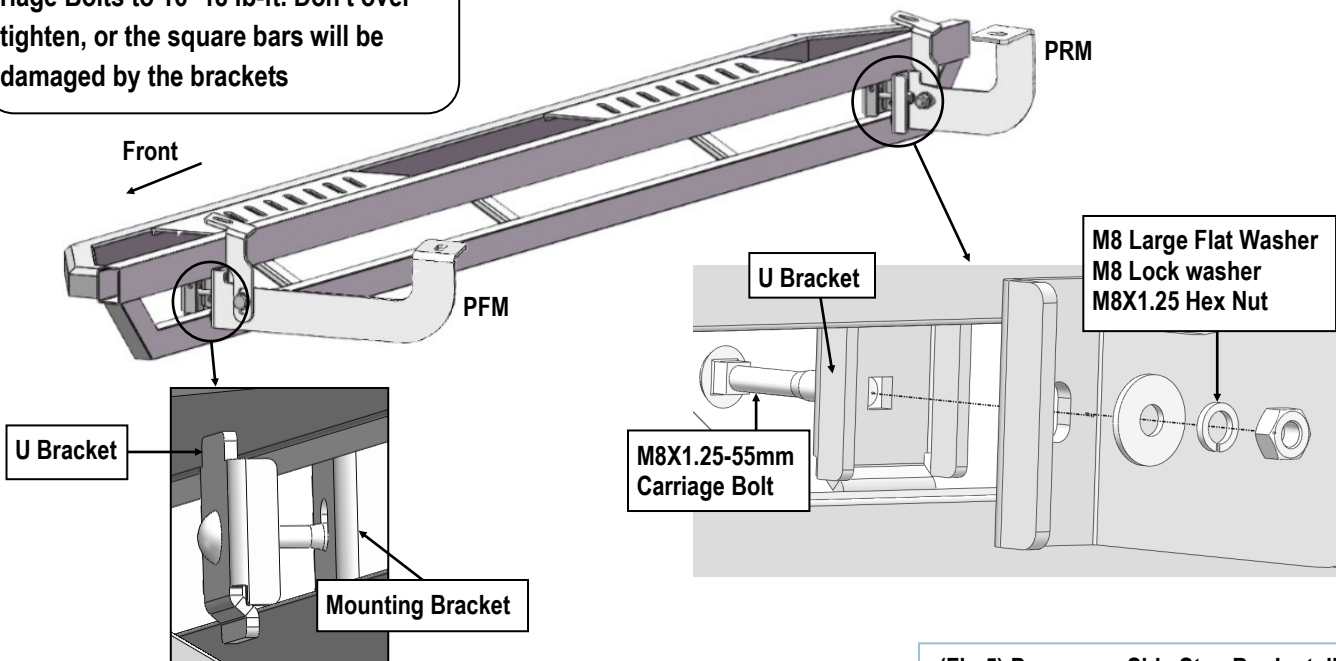

(Fig 5) Passenger Side Step Bar Installation