

# iArmor<sup>®</sup>

## iArmor<sup>®</sup> by APS

PART#: IA-S229

### BEFORE INSTALLATION

REMOVE CONTENTS FROM BOX. VERIFY ALL PARTS ARE PRESENT. READ INSTRUCTIONS CAREFULLY BEFORE STARTING INSTALLATION. ASSISTANCE IS RECOMMENDED. THANK YOU FOR CHOOSING OUR PRODUCT!

| Fastener Size | Tightening Torque (ft-lbs) |
|---------------|----------------------------|
| 6mm           | 6-7                        |
| 8mm           | 16-18                      |
| 10mm          | 31-32                      |
| 12mm          | 56-58                      |
| 14mm          | 92-94                      |

### PART LIST

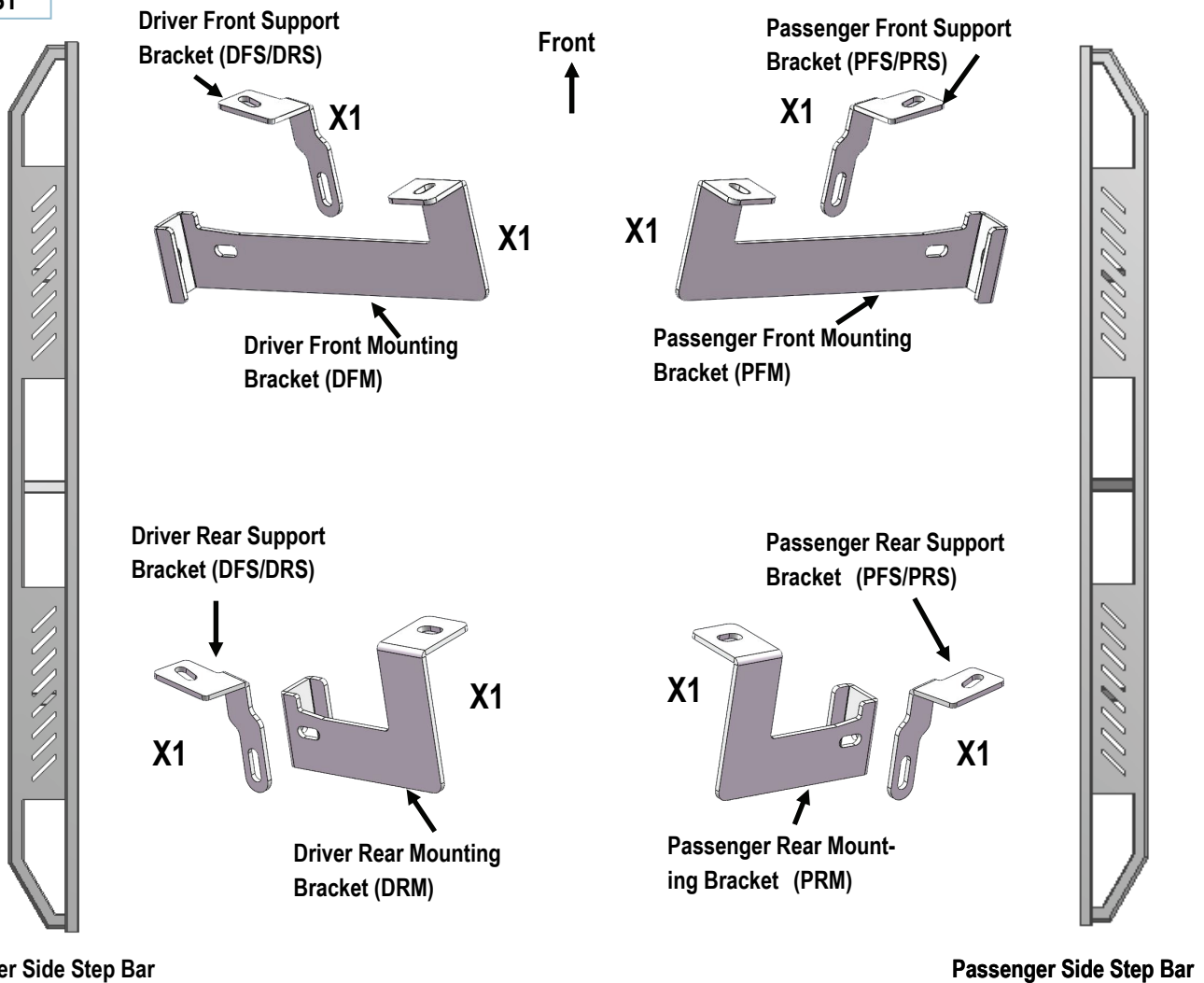

Customer Support: [info@iarmorauto.com](mailto:info@iarmorauto.com)

# iArmor®

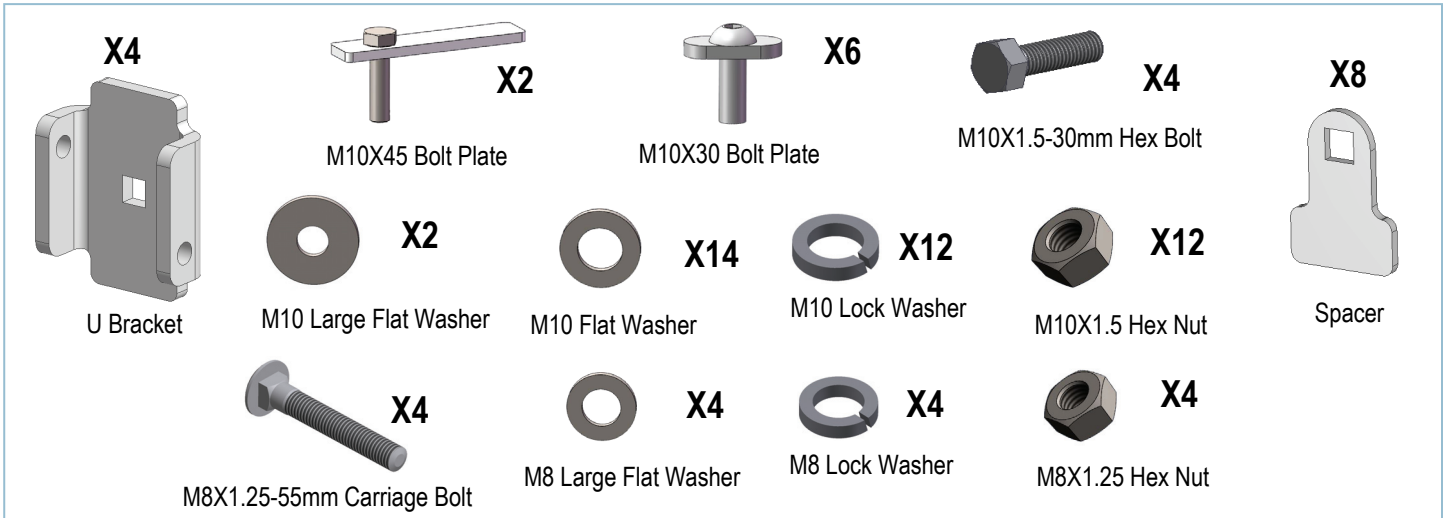

The instruction here is for your reference only. We strongly recommend the professional installer for best result. We are not responsible for any damage caused by the installation.

## STEP 1

Start installation on the passenger side of the vehicle, (Fig 1). Bolt M10X45 Bolt Plate and M10X30 Bolt Plate as shown.

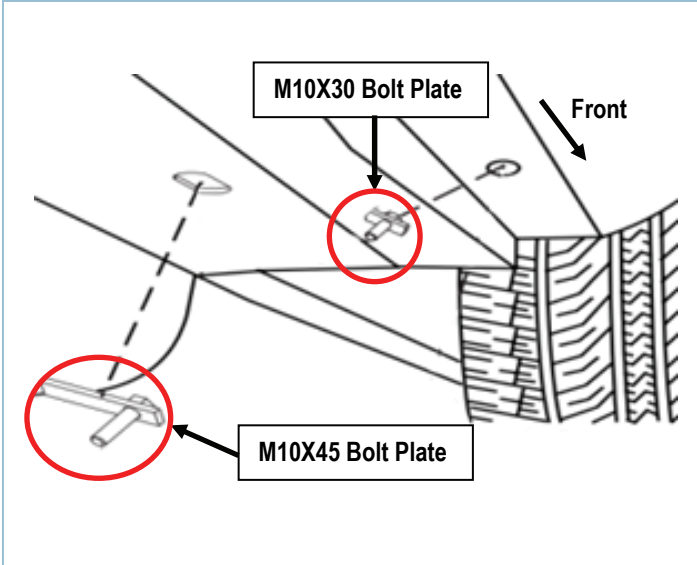

(Fig 1) Passenger Front Mounting Location Pictured

## STEP 2

Start from passenger front side. Select Passenger Front Mounting Bracket (PFM) and Passenger Front Support Bracket (PFS/PRS). Attach Support Bracket to the Mounting Bracket with (1) M10X1.5-30mm Hex Bolt, (1) M10 Lock Washer, (1) M10X1.5 Hex Nut and (2) M10 Flat Washers, (Fig 2). Do not fully tighten hardware at this time.

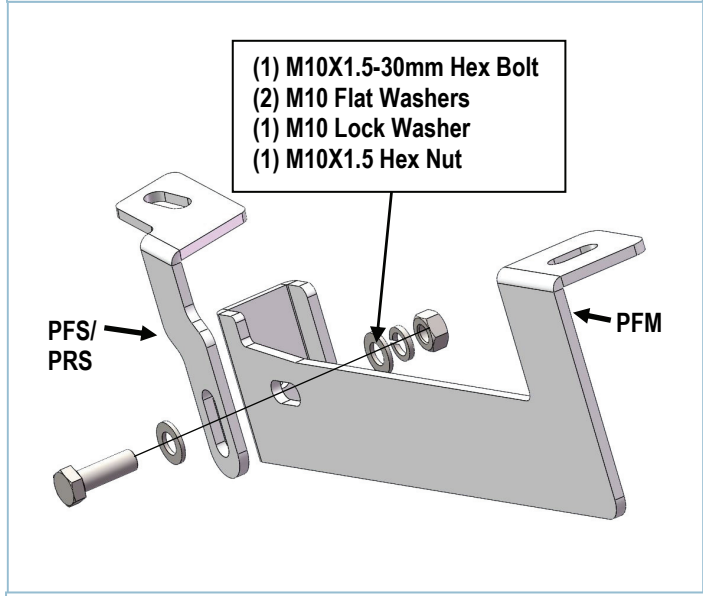

(Fig 2) Passenger Front Mounting Bracket Assembly

# iArmor<sup>®</sup>

## STEP 3

Install Passenger Front Mounting Bracket (**PFM**) to the vehicle using (1) M10X45 Bolt Plate, (1) M10 Lock Washer, (1) M10X1.5 Hex Nut and (1) M10 Large Flat Washer, (**Fig 3**). Attach Passenger Front Support Bracket (**PFS/PRS**) to the vehicle with (1) M10X30 Bolt Plate, (1) M10 Lock Washer, (1) M10X1.5 Hex Nut and (1) M10 Flat Washer, (**Fig 3**). Do not fully tighten hardware at this time.

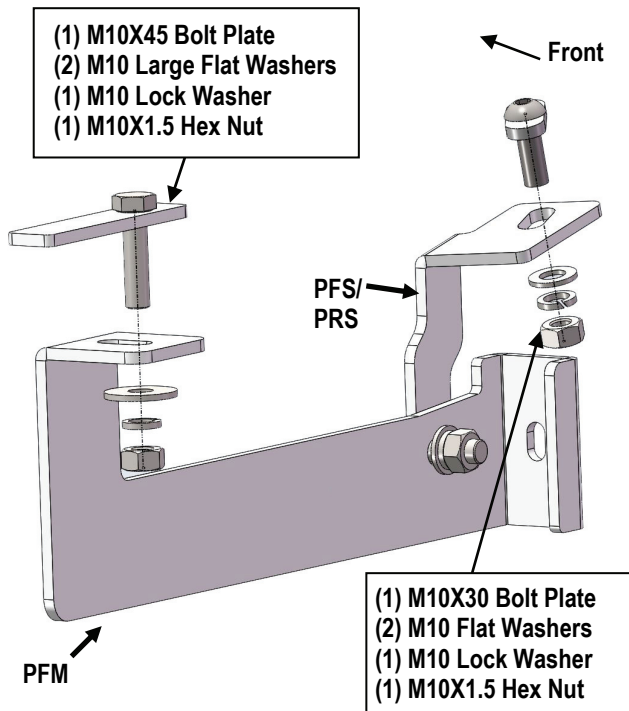

(Fig 3) Passenger Front Mounting Bracket Installation

## STEP 4

Move to passenger rear side, repeat **step 2** for Passenger Rear Mounting Bracket (**PRM**) and Passenger Rear Support Bracket (**PFS/PRS**) assembly.

Next, attach Passenger Rear Mounting Bracket (**PRM**) and Passenger Rear Support Bracket (**PFS/PRS**) with (2) M10X30 Bolt Plate, (2) M10 Lock Washer, (2) M10X1.5 Hex Nut and (4) M10 Flat Washer, (**Fig 4**). Do not tighten hardware at this time.

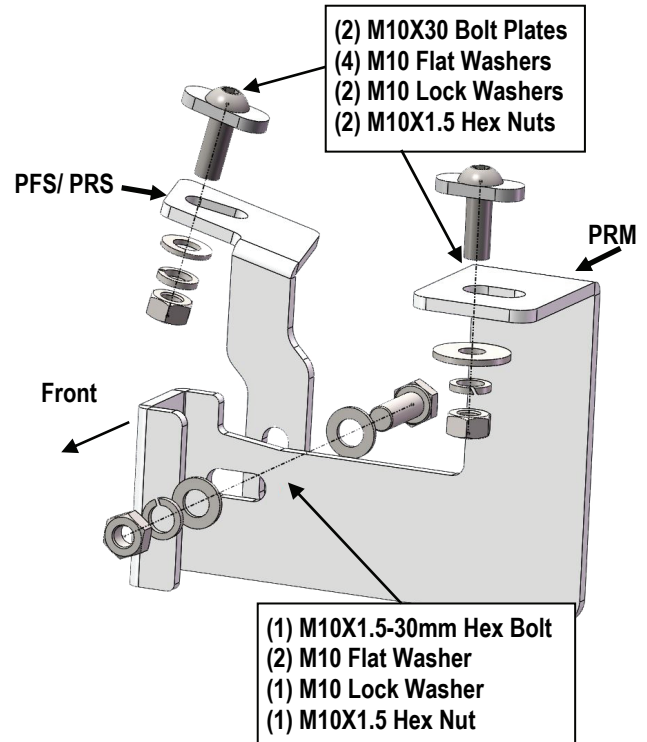

(Fig 4) Passenger Rear Mounting Bracket Installation

## STEP 5

Once all (2) passenger side mounting brackets are installed, select and attach the Passenger Side Step Bar onto the Mounting Brackets with (2) U Brackets, (4) Spacers, (2) M8X1.25-55mm Carriage Bolts, (2) M8 Large Flat Washers, (2) M8 Lock Washers and (2) M8X1.25 Hex Nuts (**Fig 5**). Do not fully tighten hardware at this time.

# iArmor®

**NOTE:** Torque all M8 X1.25-55mm Carriage Bolts to 16~18 lb-ft. Don't over tighten, or the aluminum square bars will be damaged by the brackets

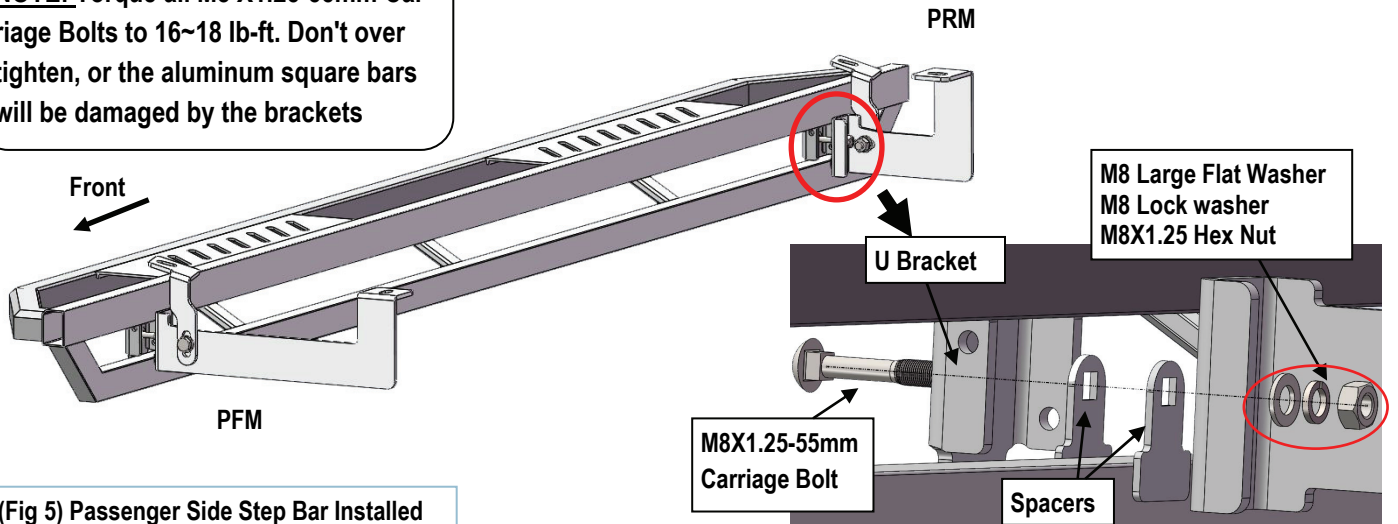

(Fig 5) Passenger Side Step Bar Installed

## STEP 6

Properly level and adjust the Step Bar and fully tighten all hardware.

## STEP 7

Move to the driver side of the vehicle. Repeat **Steps 1-6** to install driver side step bar.

Installation completed (Fig 6).



(Fig 6) Installation Completed

### Attention

Do periodic inspections to the installation to make sure that all hardware is secure and tight.

In order to protect your bars/boards, please use only mild soap/non-abrasive products for cleaning.