

iArmor[®]

IARMOR EDGE™

PART#: IA-N058

BEFORE INSTALLATION

REMOVE CONTENTS FROM BOX. VERIFY ALL PARTS ARE PRESENT. READ INSTRUCTIONS CAREFULLY BEFORE STARTING INSTALLATION. ASSISTANCE IS RECOMMENDED. THANK YOU FOR CHOOSING OUR PRODUCT!

*DRILLING NOT REQUIRED

*TRIMMING NOT REQUIRED

Torque Value

| Fastener Size | Tightening Torque (ft-lbs) | Required |
|---------------|----------------------------|----------|
| 6mm | 6-7 | √ |
| 8mm | 16-18 | √ |
| 10mm | 31-32 | X |
| 12mm | 56-58 | X |
| 14mm | 92-94 | X |

PART LIST

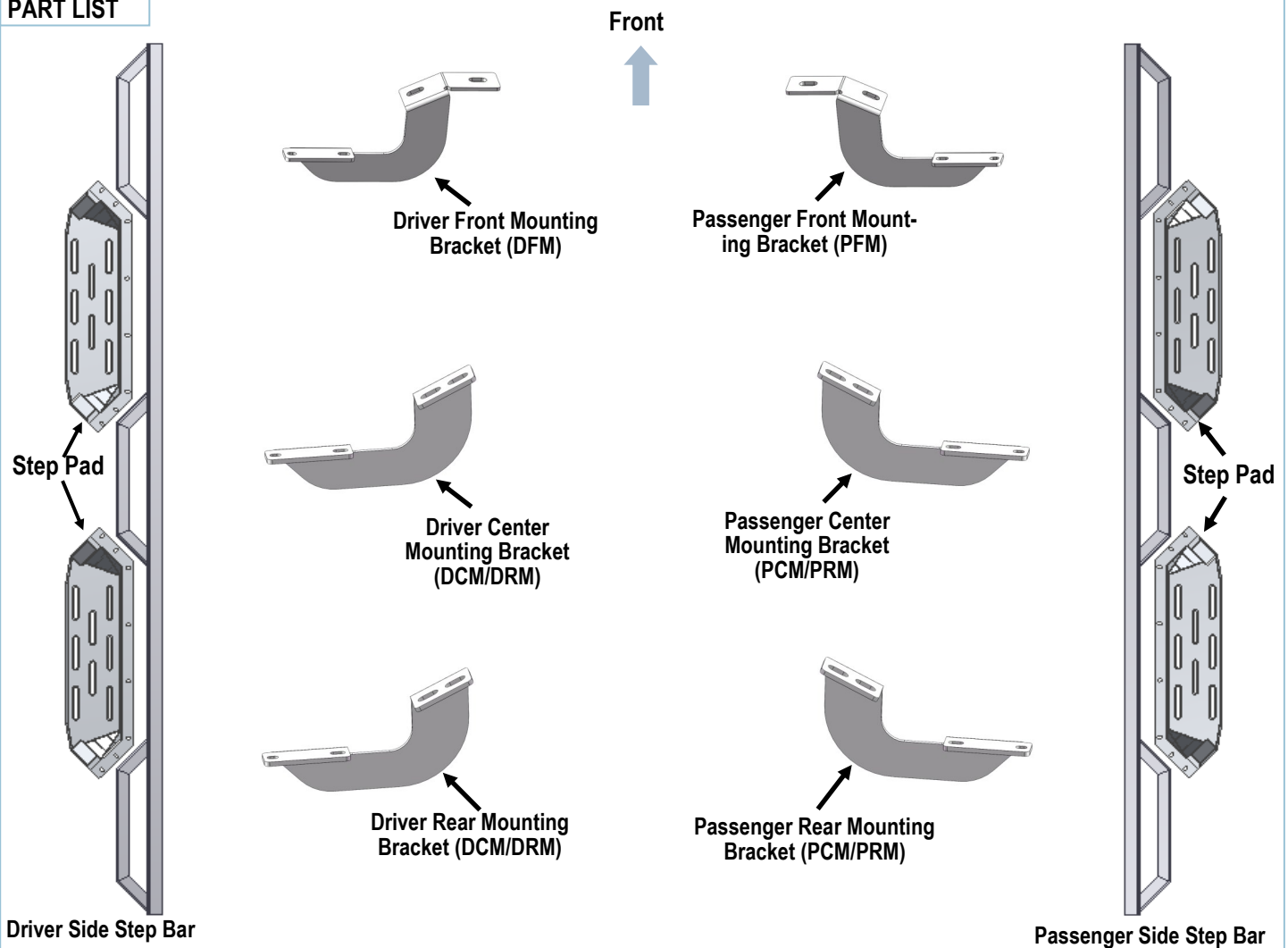

Customer Support: info@iarmorauto.com

iArmor®

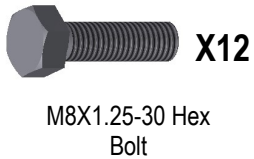

The instruction here is for your reference only. We strongly recommend the professional installer for best result. We are not responsible for any damage caused by the installation.

STEP 1

Install the Step Pads onto the step bars with (32) M6X1-20mm T-Bolts, (32) M6 Large Flat Washers and (32) M6 Nylon Lock Nuts.

IMPORTANT: Don't hit the step pad by any metal hammer within step pad installation, or the step pad will be damaged.

(8) M6X1-20 T-Bolts
(8) M6 Flat Washers
(8) M6 Nylon Lock Nuts

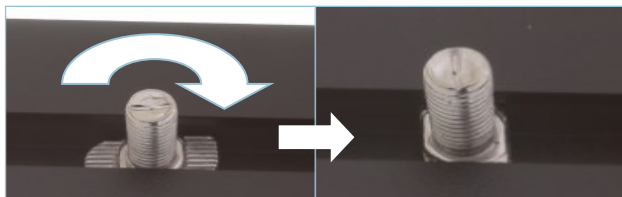

Note: Rotate 90° after inserting the T-Bolts into the Channel!!!

STEP 2

Starting on the driver side front of the vehicle, remove the existing (2) factory bolts, (or plastic plugs), (**Fig 1**). This will be the mounting location for the Driver Front Mounting Bracket.

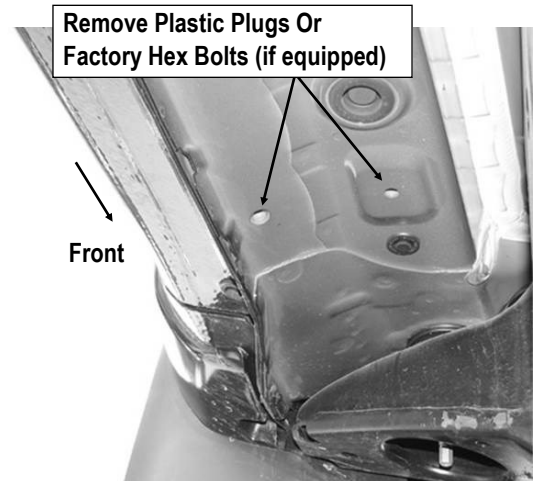

(Fig 1) Driver Side Front Mounting Location

STEP 3

Select the Driver Front Mounting Bracket (**DFM**), (**Fig 2**). Attach the Bracket to the vehicle using the included (2) M8X1.25-30 Hex Bolts, (2) M8 Lock Washers and (2) M8 Flat Washers, (**Fig 3**). Do not fully tighten hardware at this time.

iArmor®

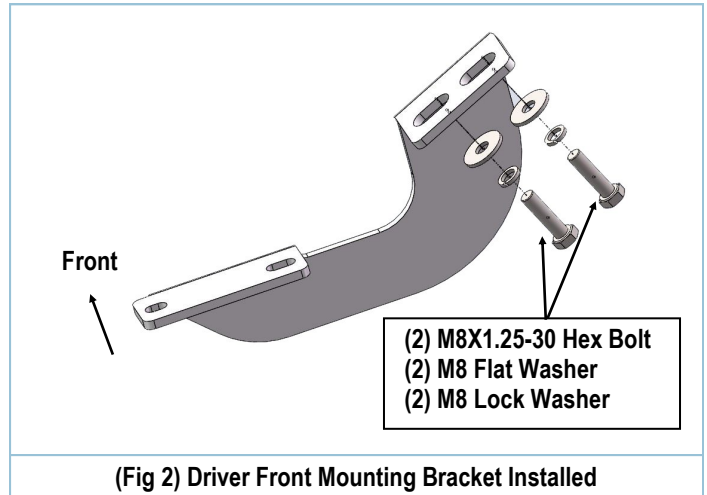
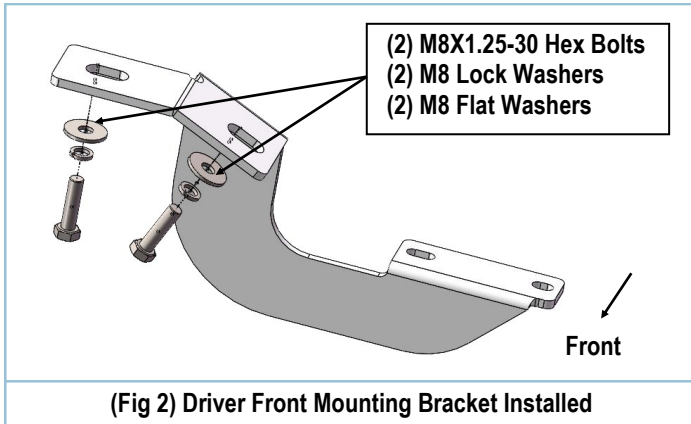

STEP 4

Move along the side panel to the Driver Side Center and Rear Mounting Locations, (Fig 3). Repeat **Steps 2—3** to install the Driver Center & Rear Mounting Brackets (DCM/DRM), (Fig 4).



STEP 6

Properly level and adjust the Step Bar and fully tighten all hardware.

Move to the passenger side of the vehicle. Repeat **Steps 2-5** for the Passenger Side Step Bar installation.

STEP 5

Once all (3) Brackets have been installed, attach the assembled Passenger Side Step Bar onto the brackets with (6) M6X1-20 T-Bolts, (6) M6 Large Flat Washers and (6) M6 Nylon Lock Nuts, (Fig 5). Do not fully tighten hardware at this time.

Attention

Do periodic inspections to the installation to make sure that all hardware is secure and tight.

In order to protect your bars/boards, please use only mild soap/non-abrasive products for cleaning.

iArmor[®]

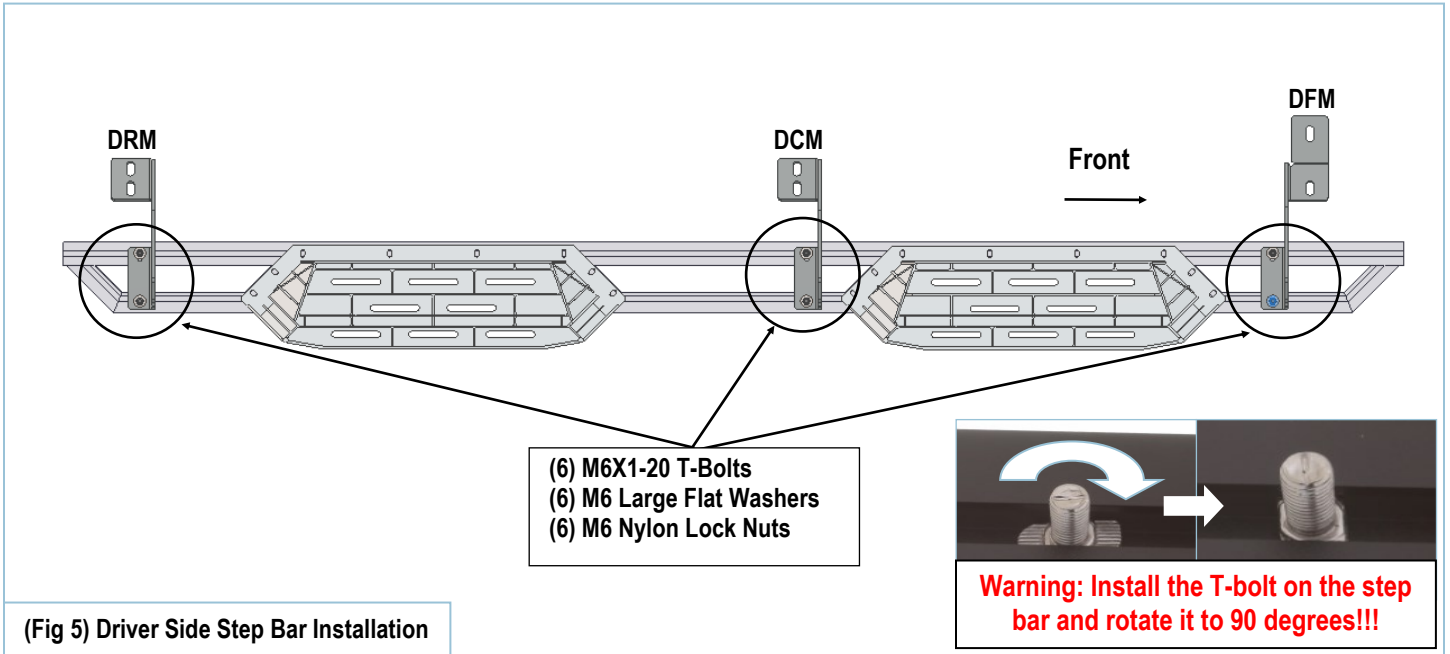

(Fig 5) Driver Side Step Bar Installation