

IARMOR EDGE™

PART#: IA-N054

BEFORE INSTALLATION

REMOVE CONTENTS FROM BOX. VERIFY ALL PARTS ARE PRESENT. READ INSTRUCTIONS CAREFULLY BEFORE STARTING INSTALLATION. ASSISTANCE IS RECOMMENDED. THANK YOU FOR CHOOSING OUR PRODUCT!

*DRILLING IS REQUIRED

*TRIMMING NOT REQUIRED

Torque Value

Fastener Size	Tightening Torque (ft-lbs)	Required
6mm	6-7	√
8mm	16-18	√
10mm	31-32	X
12mm	56-58	X
14mm	92-94	X

PART LIST

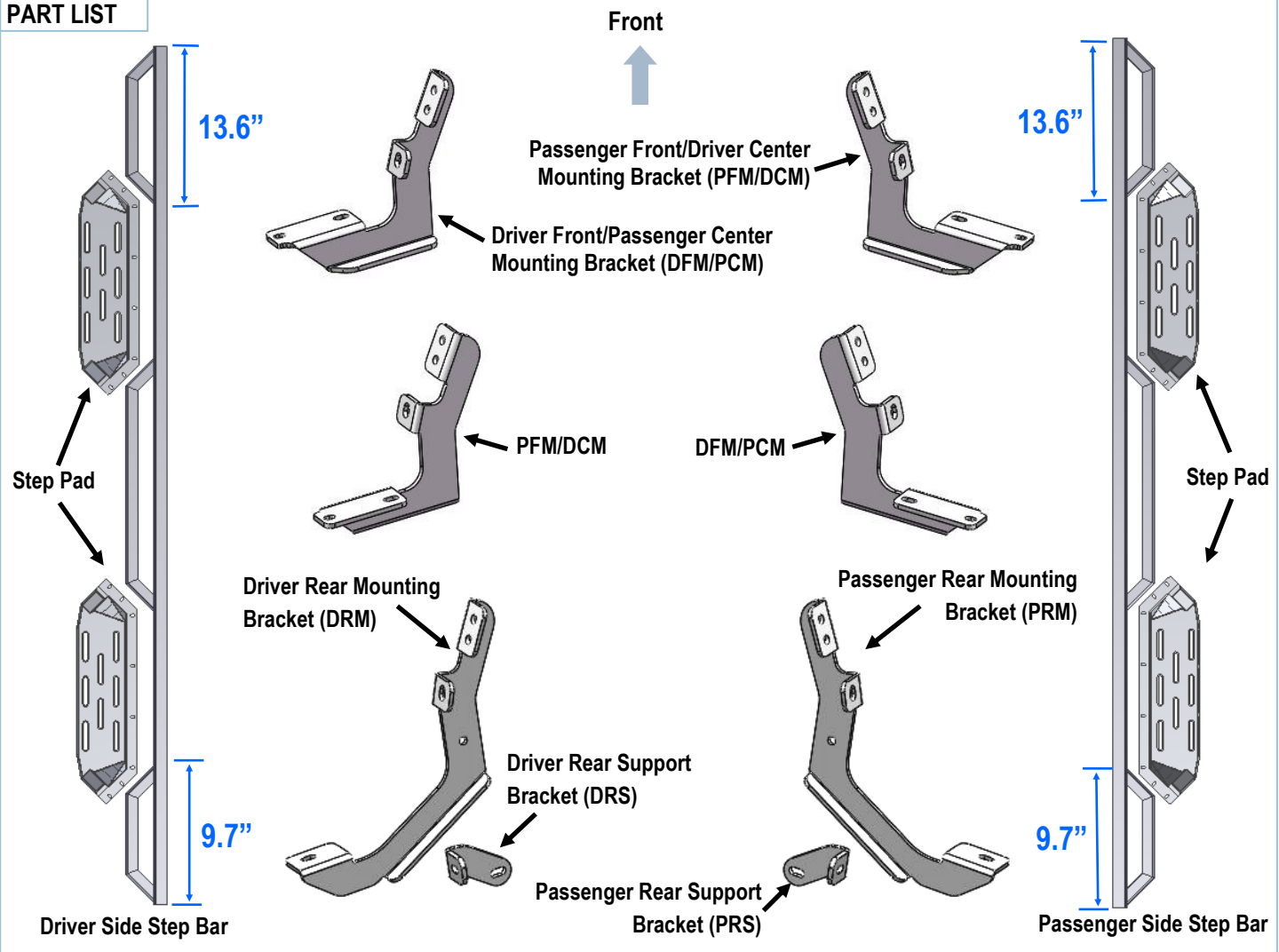

Customer Support: info@iarmorauto.com

iArmor®

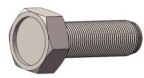

X12

ST6.3-25 Hex Self Tapping
Screws

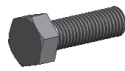

X2

M8X1.25-25mm
Hex Bolt

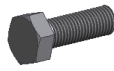

X6

M8X1.25-20mm
Hex Bolt



X16

M8 Large Flat
Washer



X8

M8X1.25 Nylon
Lock Nut



X40

M6X1-20mm T
- Bolt



X4

M6X1-20mm
Square Head Bolt



X44

M6 Large Flat
Washer



X44

M6X1 Nylon
Lock Nut

The instruction here is for your reference only. We strongly recommend the professional installer for best result. We are not responsible for any damage caused by the installation.

STEP 1

Install the Step Pads onto the step bars with (32) M6X1-20mm T-Bolts, (32) M6 Large Flat Washers and (32) M6X1 Nylon Lock Nuts.

IMPORTANT: Don't hit the step pad by any metal hammer within step pad installation, or the step pad will be damaged.

(8) M6x1-20mm T-Bolts
(8) M6 Large Flat Washers
(8) M6X1 Nylon Lock Nuts

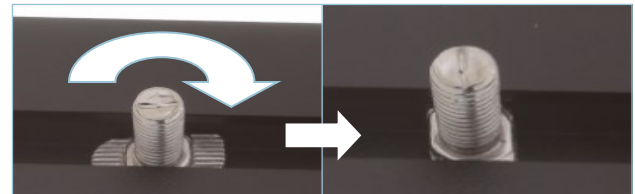

Note: Rotate 90° after inserting the T-Bolts into the Channel!!!

STEP 2

Start the installation from the driver side of the vehicle, drill (3) 8mm holes in pinch weld as shown (**Fig 1**).

STEP 3

Select (1) Driver Front Mounting Bracket (**DFM/PCM**), attach the Mounting Bracket to the drilled holes on driver side front mounting location with (2) ST6.3-25 Hex Self Tapping Screws, (1) M8X1.25-20mm Hex Bolts, (2) M8 Large Flat Washers and (1) M8X1.25 Nylon Lock Nut, (**Fig 2**). Do not fully tighten at this time.

iArmor®

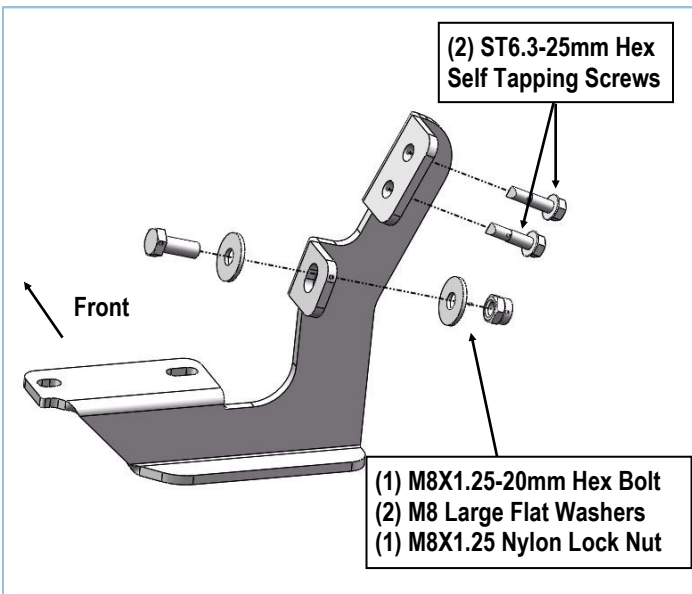
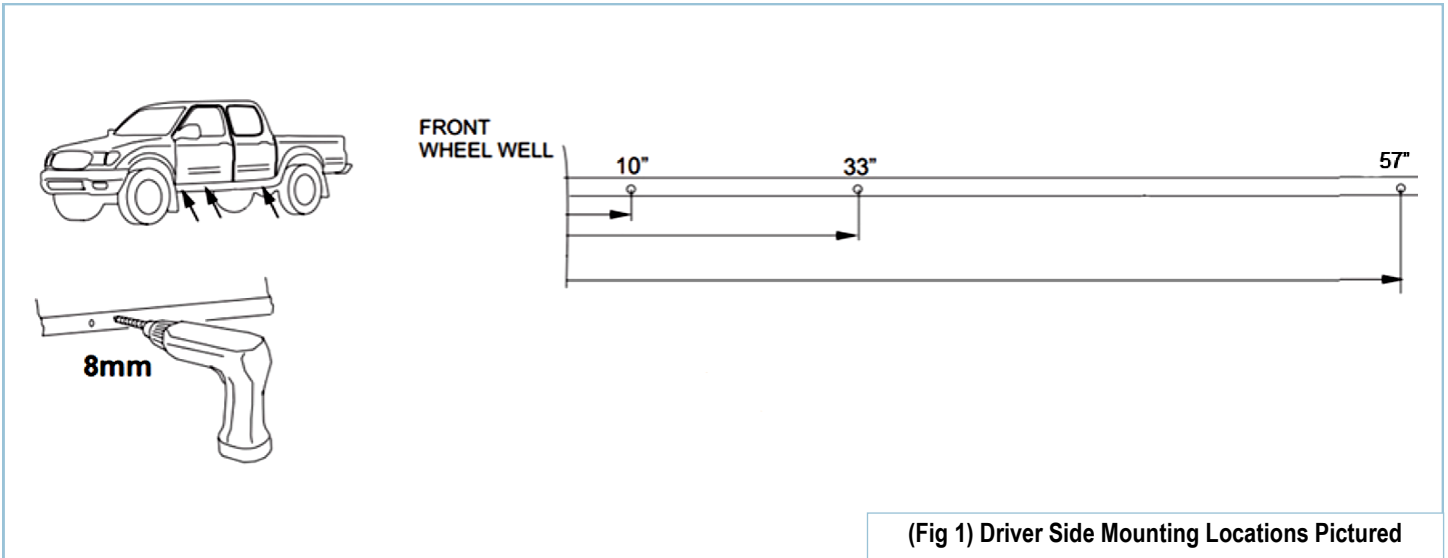

(Fig 2) Driver Front Mounting Bracket Installation

STEP 4

Repeat **Steps 2-3** for the Driver Center Mounting Bracket (PFM/DCM) installation. Do not fully tighten hardware at this time.

STEP 5

Select (1) Driver Rear Mounting Bracket (DRM) and (1) Driver Rear Support Bracket (DRS), assembly with (1) M8X1.25-25mm Hex Bolts, (2) M8 Large Flat Washers and (1) M8X1.25 Nylon Lock Nut, (Fig 3). Do not fully tighten at this time.

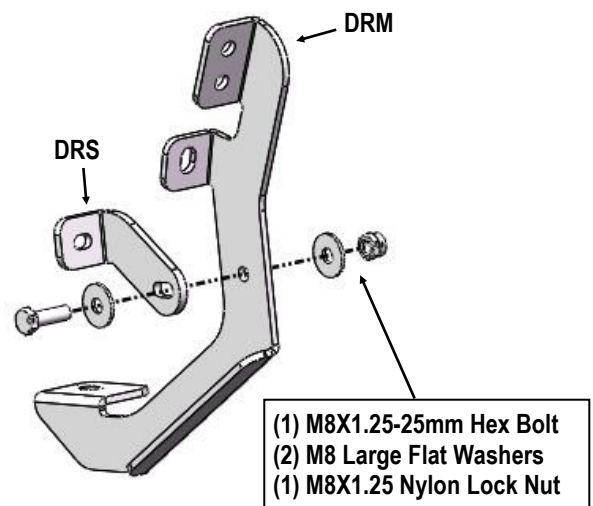

(Fig 3) Driver Side Rear Brackets Assembly

iArmor[®]

STEP 6

Next, repeat **Step 3** to attach the Assembled Driver Rear Bracket to the vehicle. Do not fully tighten at this time.

STEP 7

Once all (3) driver side mounting brackets are installed, attach the Assembled Driver Side Step Bar onto the brackets with (4) M6X1-20mm T-Bolts, (2) M6X1-20mm Square Head Bolts, (6) M6 Large Flat Washers and (6) M6x1 Nylon Lock Nuts, (**Fig 4**). Do not fully tighten hardware at this time. Properly level and adjust the Step Bar and fully tighten all hardware.

STEP 8

Move to the passenger side of the vehicle. Repeat **Steps 2-7** to install passenger side step bar.

Attention

Do periodic inspections to the installation to make sure that all hardware is secure and tight.

In order to protect your bars/boards, please use only mild soap/non-abrasive products for cleaning.

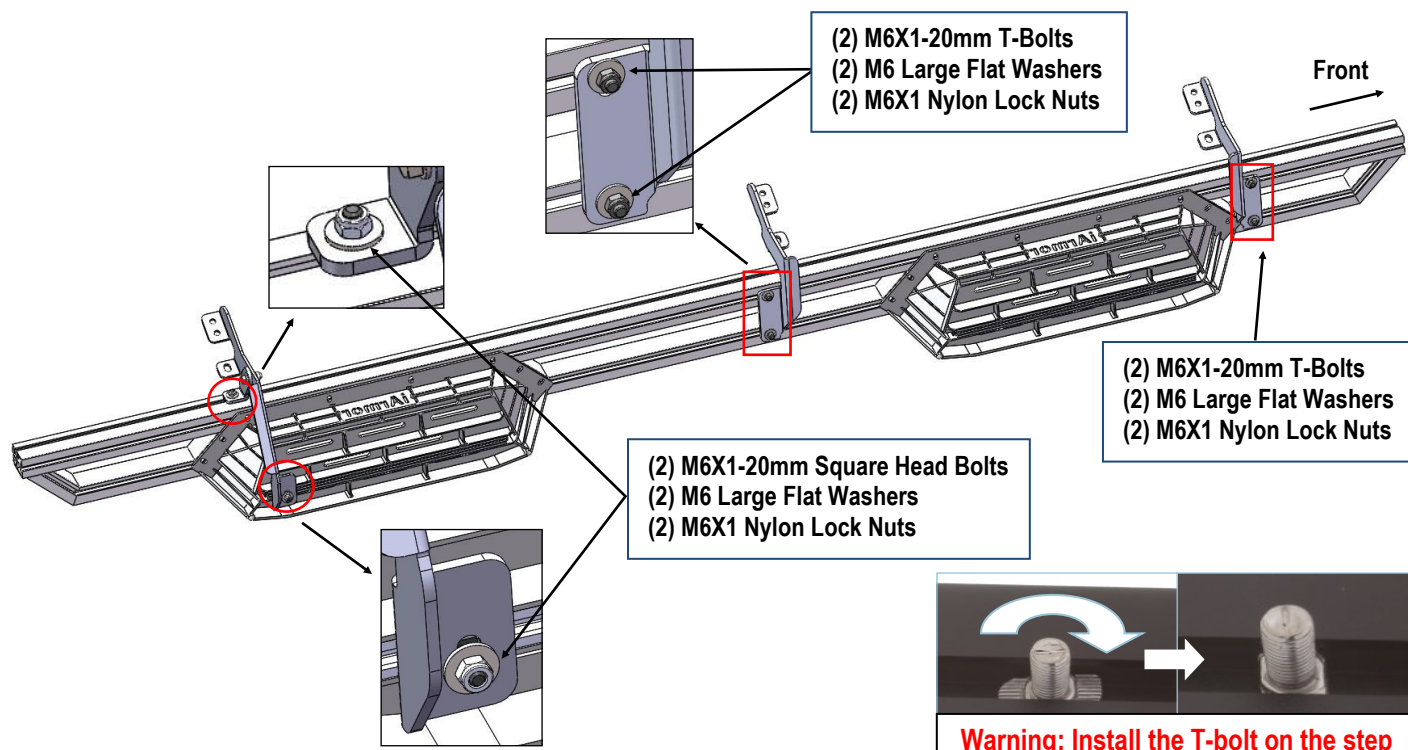

(Fig 4) Driver Side Step Bar Installed