

IARMOR EDGE™

PART#: IA-N936

BEFORE INSTALLATION

REMOVE CONTENTS FROM BOX. VERIFY ALL PARTS ARE PRESENT. READ INSTRUCTIONS CAREFULLY BEFORE STARTING INSTALLATION. ASSISTANCE IS RECOMMENDED. THANK YOU FOR CHOOSING OUR PRODUCT!

*DRILLING NOT REQUIRED

*TRIMMING NOT REQUIRED

Torque Value





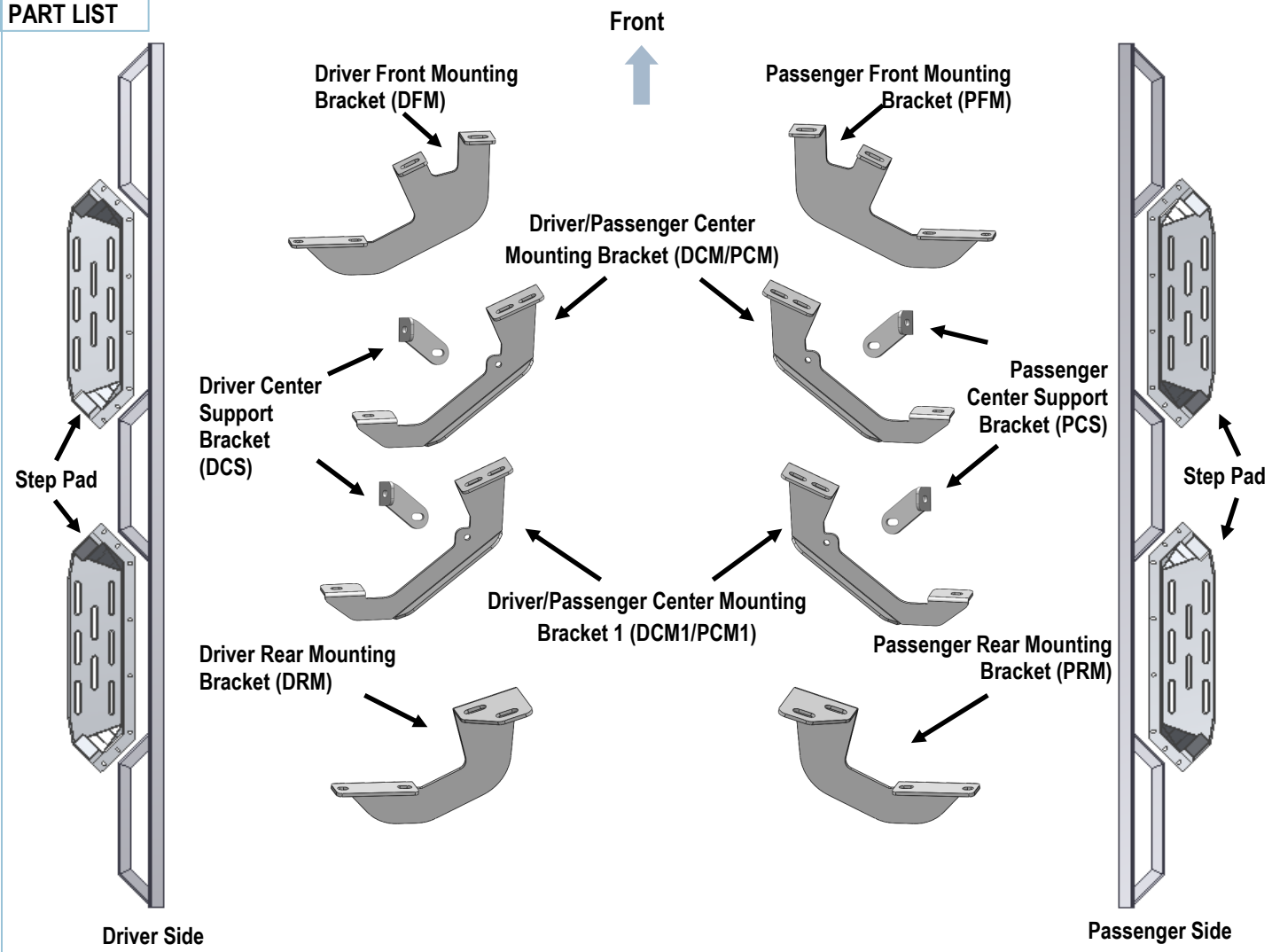

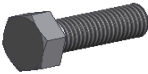
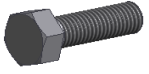

Fastener Size	Tightening Torque (ft-lbs)	Required
6mm	6-7	√
8mm	16-18	√
10mm	31-32	X
12mm	56-58	X
14mm	92-94	X

PART LIST

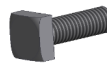

iArmor[®]

Hardware Package					
Item	QTY	Description	Item	QTY	Description
1#	16	M8X1.25-30mm Hex Bolts	6#	8	M6X1-20mm Square Head Bolts
2#	4	M8X1.25-25mm Hex Bolts	7#	40	M6X1-20mm T-Bolts
3#	24	M8 Large Flat Washers	8#	48	M6 Large Flat Washers
4#	20	M8 Lock Washers	9#	48	M6 Nylon Lock Nuts
5#	4	M8 Hex Nuts			

								
1#	2#	3#	4#	5#	6#	7#	8#	9#

iArmor[®]

The instruction here is for your reference only. We strongly recommend the professional installer for best result. We are not responsible for any damage caused by the installation.

STEP 1

Install the Step Pads onto the step bars with (32) M6X1-20mm T-Bolts, (32) M6 Large Flat Washers and (32) M6 Nylon Lock Nuts.

IMPORTANT: Don't hit the step pad by any metal hammer within step pad installation, or the step pad will be damaged.

(8) M6X1-20 T-Bolts
(8) M6 Flat Washers
(8) M6 Nylon Lock Nuts



Note: Rotate 90° after inserting the T-Bolts into the Channel!!!

STEP 2

Start installation from the driver side of the vehicle. Identify the Driver Side Mounting Locations along the inner side of the rocker panel, (Fig 1). (2) factory threaded holes on each location.

STEP 3

Attach the driver side front mounting bracket (DFM) onto the mounting locations with (2) M8X1.25-30mm Hex Bolt, (2) M8 Lock Washers and (2) M8 Large Flat Washers for each mounting bracket, (Fig 2).

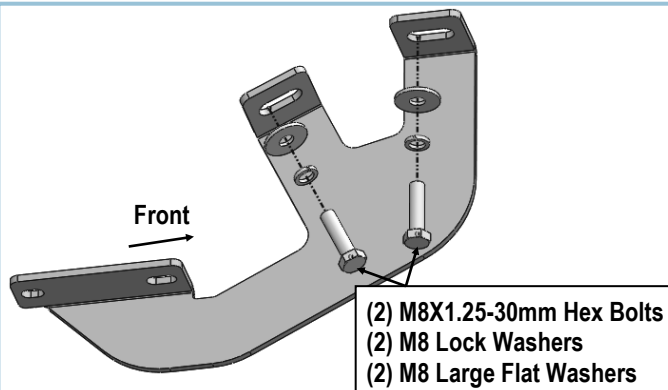

(Fig 2) Driver Front Mounting Bracket (DFM) Installation

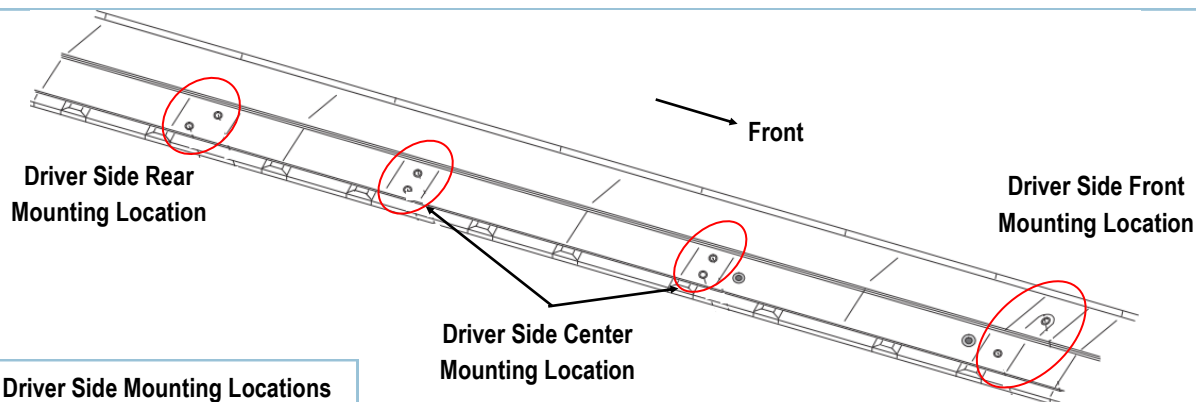

(Fig 1) Driver Side Mounting Locations

STEP 4

Assemble Driver Center Mounting Bracket (**DCM**) and Driver Center Support Bracket (**DCS**) with (1) M8X1.25-25mm Hex Bolt, (2) M8 Large Flat Washers, (1) M8 Lock Washer and (1) M8 Hex Nut, (**Fig 3**). Assemble **DCM1** and **DCS1** in the same way. Do not fully tighten hardware at this time.

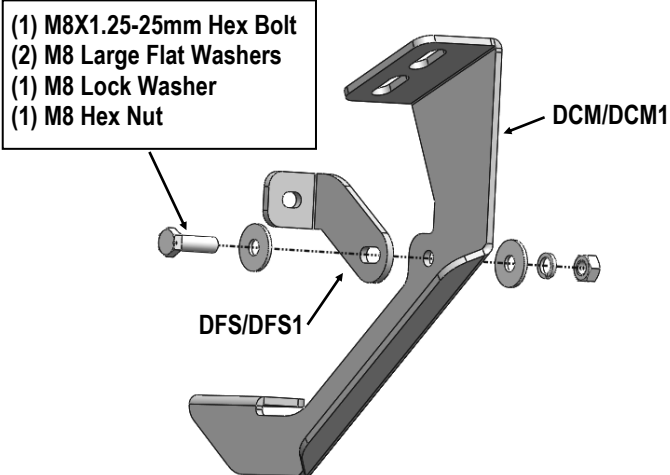

(Fig 3) Driver Center Mounting Brackets Assembly

STEP 5

Attach Driver Side (2) Center Mounting Brackets (**DCM/DCM1**) and (1) Rear Mounting Brackets (**DRM**) onto the mounting locations with (2) M8X1.25-30mm Hex Bolts, (2) M8 Lock Washers and (2) M8 Large Flat Washers for each mounting bracket, (**Fig 4 & Fig 5**). Do not fully tighten hardware at this time.

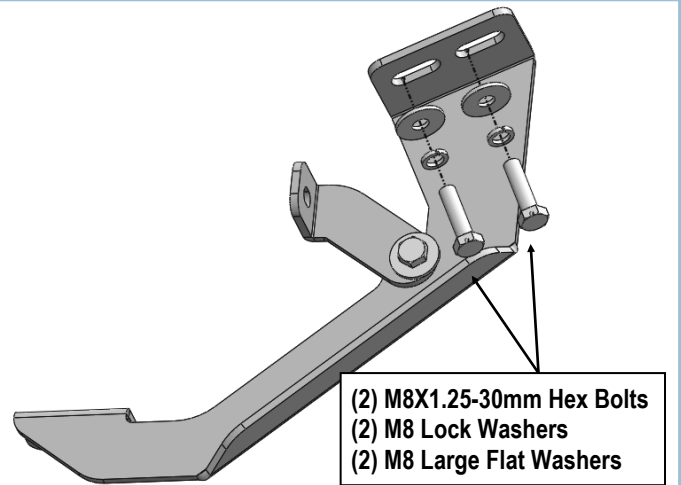

(Fig 4) Driver Center Mounting Brackets (DCM/DCM1) Installation

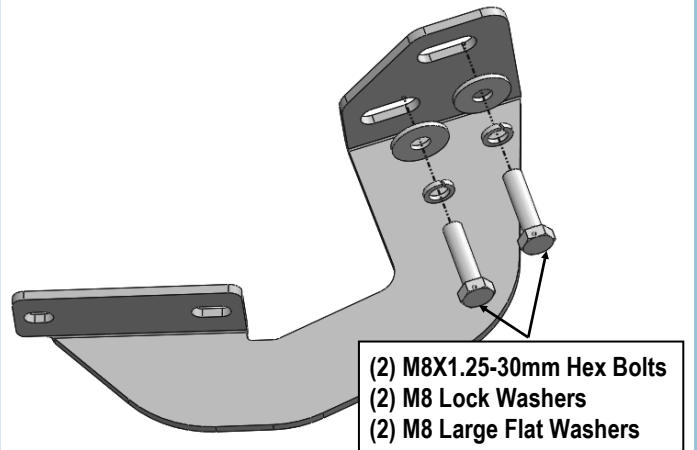

(Fig 5) Driver Rear Mounting Bracket (DRM) Installation

STEP 6

Once all (4) Driver side mounting brackets are installed, select and attach the assembled Passenger Side Step Bar onto the Mounting Brackets with (4) M6X1-20mm Square Head Bolts, (4) M6X1-20mm T-Bolts, (8) M6 Large Flat Washers and (8) M6 Nylon Lock Nuts, (**Fig 6**). Do not fully tighten hardware at this time.

iArmor®

(Fig 6) Passenger Side Step Bar Installation

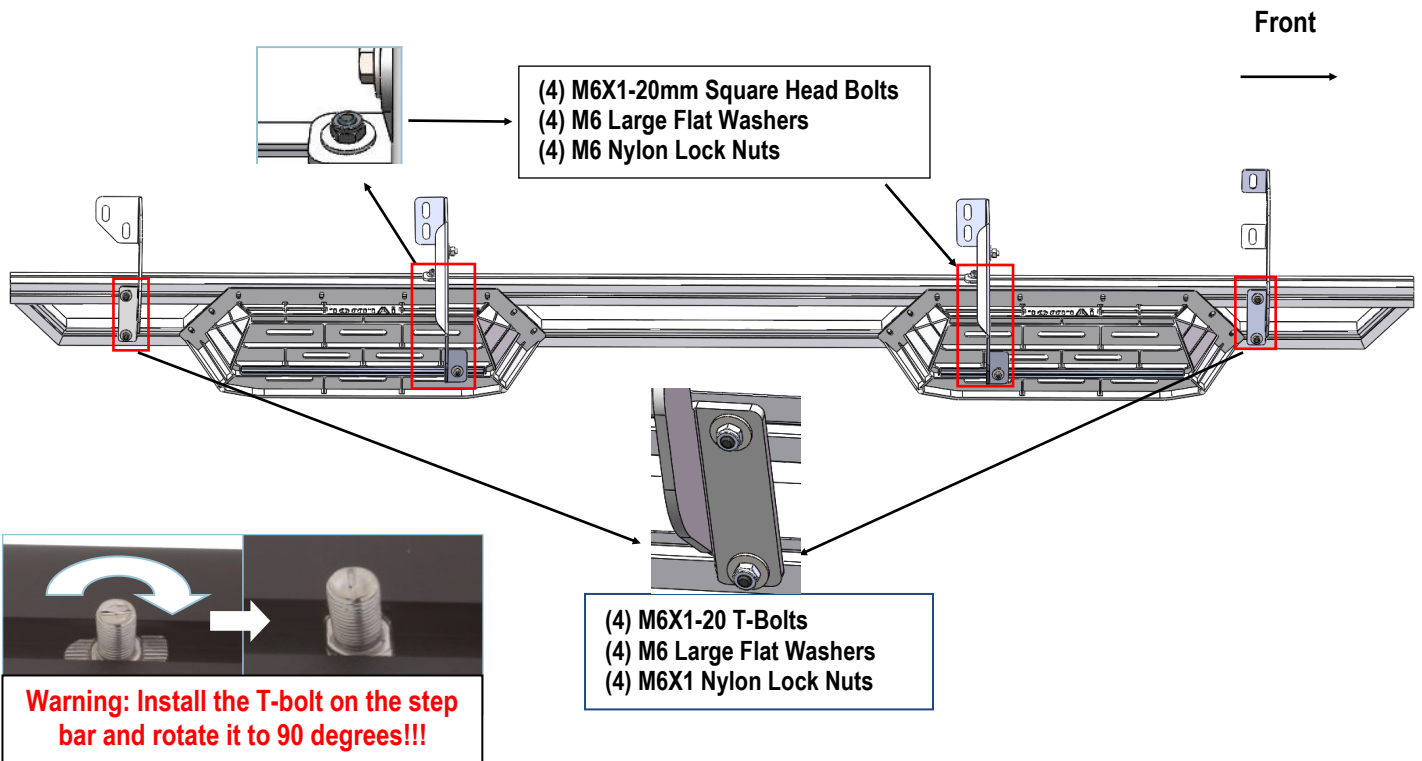

STEP 7

Properly level and adjust the Step Bar and fully tighten all hardware.

STEP 8

Move to the Driver side of the vehicle. Repeat **Steps 2-7** for the Driver Side Step Bar installation.

Attention

Do periodic inspections to the installation to make sure that all hardware is secure and tight.
In order to protect your bars/boards, please use only mild soap/non-abrasive products for cleaning.