

# iArmor®

## IARMOR EDGE™

PART#: IA-W050

### BEFORE INSTALLATION

REMOVE CONTENTS FROM BOX. VERIFY ALL PARTS ARE PRESENT. READ INSTRUCTIONS CAREFULLY BEFORE STARTING INSTALLATION. ASSISTANCE IS RECOMMENDED. THANK YOU FOR CHOOSING OUR PRODUCT!

\*ROCKER PANEL MOUNT

\*DRILLING / TRIMMING NOT REQUIRED

| Fastener Size | Tightening Torque (ft-lbs) | Required |
|---------------|----------------------------|----------|
| 6mm           | 6-7                        | X        |
| 8mm           | 16-18                      | √        |
| 10mm          | 31-32                      | √        |
| 12mm          | 56-58                      | X        |
| 14mm          | 92-94                      | X        |

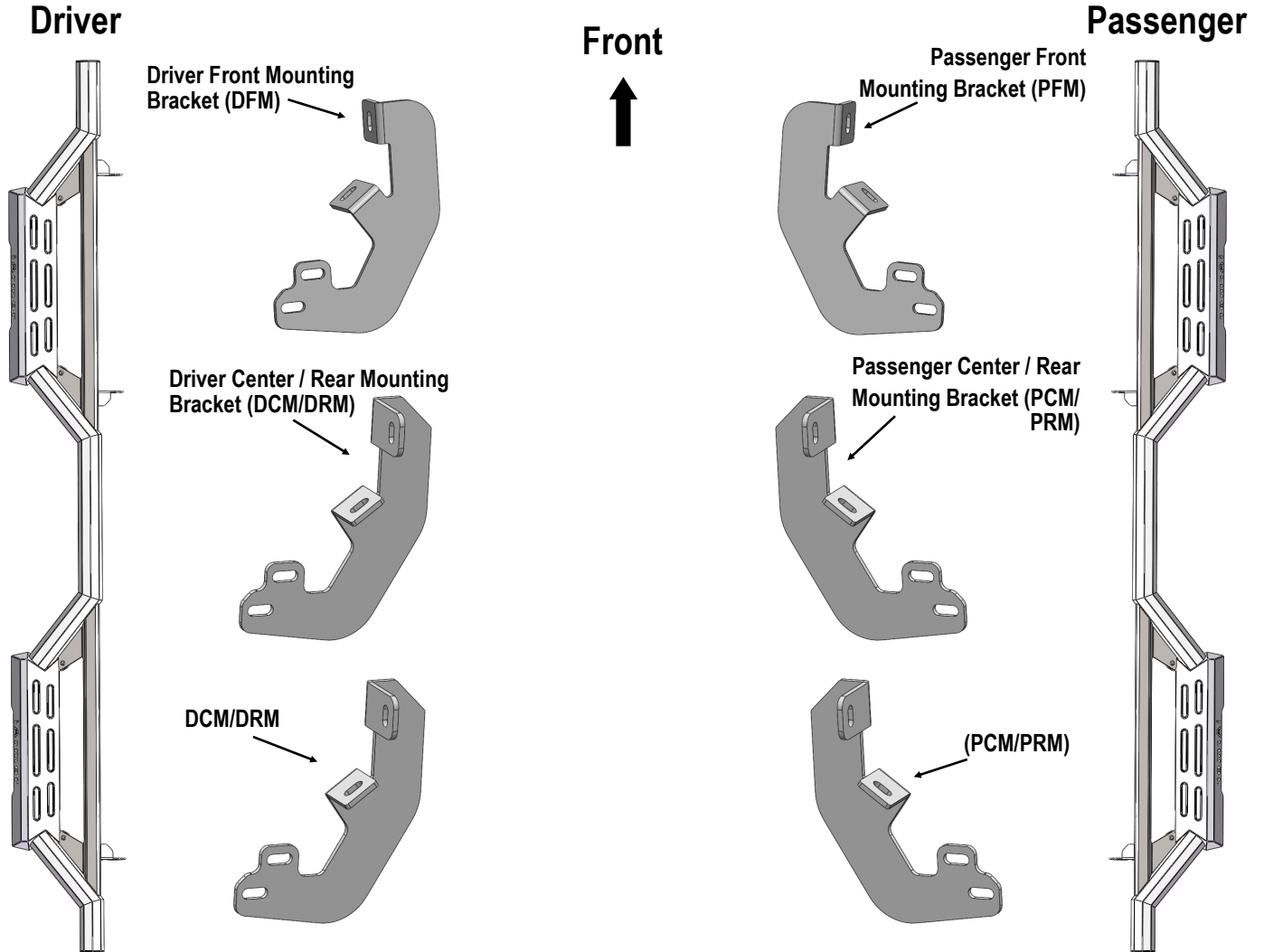

Customer Support: [info@iarmorauto.com](mailto:info@iarmorauto.com)

# iArmor<sup>®</sup>

## Hardware Package (For Brackets & Step Bars Installation)

| Item | QTY | Description             | Item | QTY | Description             |
|------|-----|-------------------------|------|-----|-------------------------|
| 1#   | 12  | M8X1.25-30 Hex Bolts    | 5#   | 12  | M10X1.5-25 Hex Bolts    |
| 2#   | 12  | M8 Large Flat Washers   | 6#   | 24  | M10 Flat Washers        |
| 3#   | 12  | M8 Lock Washers         | 7#   | 12  | M10X1.5 Nylon Lock Nuts |
| 4#   | 6   | M8X1.25 Nylon Lock Nuts |      |     |                         |

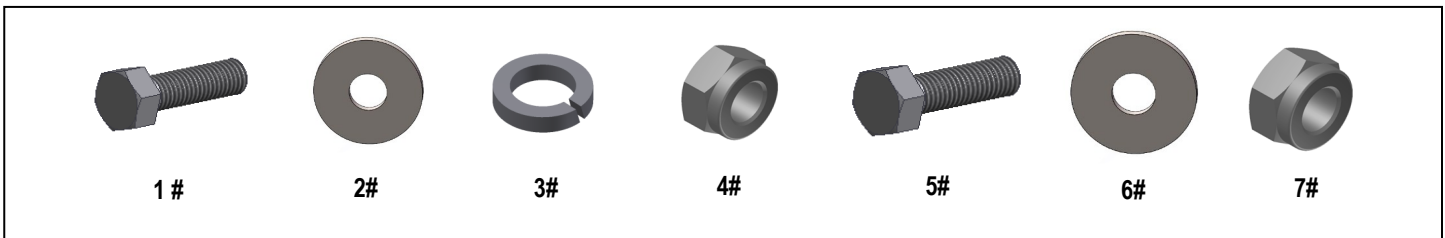

# iArmor®

The instruction here is for your reference only. We strongly recommend the professional installer for best result. We are not responsible for any damage caused by the installation.

## STEP 1

Start installation from the driver side front of the vehicle and locate the factory threaded holes or stud located on the side of the inner body panel, (Figs 1 & 2).

**NOTE:** Remove the plastic plug or any insulation on the side panel to locate the threaded holes.

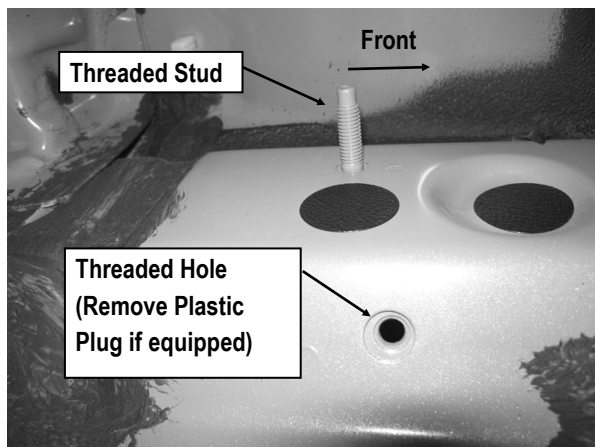

(Fig 1) Driver Side Rear Mounting Location  
(Up to 2015 models)

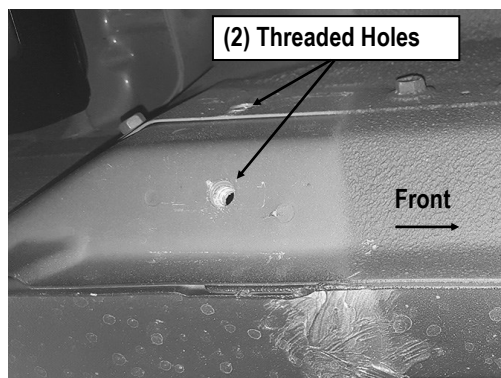

(Fig 2) Driver Side Rear Mounting Location  
(2016-UP models)

## STEP 2

Attach (1) Driver Front Mounting Bracket (DFM) onto the Driver Side Front Mounting Location as shown.

- a. **Models with threaded stud:** Attach the Mounting Bracket to upper stud with (1) Large M8 Flat Washer and (1) M8 Nylon Lock Nut. Next, secure the bracket to the lower threaded hole with (1) M8X1.25-30 Hex Bolt, (1) M8 Large Flat Washer and (1) M8 Lock Washer (Fig 3). Do not tighten hardware at this time.
- b. **Models without threaded stud:** Attach the Mounting Bracket to the upper threaded hole with (1) M8X1.25-30 Hex Bolt, (1) M8 Large Flat Washer and (1) M8 Lock Washer. Next, secure the bracket to the lower threaded hole with (1) M8X1.25-30 Hex Bolt, (1) M8 Large Flat Washer and (1) M8 Lock Washer (Fig 4). Do not fully tighten hardware at this time.

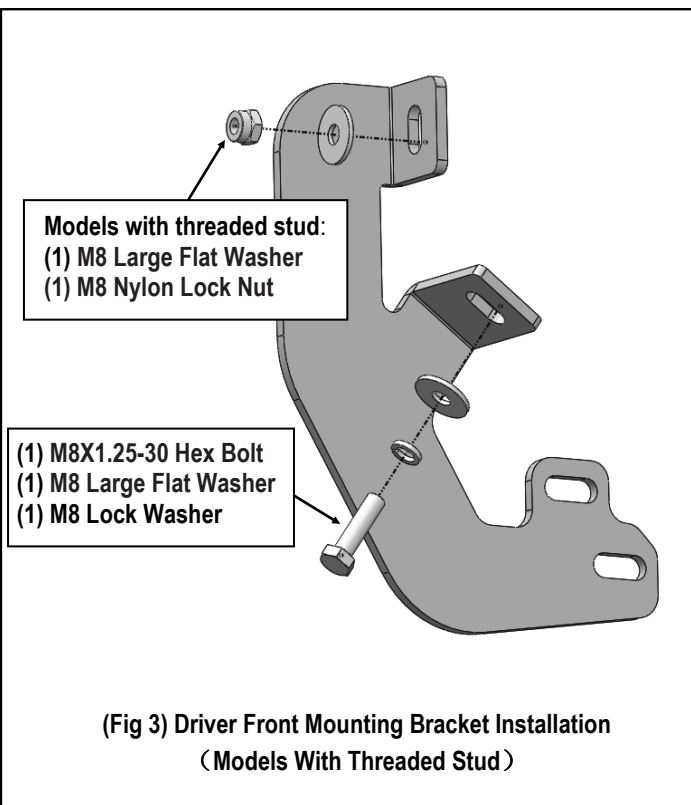

(Fig 3) Driver Front Mounting Bracket Installation  
(Models With Threaded Stud)

# iArmor®

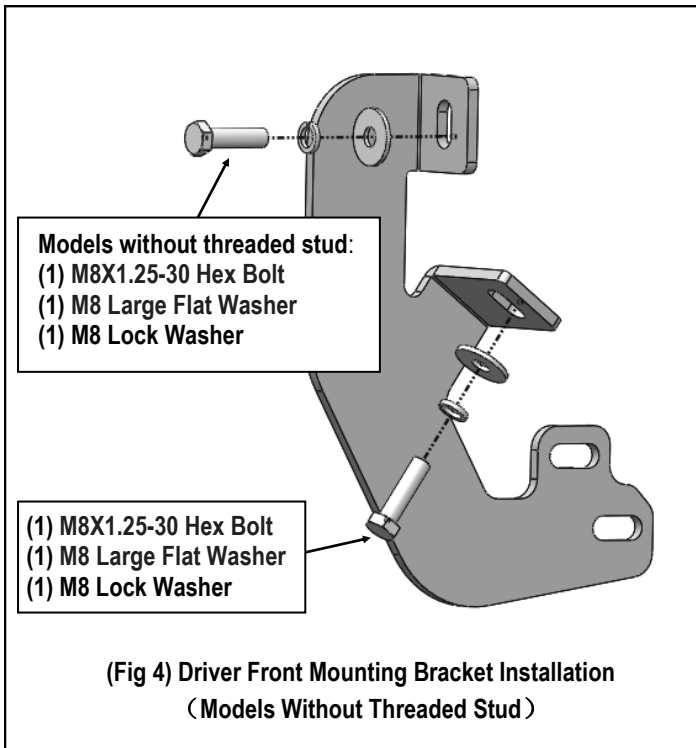

## STEP 3

Move to Driver Side Center and Rear Mounting Location. Repeat **Steps 1-2** to install the Driver Center and Rear Mounting Brackets (DCM/DRM). Do not fully tighten hardware at this time.

## STEP 4

Once all (3) Driver Side Mounting Brackets have been installed, attach the Driver Side Step Bar to the Mounting Brackets with (6) M10X1.5-25 Hex Bolts, (12) M10 Flat Washers and (6) M10X1.5 Nylon Lock Nuts, (Fig 5). Properly level and adjust the Step Bar and fully tighten all hardware.

## STEP 5

Move to the other side of the vehicle. Repeat **Steps 1-4** to install the other side step bar.

### Attention

Do periodic inspections to the installation to make sure that all hardware is secure and tight.

In order to protect your bars/boards, please use mild soap/non-abrasive products for cleaning only.

