

iArmor®

IARMOR EDGE™

PART#: IA-W972

BEFORE INSTALLATION

REMOVE CONTENTS FROM BOX. VERIFY ALL PARTS ARE PRESENT. READ INSTRUCTIONS CAREFULLY BEFORE STARTING INSTALLATION. ASSISTANCE IS RECOMMENDED. THANK YOU FOR CHOOSING OUR PRODUCT!

*ROCKER PANEL MOUNT

*DRILLING/TRIMMING NOT REQUIRED

Torque Value

Fastener Size	Tightening Torque (ft-lbs)	Required
6mm	6-7	X
8mm	16-18	X
10mm	31-32	√
12mm	56-58	X
14mm	92-94	X

PART LIST

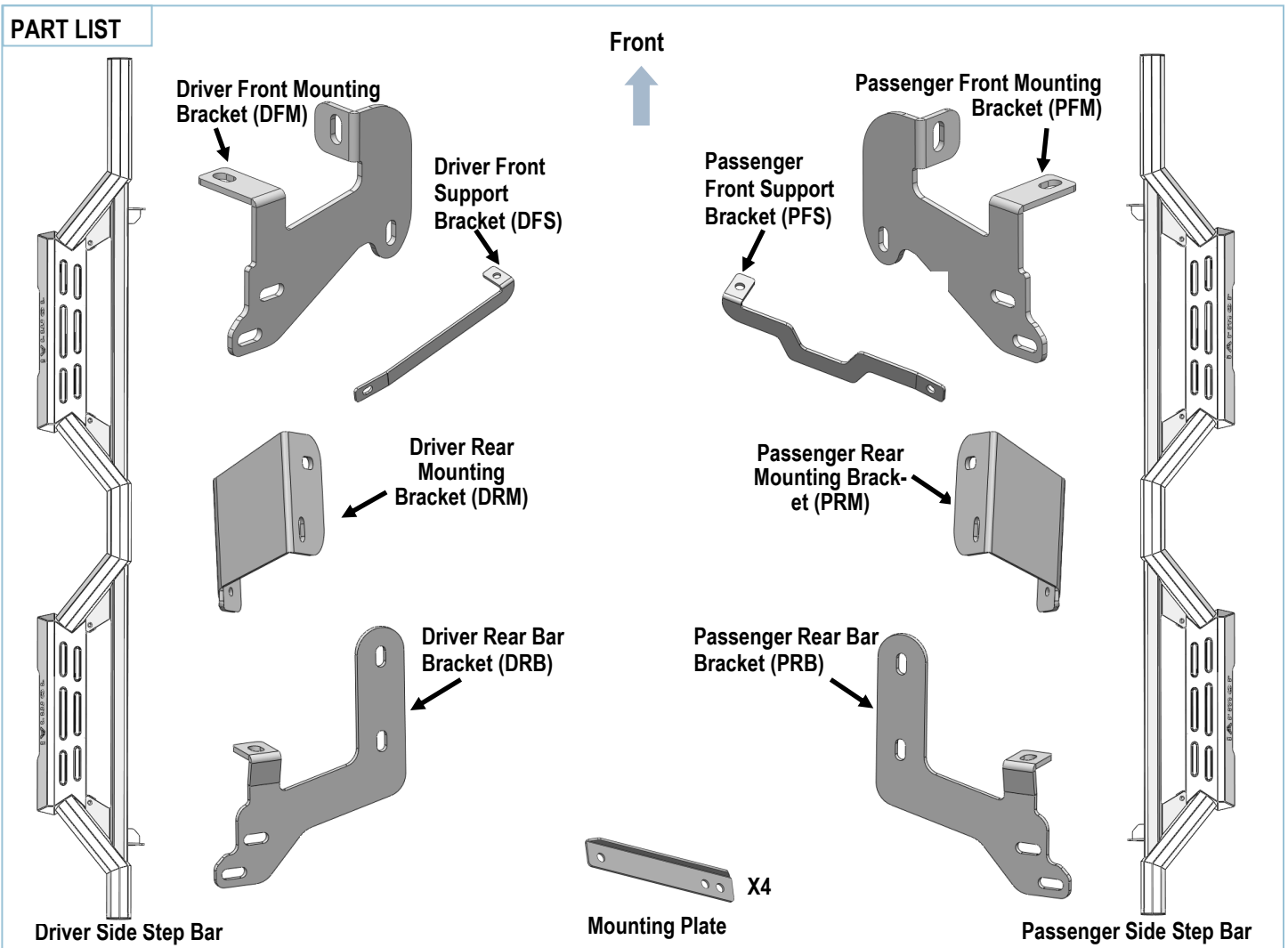

Customer Support: info@iarmorauto.com

iArmor[®]

Hardware Package (For Brackets & Step Bars Installation)					
Item	QTY	Description	Item	QTY	Description
1#	2	M10X40 Double Bolt Plates	8#	12	M8 Large Flat Washers
2#	12	M10X35 Bolt Plates	9#	6	M8 Lock Washers
3#	14	M10 Plastic Washers	10#	6	M8 Hex Nuts
4#	16	M10 Large Flat Washers	11#	8	M10X1.5-25 Hex Bolts
5#	16	M10 Lock Washers	12#	16	M10 Flat Washers
6#	16	M10 Hex Nuts	13#	8	M10X1.5 Nylon Lock Nuts
7#	6	M8X1.25-30 Hex Bolts			

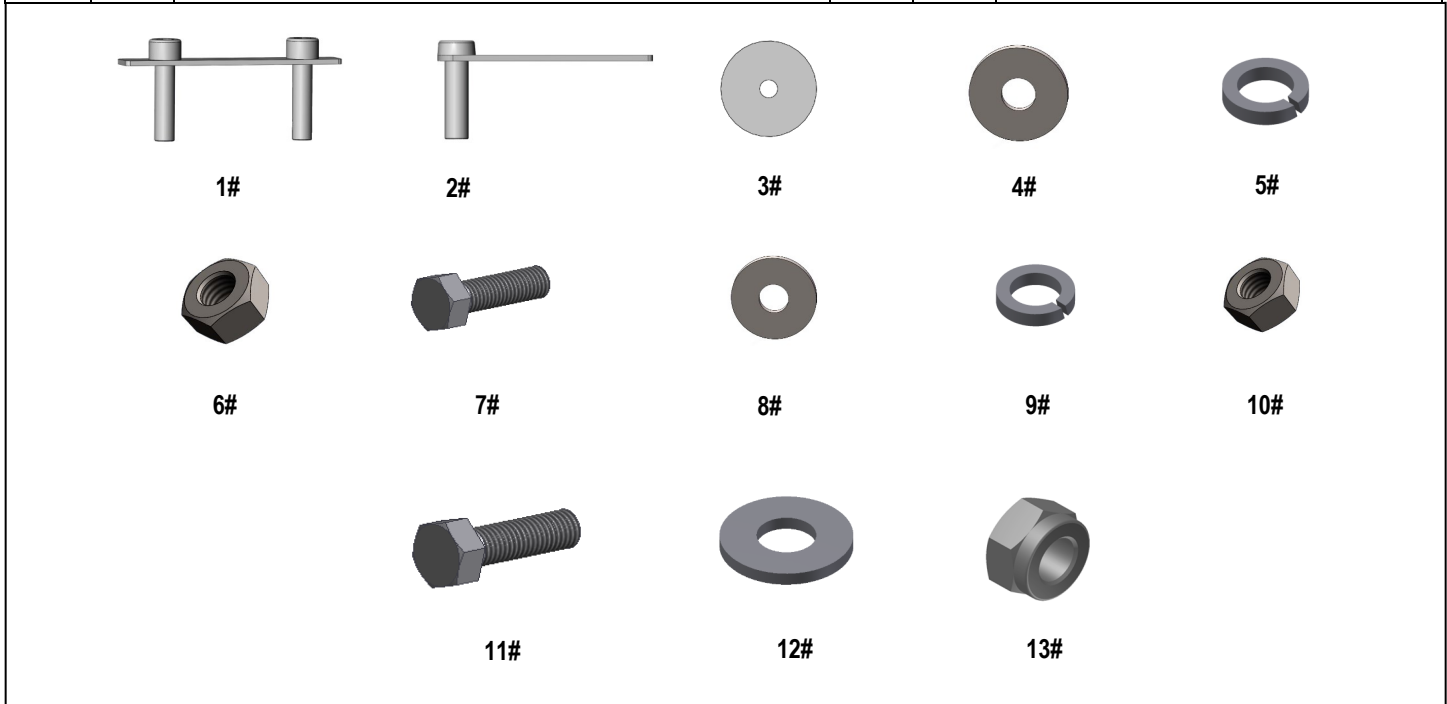

iArmor®

The instruction here is for your reference only. We strongly recommend the professional installer for best result. We are not responsible for any damage caused by the installation.

STEP 1

Start the installation under the passenger side front of the vehicle. Locate and remove the (3) rubber plugs at the bottom of the outer frame channel closest to the front wheel opening, (Fig 1).

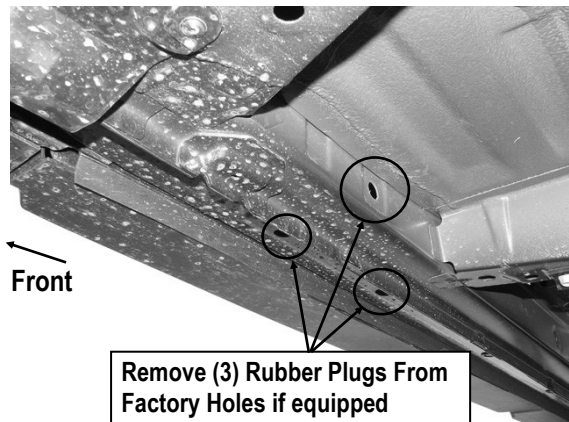

(Fig 1) Passenger Side Front Mounting Location

STEP 2

Select (2) M10X35 Bolt Plates and (2) M10 Plastic Washers. Partially thread the M10 Plastic Washer onto the Bolt Plate, **NOTE:** The Plastic Washer is designed to hold the Bolt Plate in place during Bracket installation.

Insert (1) M10X35 Bolt Plate into the most front hole with the plate pointed toward the rear of the vehicle, (Fig 2). Thread the M10 Plastic Washer down tight against the body panel. Repeat to install the other M10X35 Bolt Plate into the other hole with the Mounting Plate pointed toward the front of the vehicle, (Fig 3).

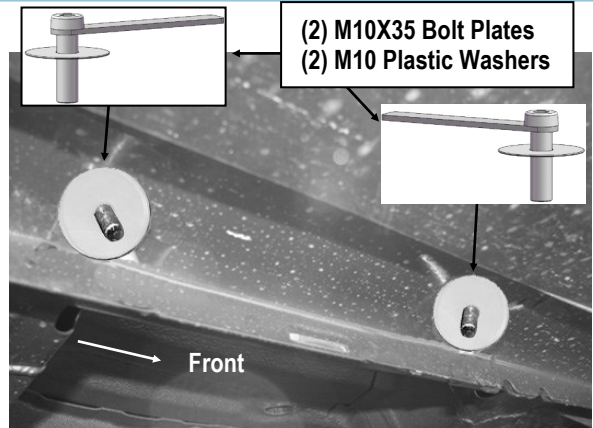

(Fig 2) M10X35 Bolt Plates Installed
(On Passenger Side Front Mounting Location)

STEP 3

Select (1) Mounting Plate, (Fig 3). Slide the Mounting Plate over the installed (2) M10X35 Bolt Plates. Secure the Mounting Plate to the rear Bolt Plate only with (1) M10 Large Flat Washer, (1) M10 Lock Washer and (1) M10 Hex Nut, (Figs 4&6). Tighten the Hex Nut.

Note: The Plates on the (2) Bolt Plates must be pointed toward each other, (Fig 3).

IMPORTANT: Repeat this **Step** for all (4) Mounting Plates installations.

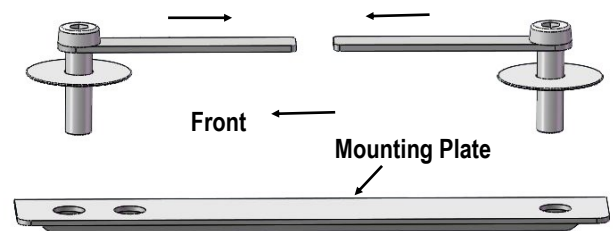

(Fig 3) Mounting Plate Installation
(On Passenger Side Front Mounting Location)

iArmor®

- (1) M10 Large Flat Washer
- (1) M10 Lock Washer
- (1) M10 Hex Nut

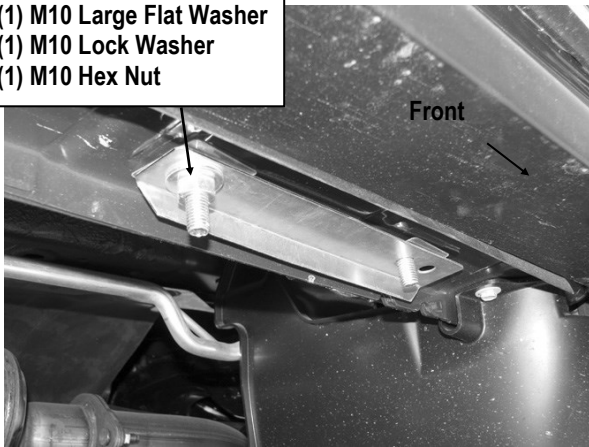

(Fig 4) Mounting Plate Installed
(On Passenger Side Front Mounting Location)

STEP 4

Locate the round hole on the inner side of the body panel, directly behind the previously installed M10X35 Bolt Plates, (Fig 5). Remove the rubber plug if equipped. Insert (1) M10X35 Bolt Plate into the round hole. And thread (1) M10 Plastic Washer onto the Bolt Plate down tight against the body panel.

IMPORTANT: Mounting areas may be covered by undercoating. Brackets should attach on the body panel flatly. Remove the undercoating on the bracket mounting area, if necessary.

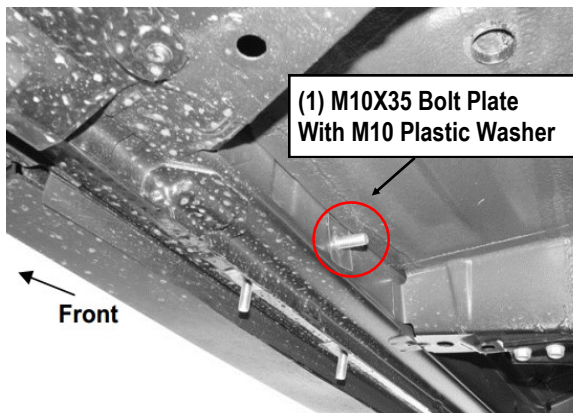

(Fig 5) M10X35 Bolt Plate Installed
(on the Inner Side of The Body Panel)

STEP 5

Select (1) Passenger Front Mounting Bracket (PFM). Attach the lower hole to the front Bolt Plate with (1) M10 Large Flat Washer, (1) M10 Lock Washer and (1) M10 Hex Nut, (Fig 6). Do not fully tighten hardware at this time.

Attach the upper hole of Passenger Front Mounting Bracket to the installed M10X35 Bolt Plate on the inner side of the body panel with (1) M10 Large Flat Washer, (1) M10 Lock Washer and (1) M10 Hex Nut, (Fig 7). Do not fully tighten hardware at this time.

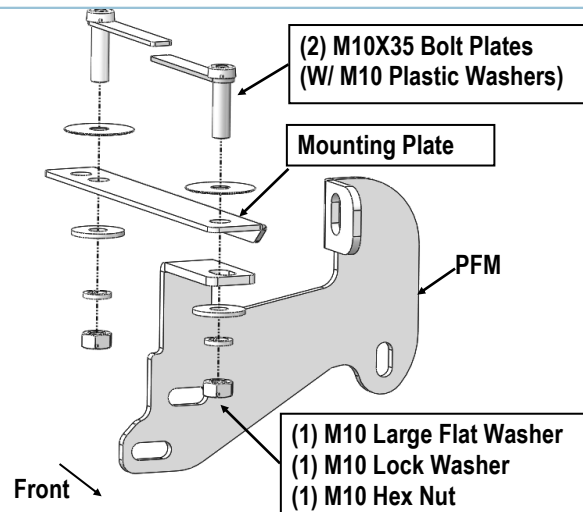

(Fig 6) Passenger Front Mounting Bracket Installation

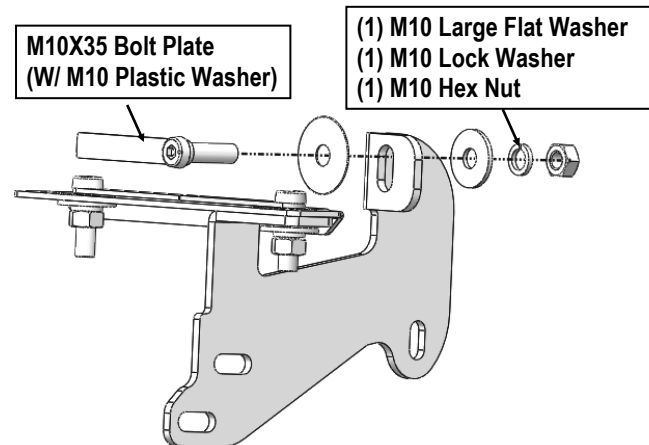

(Fig 7) Passenger Front Mounting Bracket Installation

STEP 6

Locate the factory holes at the bottom of the inner frame channel. **Determine the correct mounting hole for the Driver/ Passenger Front Support Bracket:**

Driver Side : Use the front factory hole (Fig 7).

Passenger side: Use the rear factory hole, (Fig 8).

Select (1) M10X35 Bolt Plate and (1) M10 Plastic Washer. Partially thread the M10 Plastic Washer onto the Bolt Plate. Insert the Bolt Plate into the correct factory hole in the frame channel (Figs 7 & 8).

Attach the short end of the Support Bracket to the installed M10X35 Bolt Plate on the frame channel with (1) M10 Flat Washer, (1) M10 Lock Washer and (1) M10 Hex Nut, (Figs 9 & 10). Bolt the other end of the Support Bracket to the front Mounting Bracket with (1) M8X1.25-30mm Hex Bolt, (2) M8 Large Flat Washers, (1) M8 Lock Washer and (1) M8 Hex Nut, (Figs 9 & 10). Do not fully tighten at this time.

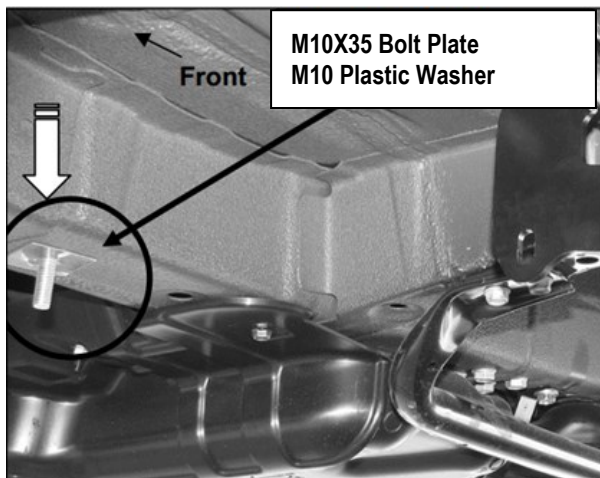

(Fig 7) Driver Front Support Bracket Location

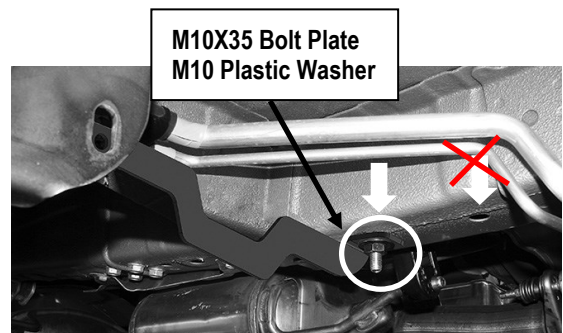

(Fig 8) Passenger Front Support Bracket Mounting Location

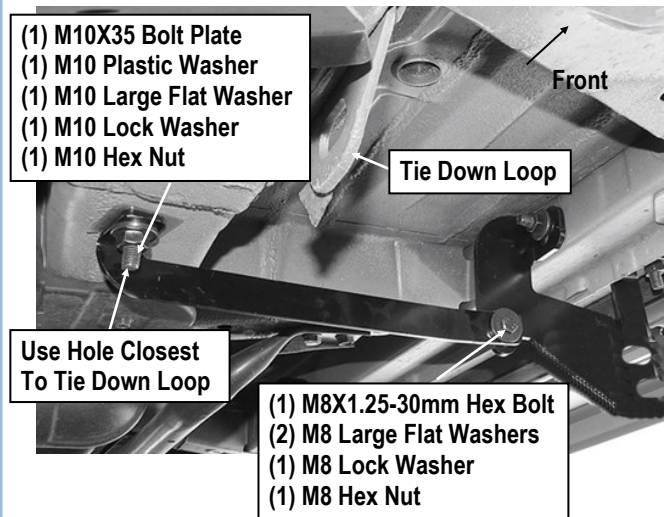

(Fig 9) Driver Front Support Bracket (DFS) Installed

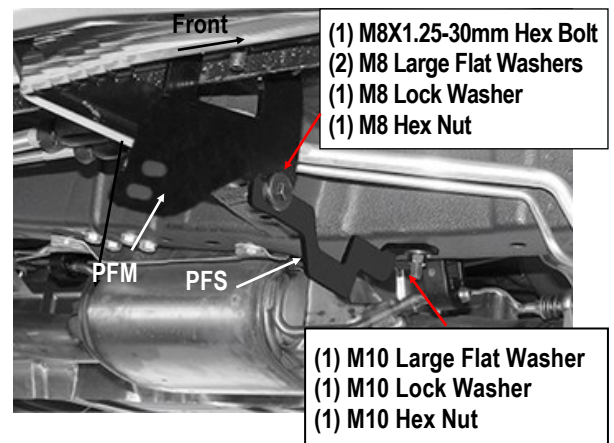

(Fig 10) Passenger Front Support Bracket (PFS) Installed

iArmor[®]

STEP 7

Move to the passenger side rear mounting location. Locate the large oval and the round holes on the inner body panel in front of the rear tire, (Fig 11). Select (1) M10X40 Double Bolt Plate and (1) M10 Plastic Washer. Insert the M10X40 Bolt Plate into the oval hole and up and out of the smaller round hole above it. Thread the Plastic Washer onto the M10X40 Bolt Plate in the round hole only, (Fig 12).

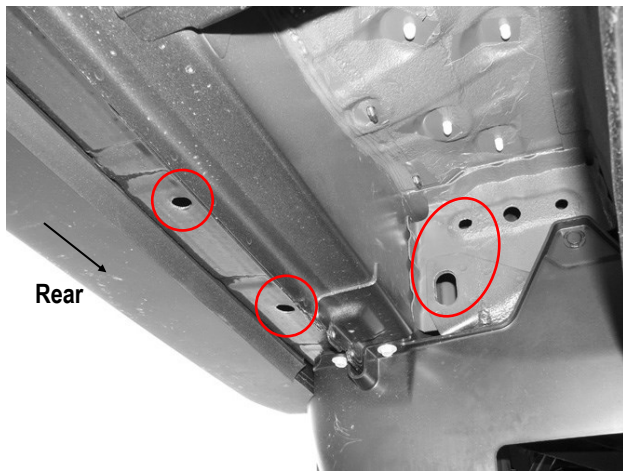

(Fig 11) Passenger Side Rear Mounting Location

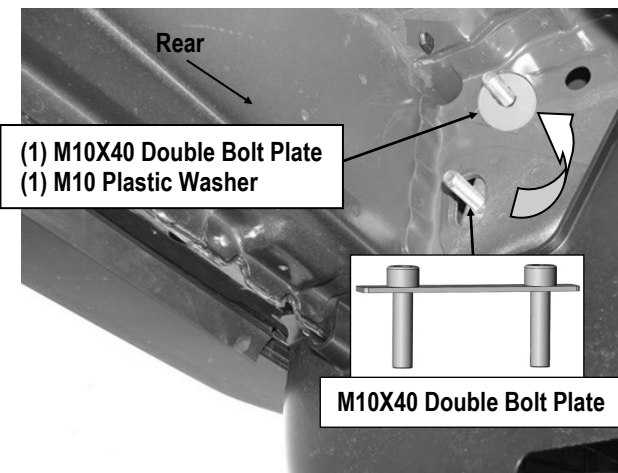

(Fig 12) M10X40 Double Bolt Plate Installed (on Passenger Side Rear Mounting Location)

STEP 8

Locate the last (2) round holes at the bottom of body panel. Repeat **Steps 1-3** to install the (2) M10X35 Bolt Plates and Mounting Plate, (Fig 13).

NOTE: Attach the Mounting Plate to the front of Bolt Plate only with (1) M10 Flat Washer, (1) M10 Lock Washer and (1) M10 Hex Nut, (Fig 14). Tighten the Hex Nut.

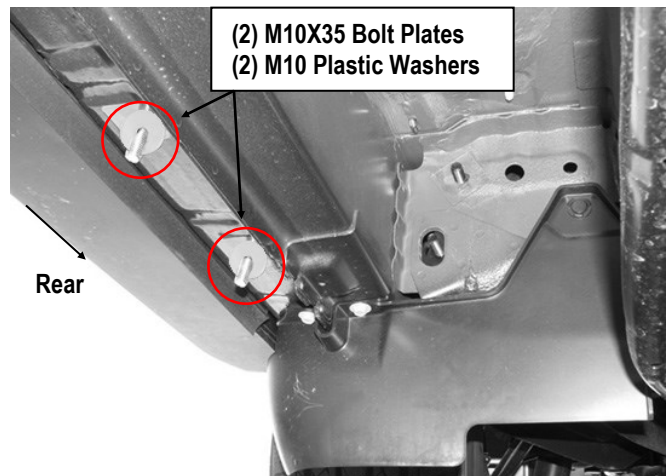

(Fig 13) M10X35 Bolt Plate Installed (on Passenger Side Rear Mounting Location)

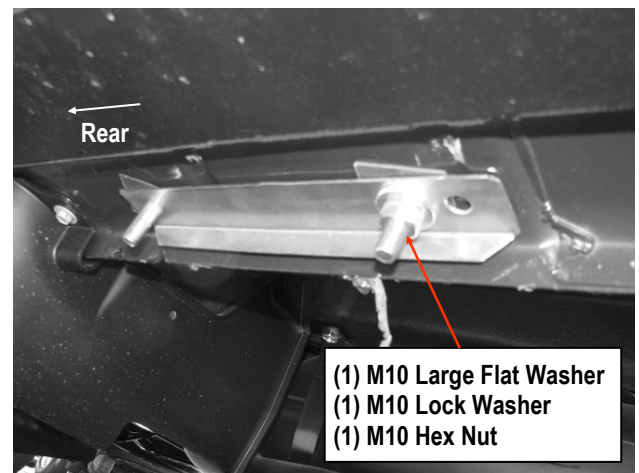

(Fig 14) Mounting Plate Installed (on Passenger Side Rear Mounting Location)

STEP 9

Select the Passenger Rear Mounting Bracket (**PRM**). Attach the Mounting Bracket to the installed M10X40 Double Bolt Plate with (2) M10 Large Flat Washers, (2) M10 Lock Washers and (2) M10 Hex Nuts, (**Figs 15&17**). Do not fully tighten hardware at this time.

Next, attach the Passenger Rear Bar Bracket (**PRB**) to the front of the installed Passenger Rear Mounting Bracket with (2) M8X1.25-30mm Hex Bolts, (4) M8 Large Flat Washers, (2) M8 Lock Washers and (2) M8 Hex Nuts, (**Figs 16&17**). Do not fully tighten hardware at this time.

Attach the Passenger Rear Support Bracket (**PRB**) to the installed M10X35 Bolt Plate with (1) M10 Large Flat Washer, (1) M10 Lock Washer and (1) M10 Hex Nut, (**Fig 17**). Do not fully tighten hardware at this time.

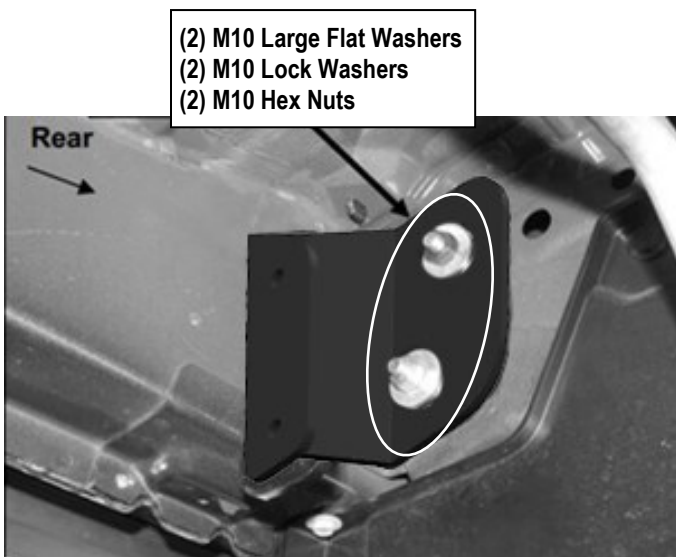

(Fig 15) Passenger Rear Mounting Bracket Installation

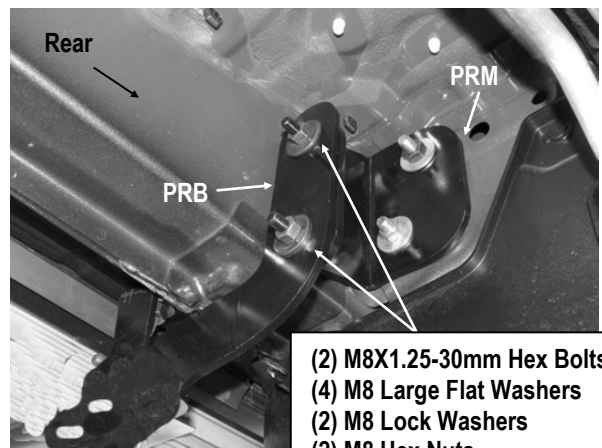

(Fig 16) Passenger Rear Mounting Bracket And Passenger Rear Bar Bracket Assembly

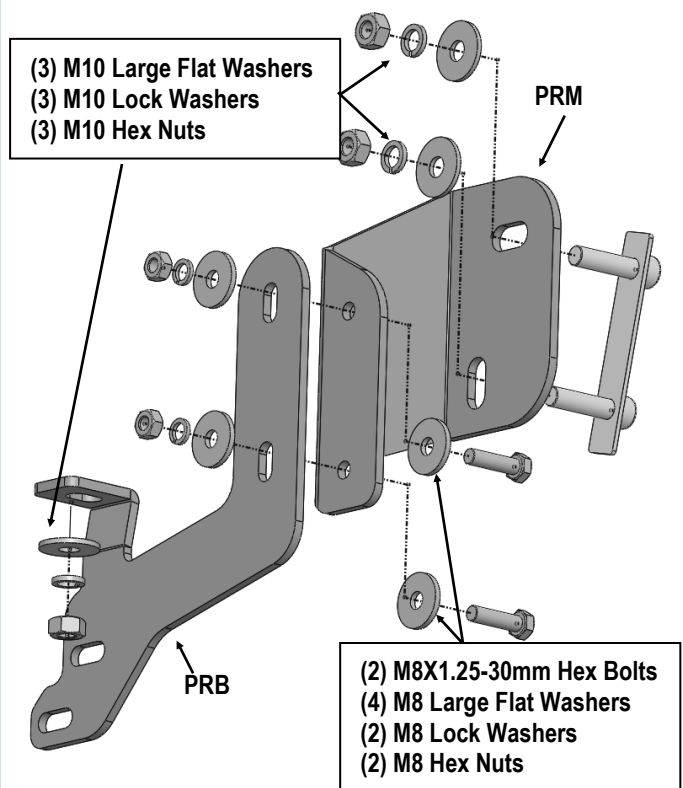

(Fig 17) Passenger Side Rear Brackets Installation

iArmor®

STEP 10

Once all (2) Mounting Brackets have been installed, attach the Driver Side Step Bar to the Mounting Brackets with (4) M10X1.5-25 Hex Bolts, (8) M10 Flat Washers and (4) M10X1.5 Nylon Lock Nuts, **(Fig 18)**. Do not fully tighten hardware at this time.

STEP 11

Properly level and adjust the Step Bar and fully tighten all hardware.

STEP 12

Move to the other side of the vehicle. Repeat **Steps 1-11** for the other Side Step Bar installation.

Attention

Do periodic inspections to the installation to make sure that all hardware is secure and tight.

In order to protect your bars/boards, please use mild soap/non-abrasive products for cleaning only.

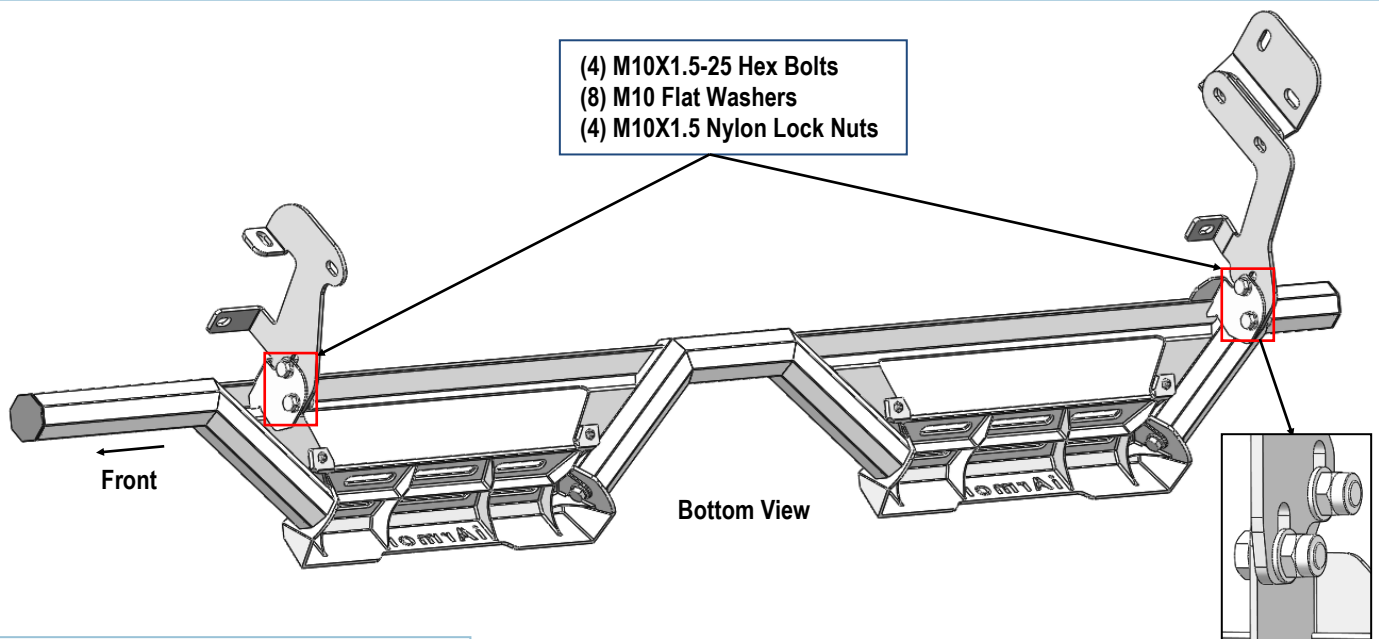

(Fig 18) Passenger Side Step Bar Installation