

iArmor[®]

iArmor[®] by APS

PART#: IA-S095

BEFORE INSTALLATION

REMOVE CONTENTS FROM BOX. VERIFY ALL PARTS ARE PRESENT. READ INSTRUCTIONS CAREFULLY BEFORE STARTING INSTALLATION. ASSISTANCE IS RECOMMENDED. THANK YOU FOR CHOOSING OUR PRODUCT!

*ROCKER PANEL MOUNT

*NO DRILLING /TRIMMING REQUIRED

Fastener Size	Tightening Torque (ft-lbs)	Required
6mm	6-7	X
8mm	16-18	√
10mm	31-32	X
12mm	56-58	X
14mm	92-94	X

Item	QTY	Description	Item	QTY	Description
1#	3	Driver Front / Center / Rear Mounting Brackets	6#	6	M8X1.25-55mm Carriage Bolts
2#	3	Passenger Front / Center / Rear Mounting Brackets	7#	6	M8 Large Flat Washers
3#	6	U Brackets	8#	6	M8 Lock Washers
4#	12	Spacers	9#	6	M8X1.25 Hex Nuts
5#	12	M8X1.25 Hex Flange Nuts			

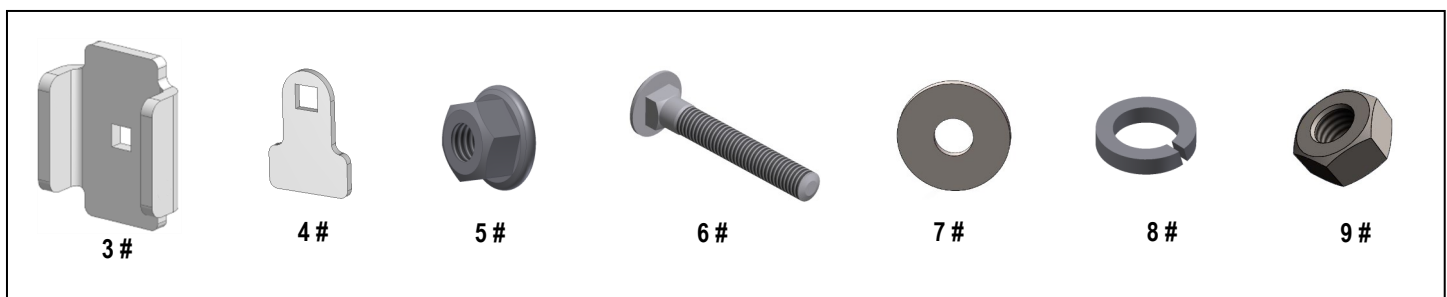

iArmor[®]

Driver

Front

Passenger

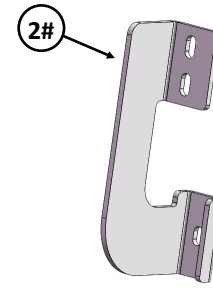
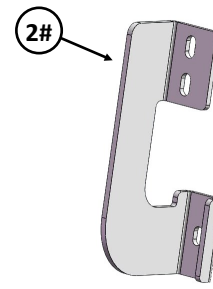
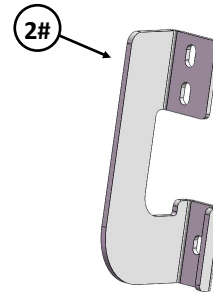
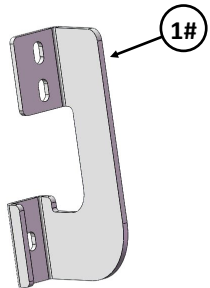
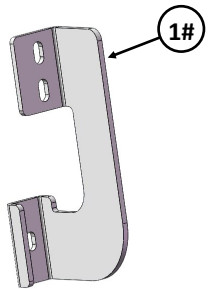
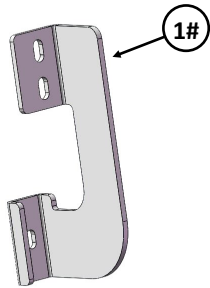
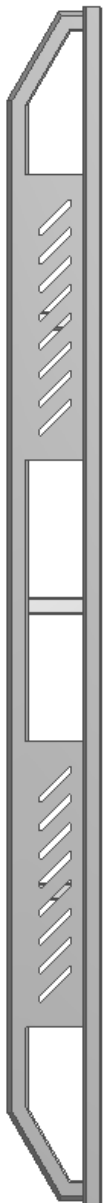

iArmor®

The instruction here is for your reference only. We strongly recommend the professional installer for best result. We are not responsible for any damage caused by the installation.

STEP 1

Start the installation under the driver side of the vehicle, **(Fig 1)**.

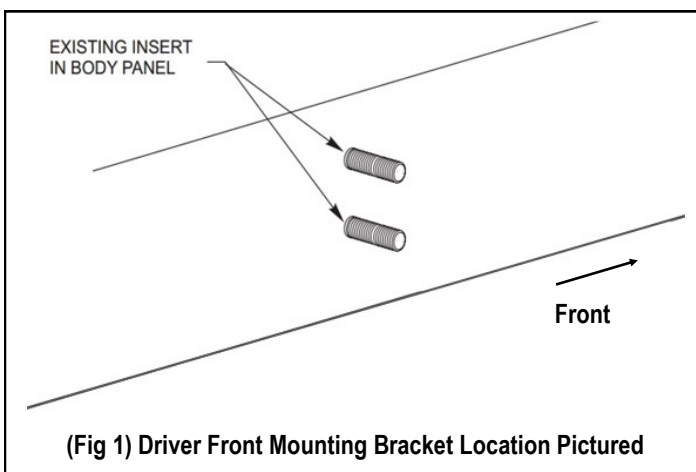

STEP 2

Select (1) Driver Front Mounting Bracket. **NOTE: Driver Front Mounting Bracket, Driver Center Mounting Bracket and Driver Rear Mounting Bracket are universal.** Attach the Mounting Bracket to the (2) factory studs with (2) M8X1.25 Hex Flange Nuts, **(Fig 2)**. Leave bracket loose at this time.

Repeat for Driver Center Mounting Bracket and Driver Rear Mounting Bracket.

STEP 3

Once all (3) driver side mounting brackets are installed, select and attach the Driver Side Step Bar onto the Mounting Brackets with (3) U Brackets, (6) Spacers, (3) M8X1.25-55mm Carriage Bolts, (3) M8 Large Flat Washers, (3) M8 Lock Washers and (3) M8X1.25 Hex Nuts, **(Fig 3)**. Do not fully tighten hardware at this time.

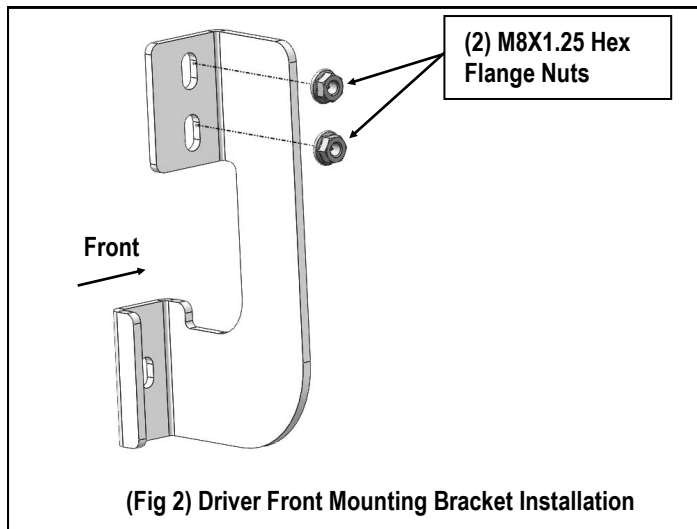

STEP 4

Properly level and adjust the Step Bar and fully tighten all hardware.

STEP 5

Move to the passenger side of the vehicle. Repeat **Steps 1-4** to install the passenger side step bar.

Installation completed.

Attention

Do periodic inspections to the installation to make sure that all hardware is secure and tight.

In order to protect your bars/boards, please use only mild soap/non-abrasive products for cleaning.

iArmor®

NOTE: Torque all M8 X1.25-55mm Carriage Bolts to 16~18 lb-ft. Don't over tighten, or the aluminum square bars will be damaged by the brackets

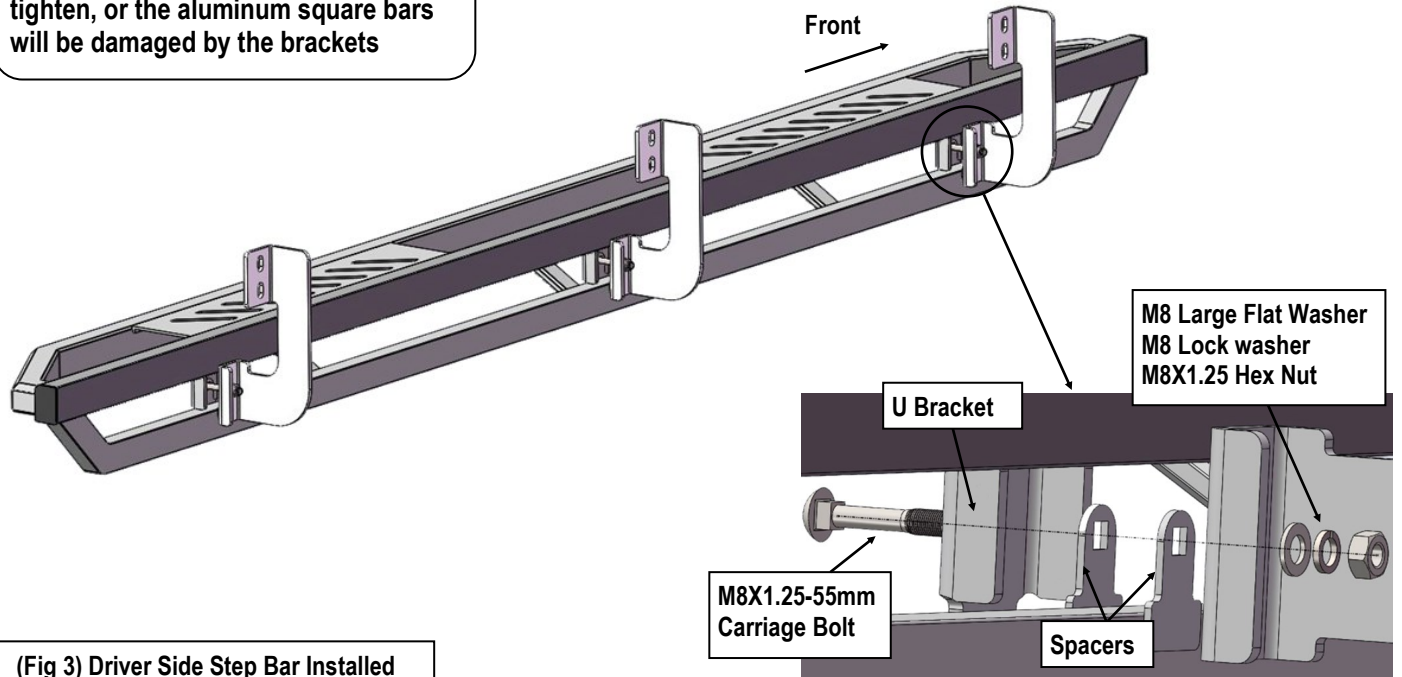

(Fig 3) Driver Side Step Bar Installed