

iArmor[®]

iArmor[®] by APS

PART#: IA-S050

BEFORE INSTALLATION

REMOVE CONTENTS FROM BOX. VERIFY ALL PARTS ARE PRESENT. READ INSTRUCTIONS CAREFULLY BEFORE STARTING INSTALLATION. ASSISTANCE IS RECOMMENDED. THANK YOU FOR CHOOSING OUR PRODUCT!

*ROCKER PANEL MOUNT

*NO DRILLING /TRIMMING REQUIRED

Fastener Size	Tightening Torque (ft-lbs)	Required
6mm	6-7	X
8mm	16-18	√
10mm	31-32	X
12mm	56-58	X
14mm	92-94	X

Item	QTY	Description	Item	QTY	Description
1#	6	Mounting Brackets	6#	18	M8 Lock Washers
2#	6	U Brackets	7#	6	M8X1.25 Hex Flange Nuts
3#	12	Spacers	8#	6	M8X1.25-55mm Carriage Bolts
4#	12	M8X1.25-25mm Hex Bolts	9#	6	M8X1.25 Hex Nuts
5#	18	M8 Large Flat Washers			

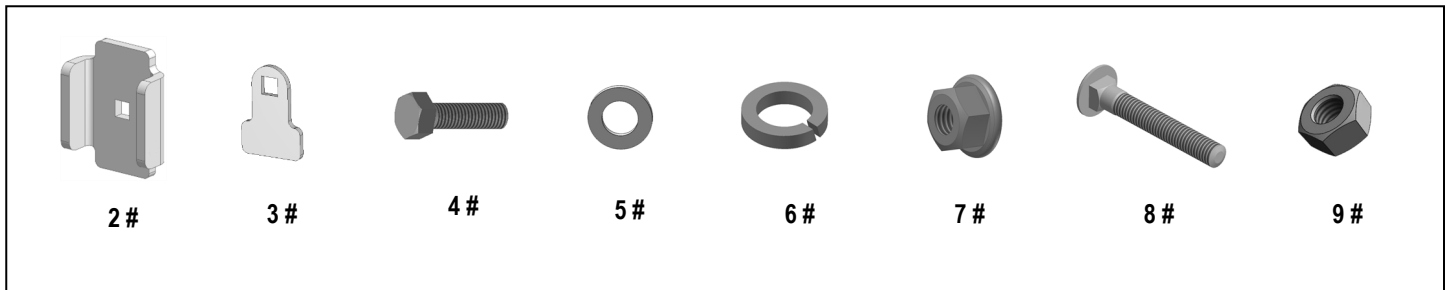

iArmor®

Driver

Front

Passenger

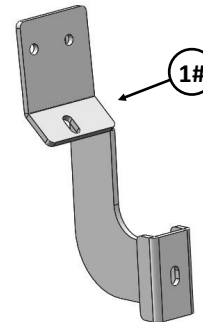
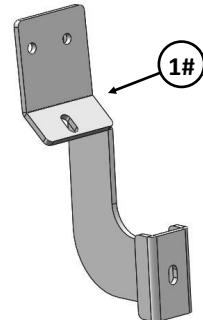
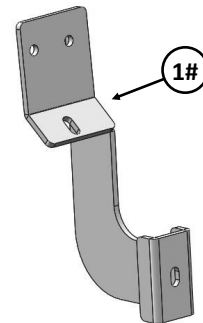
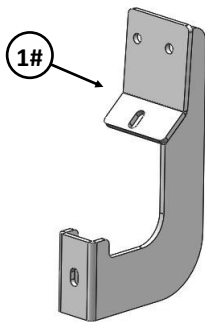
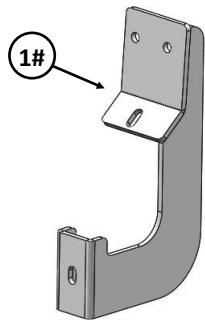
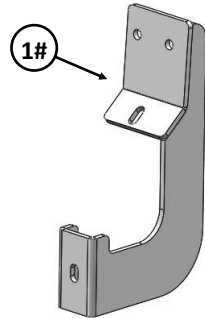
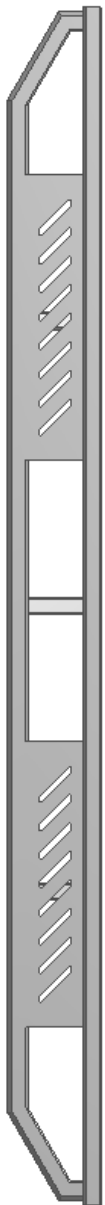

iArmor®

The instruction here is for your reference only. We strongly recommend the professional installer for best result. We are not responsible for any damage caused by the installation.

STEP 1

Start installation at the front of the driver side of the vehicle and locate the factory threaded holes or stud located on the side of the inner body panel, (Figs 1 & 2). **NOTE:** Remove the plastic plug or any insulation on the side panel to locate the threaded holes.

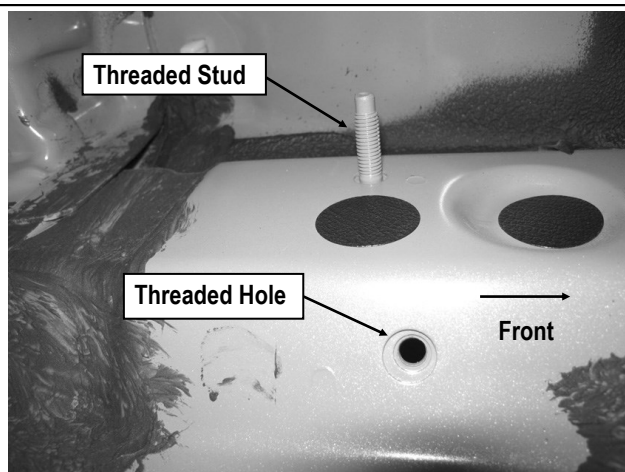

(Fig 1) Up To 2015 Driver Side Rear Mounting Location Pictured. Note: Remove Plastic Plugs To Locate Factory Threaded Holes

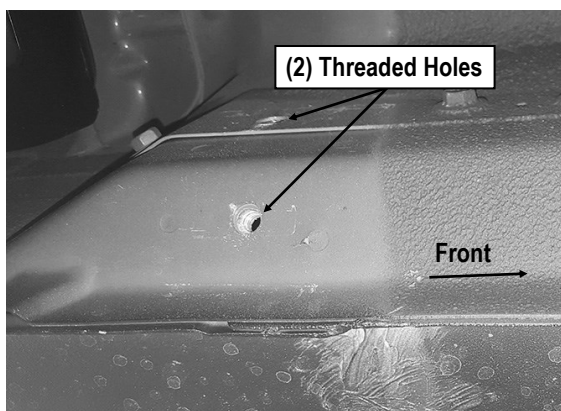

(Fig 2) 2016-On Driver Side Rear Mounting Location Pictured. Note: Two Factory Threaded Holes Only

STEP 2

Attach (1) Mounting Bracket onto the Driver Side Front Mounting Location as shown (Fig 3).

- Models with threaded stud:** Attach the Mounting Bracket to upper stud with (1) M8 X1.25 Hex Flange Nut. Next, secure the bracket to the lower threaded hole with (1) M8X1.25-25mm Hex Bolt, (1) M8 Flat Washer and (1) M8 Lock Washer. Do not fully tighten hardware at this time.
- Models without threaded stud:** Attach the Mounting Bracket to the upper threaded hole with (1) M8X1.25-25mm Hex Bolt, (1) M8 Flat Washer and (1) M8 Lock Washer. Next, secure the bracket to the lower threaded hole with (1) M8X1.25-25mm Hex Bolt, (1) M8 Flat Washer and (1) M8 Lock Washer. Do not fully tighten hardware at this time.

Repeat to Install the Driver Center and Rear mounting brackets.

STEP 3

Once all (3) driver side mounting brackets are installed, select and attach the Driver Side Step Bar onto the Mounting Brackets with (3) U Brackets, (6) Spacers, (3) M8X1.25-55mm Carriage Bolts, (3) M8 Flat Washers, (3) M8 Lock Washers and (3) M8X1.25 Hex Nuts (Fig 4). Do not fully tighten hardware at this time.

STEP 4

Properly level and adjust the Step Bar and fully tighten all hardware.

STEP 5

Move to the passenger side of the vehicle. Repeat **Steps 1-4** to install passenger side step bar.

iArmor®

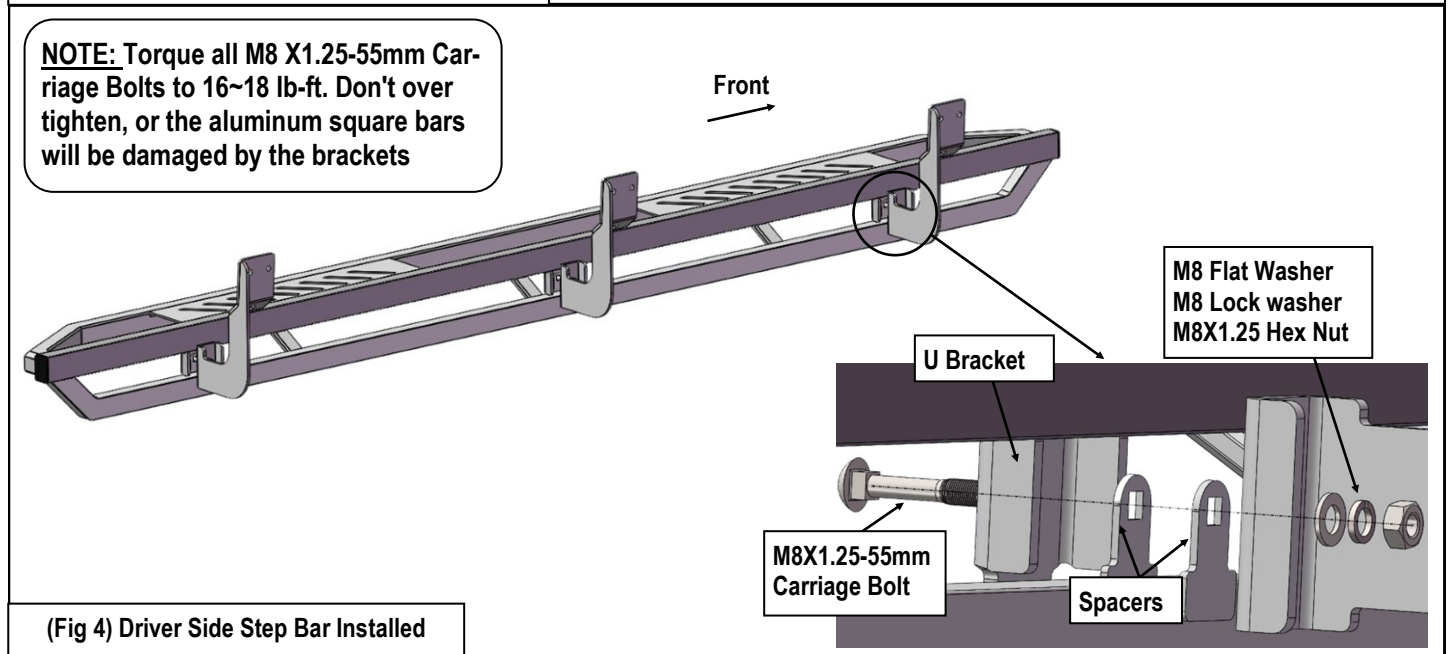
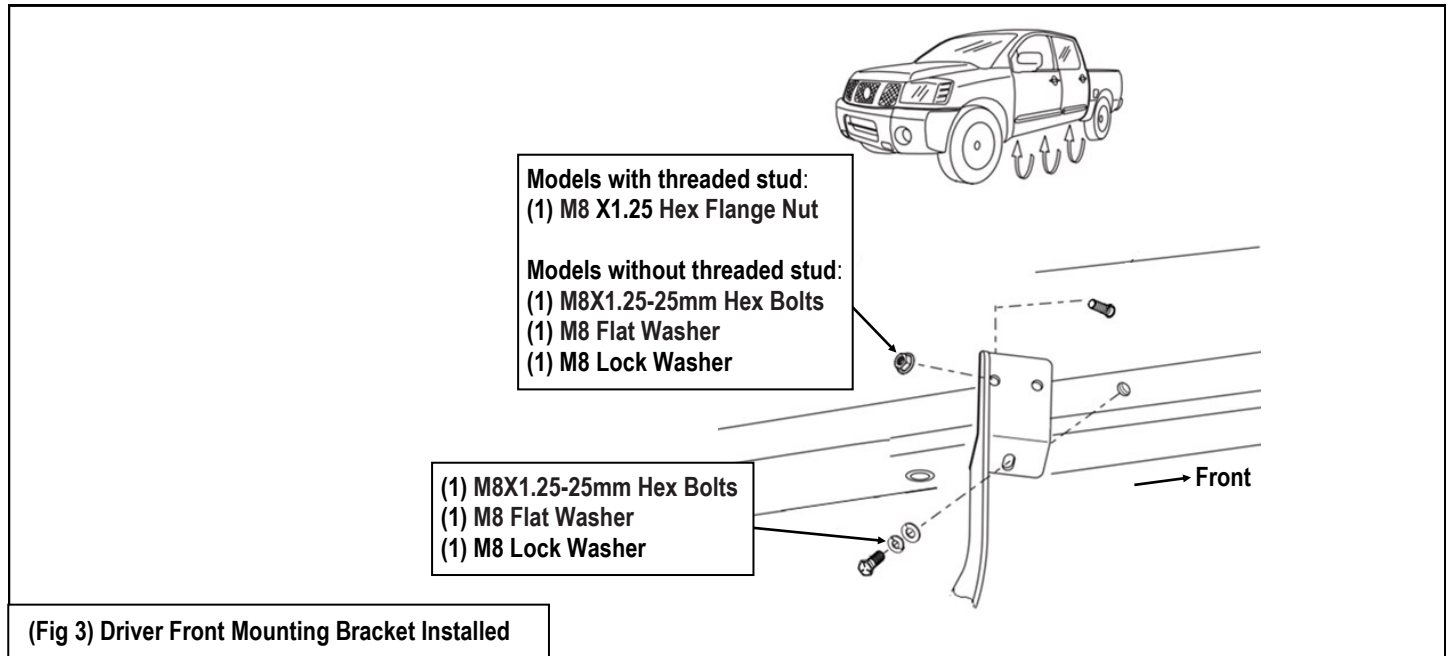

Attention

Do periodic inspections to the installation to make sure that all hardware is secure and tight.
In order to protect your bars/boards, please use only mild soap/non-abrasive products for cleaning.