

# iArmor<sup>®</sup>

## iArmor<sup>®</sup> by APS

PART#: IA-S972

### BEFORE INSTALLATION

REMOVE CONTENTS FROM BOX. VERIFY ALL PARTS ARE PRESENT. READ INSTRUCTIONS CAREFULLY BEFORE STARTING INSTALLATION. ASSISTANCE IS RECOMMENDED. THANK YOU FOR CHOOSING OUR PRODUCT!

**\*ROCKER PANEL MOUNT**

**\*NO DRILLING / TRIMMING REQUIRED**

### Torque Value

Fastener Size	Tightening Torque (ft-lbs)	Required
6mm	6-7	X
8mm	16-18	√
10mm	31-32	√
12mm	56-58	X
14mm	92-94	X

### PART LIST

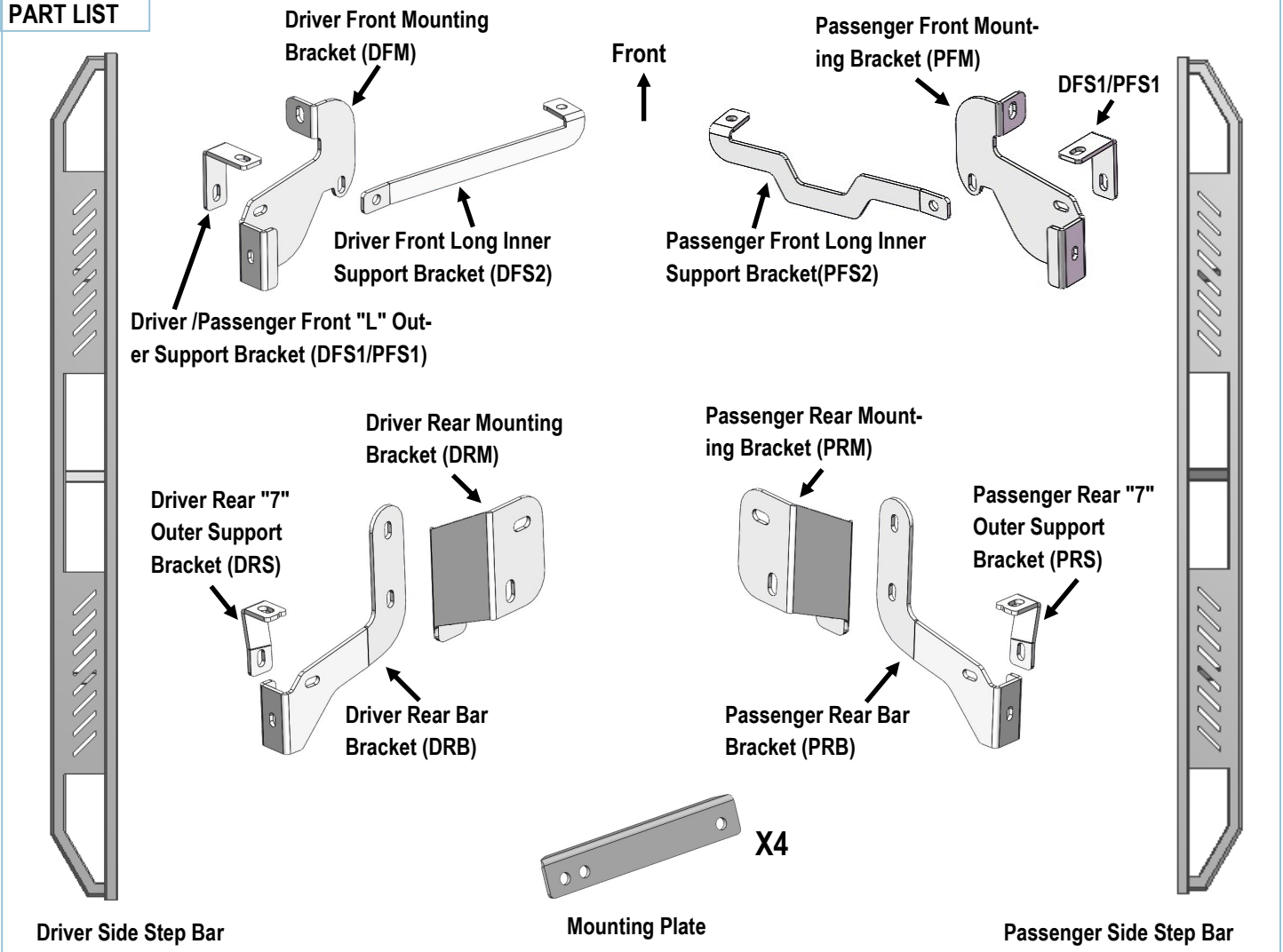

Customer Support: [info@iarmorauto.com](mailto:info@iarmorauto.com)

# iArmor®

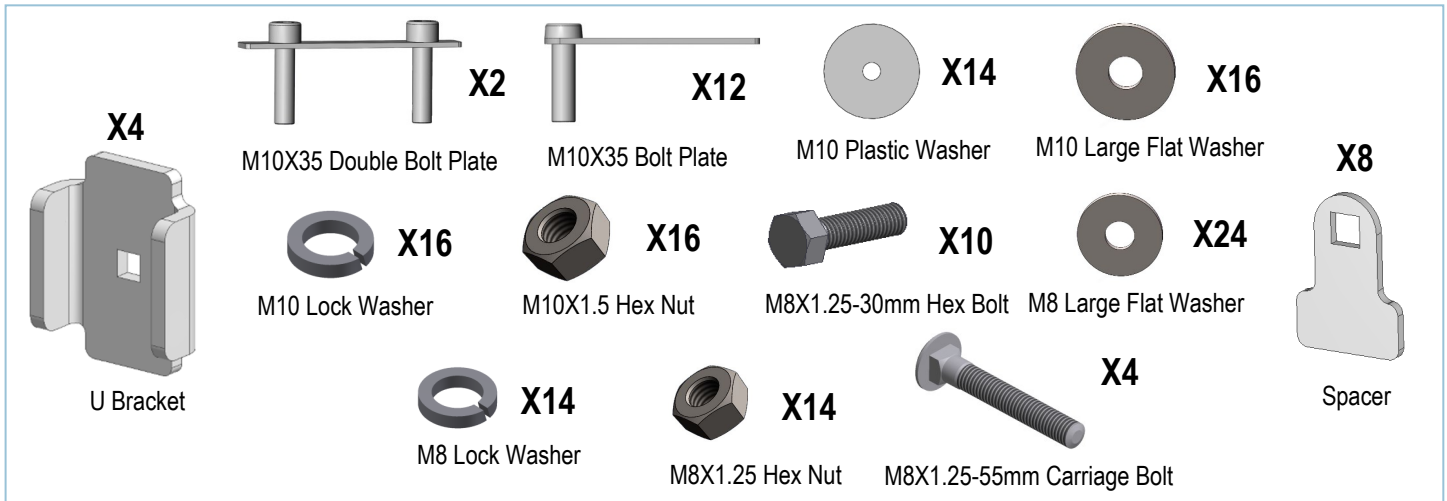

The instruction here is for your reference only. We strongly recommend the professional installer for best result. We are not responsible for any damage caused by the installation.

## STEP 1

Start installation on the passenger side front of the vehicle. Locate and remove the (3) rubber plugs in the bottom of the outer frame channel closest to the front wheel opening, (Fig 1).

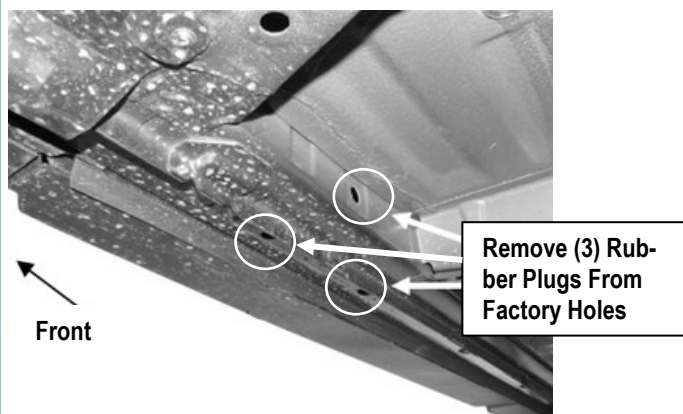

(Fig 1) Passenger Side Front Mounting Location Pictured

## STEP 2

Select (2) M10X35 Bolt Plates and (2) M10 Plastic Washers. Partially thread the M10 Plastic Washer onto the Bolt Plate, **NOTE:** The Plastic Washer is designed to hold the Bolt Plate in place during Bracket installation.

Insert (1) M10X35 Bolt Plate into the most front hole with the plate pointed toward the rear of the vehicle, (Fig 2). Thread the M10 Plastic Washer down tight against the body panel. Repeat to install the other M10X35 Bolt Plate into the second hole with the Mounting Plate pointed toward the front of the vehicle, (Fig 3).

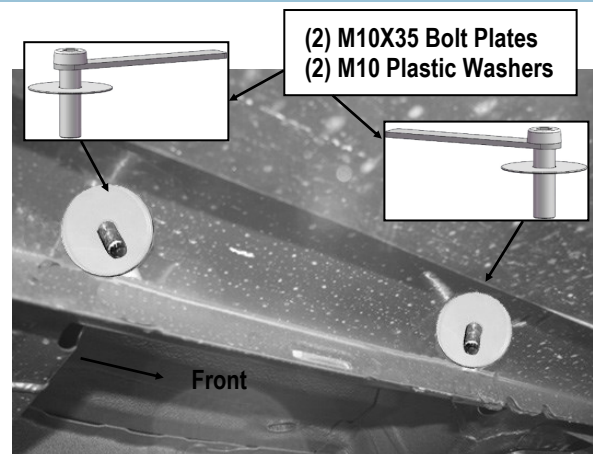

(Fig 2) M10X35 Bolt Plates Installed  
(On Passenger Side Front Mounting Location)

# iArmor®

## STEP 3

Select (1) Mounting Plate, (Fig 3). Slide the Mounting Plate over the installed (2) M10X35 Bolt Plates. Secure the Mounting Plate to the rear Bolt Plate only with (1) M10 Large Flat Washer, (1) M10 Lock Washer and (1) M10 X1.5 Hex Nut, (Fig 4). Tighten the Hex Nut.

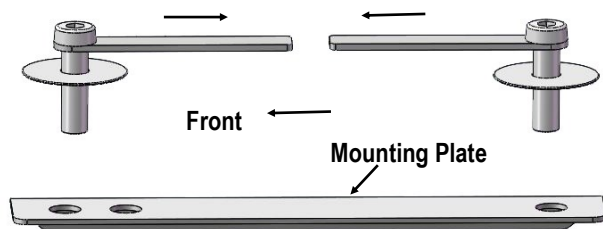

(Fig 3) Mounting Plate Installation  
(On Passenger Side Front Mounting Location)

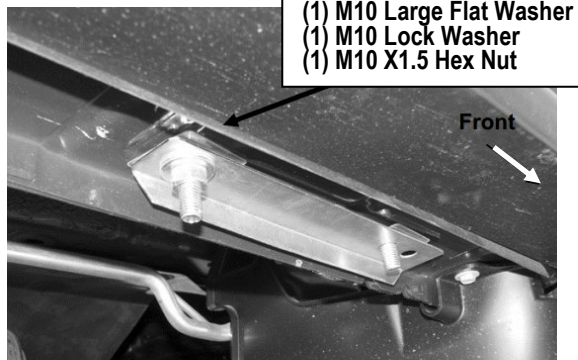

(Fig 4) Mounting Plate Installed  
(On Passenger Side Front Mounting Location)

## STEP 4

Locate the round hole on the inner side of the body panel, directly behind the previously installed M10X35 Bolt Plates, (Fig 5). Remove the rubber plug. Insert (1) M10X35 Bolt Plate into the round hole. And thread (1) M10 Plastic Washer onto the Bolt Plate down tight against the body panel.

**IMPORTANT:** Mounting areas may cover by undercoating. Brackets should attach on the body panel flatly. Remove the undercoating on the bracket mounting area, if necessary.

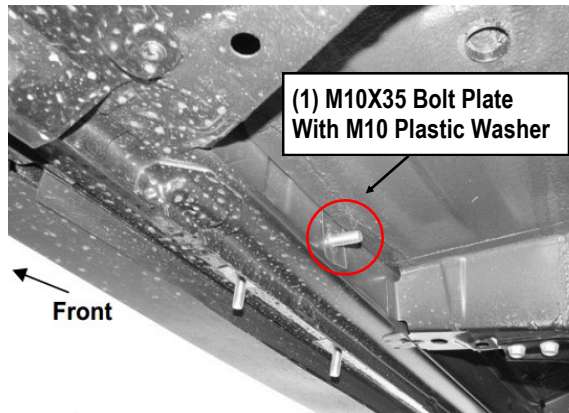

(Fig 5) M10X35 Bolt Plate Installed  
(on the Inner Side Of The Body Panel)

## STEP 5

Select (1) Passenger Front "L" Outer Support Bracket (DFS1/PFS1). Attach the shorter leg on the Passenger Front "L" Outer Support Bracket to the front Bolt Plate with (1) M10 Large Flat Washer, (1) M10 Lock Washer and (1) M10 X1.5 Hex Nut, (Fig 6). Do not fully tighten hardware at this time.

**Note:** Passenger Front "L" Outer Support Bracket (DFS1/PFS1) and Passenger Rear "7" Outer Support Bracket (PRS) are different.

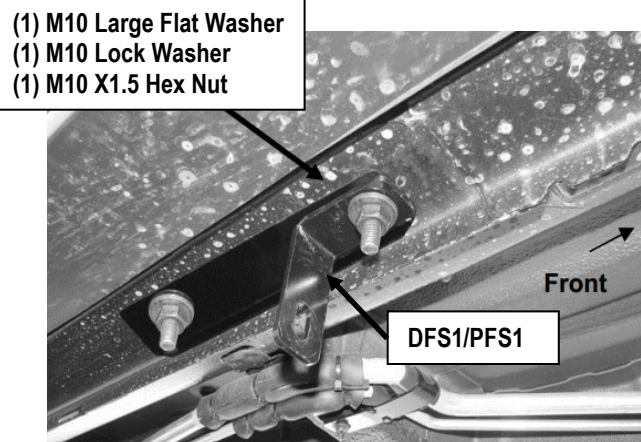

(Fig 6) Passenger Front "L" Outer Support Bracket Installed

# iArmor®

## STEP 6

Select the Passenger Front Mounting Bracket (**PFM**). Attach the bracket to the installed M10X35 Bolt Plate on the inner side of the body panel with (1) M10 Large Flat Washer, (1) M10 Lock Washer and (1) M10 X1.5 Hex Nut, (**Fig 7**). And then, secure the Mounting Bracket to the installed Passenger Front "L" Outer Support Bracket (**DFS1/PFS1**) with (1) M8X1.25-30mm Hex Bolt, (2) M8 Large Flat Washers, (1) M8 Lock Washer and (1) M8 X1.25 Hex Nut, (**Fig 8**). Do not fully tighten hardware at this time.

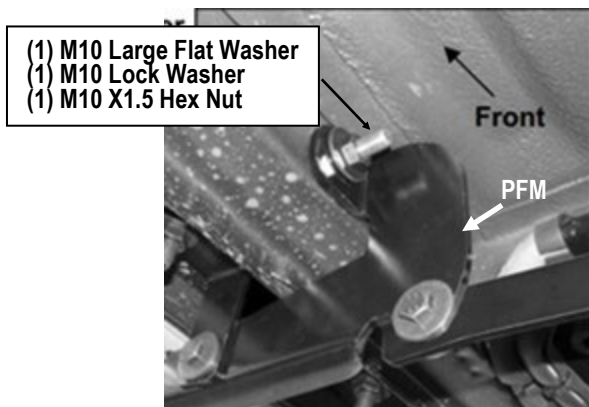

(Fig 7) Passenger Front Mounting Bracket Installed  
(to the Installed Bolt Plate on Body Panel)

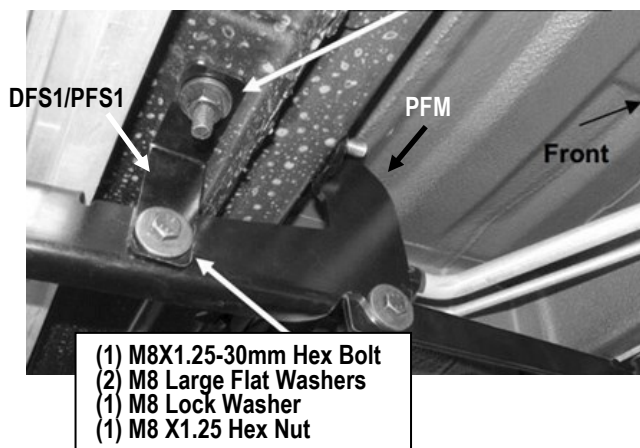

(Fig 8) Passenger Front Mounting Bracket Installed  
(to the Installed DFS1/PFS1)

## STEP 7

Locate the factory holes in the bottom of the inner frame channel. **Determine the correct mounting hole:**

**Driver side :** Use the front factory hole (**Fig 9**).

**Passenger side:** Use the rear factory hole, (**Fig 10**).

Select (1) M10X35 Bolt Plate and (1) M10 Plastic Washer. Partially thread the M10 Plastic Washer onto the Bolt Plate. Insert the Bolt Plate into the correct factory hole in the frame channel (**Fig 9 & 10**).

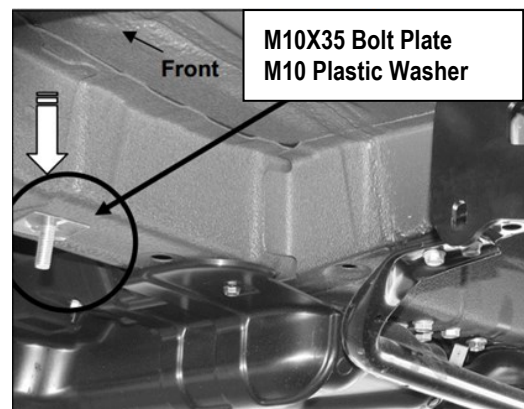

(Fig 9) Driver Front Long Inner Support Bracket Location

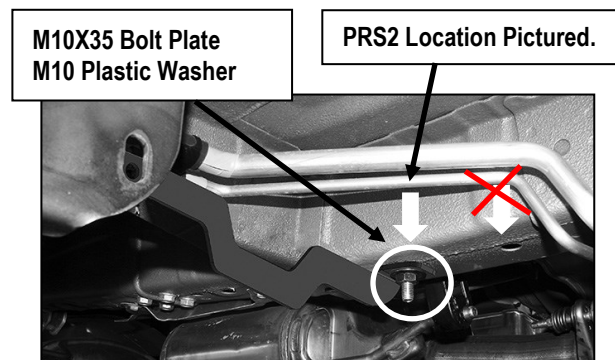

(Fig 10) Passenger Front Long Inner Support Bracket Location

# iArmor®

## STEP 8

Attach the 90-degree bent end of the Support Bracket to the installed M10X35 Bolt Plate on the frame channel with (1) M10 Large Flat Washer, (1) M10 Lock Washer and (1) M10 X1.5 Hex Nut, (Fig 11). Bolt the other end of the Support Bracket to the front Mounting Bracket with (1) M8X1.25-30mm Hex Bolt, (2) M8 Large Flat Washers, (1) M8 Lock Washer and (1) M8 X1.25 Hex Nut, (Fig 11A & 11B). Do not fully tighten at this time.

- (1) M8X1.25-30mm Hex Bolt
- (2) M8 Large Flat Washers
- (1) M8 Lock Washer
- (1) M8 X1.25 Hex Nut

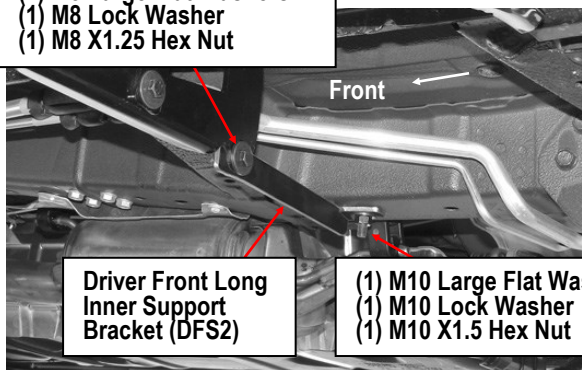

Driver Front Long Inner Support Bracket (DRS2)

- (1) M10 Large Flat Washer
- (1) M10 Lock Washer
- (1) M10 X1.5 Hex Nut

(Fig 11A) Driver Front Long Inner Support Bracket (DRS2) Installed

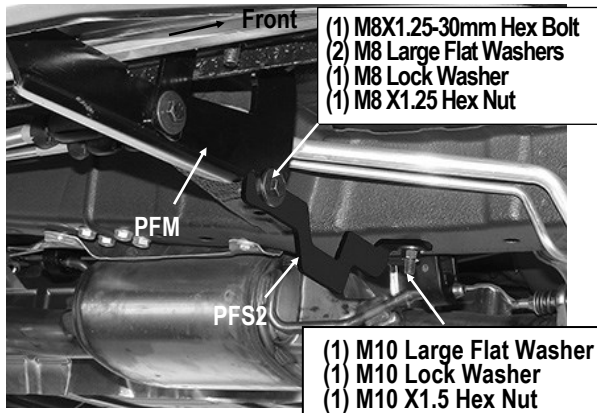

- (1) M8X1.25-30mm Hex Bolt
- (2) M8 Large Flat Washers
- (1) M8 Lock Washer
- (1) M8 X1.25 Hex Nut

- (1) M10 Large Flat Washer
- (1) M10 Lock Washer
- (1) M10 X1.5 Hex Nut

(Fig 11B) Passenger Front Long Inner Support Bracket (PRS2) Installed

## STEP 9

Move to the passenger side rear mounting location. Locate the large oval and the round holes on the inner body panel in front of the rear tire, (Fig 12). Select (1) M10X35 Double Bolt Plate and (1) M10 Plastic Washer. Insert the M10X35 Bolt Plate into the oval hole and up and out of the smaller round hole above it. Thread the Plastic Washer onto the M10X35 Bolt Plate in the round hole only, (Fig 13)

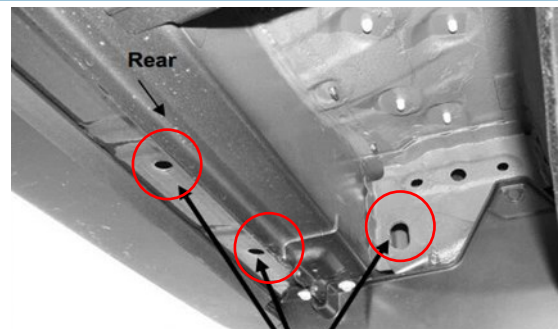

(Fig 12) Passenger Side Rear Mounting Location Pictured

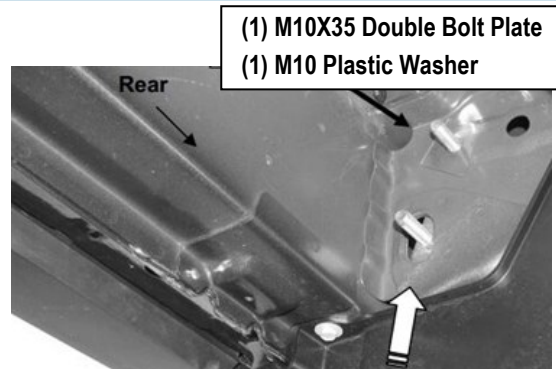

- (1) M10X35 Double Bolt Plate
- (1) M10 Plastic Washer

(Fig 13) M10X35 Double Bolt Plate Installed (on Passenger Side Rear Mounting Location)

## STEP 10

Locate the last (2) round holes at the bottom of body panel. Repeat **Steps 1-3** to install the (2) M10X35 Bolt Plates and Mounting Plate, (Fig 14).

**NOTE:** Attach the Mounting Plate to the front of Bolt Plate only with (1) M10 Large Flat Washer, (1) M10 Lock Washer and (1) M10 X1.5 Hex Nut, (Fig 15). Tighten the Hex Nut.

# iArmor®

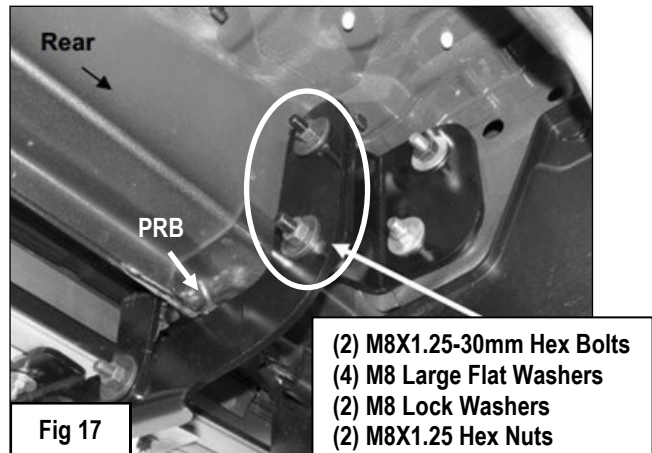
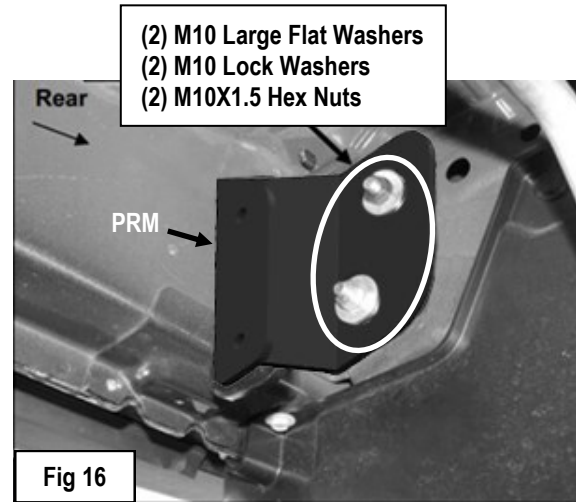
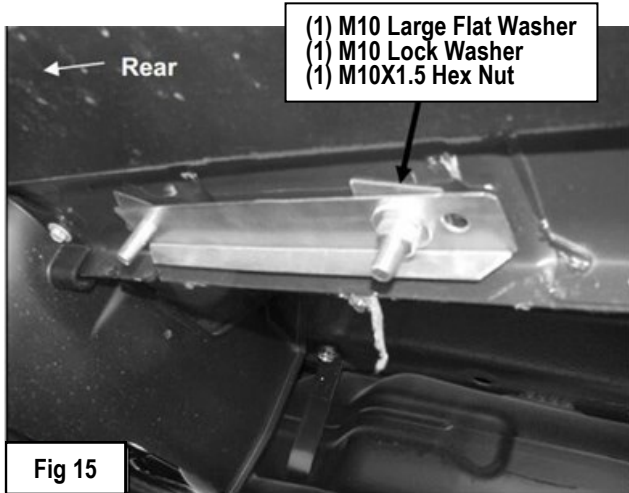
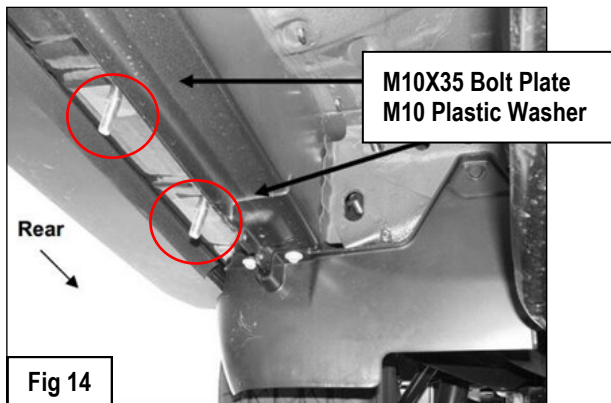

## STEP 11

Select the Passenger Rear Mounting Bracket (**PRM**). Attach the Mounting Bracket to the installed M10X35 Double Bolt Plate with (2) M10 Large Flat Washers, (2) M10 Lock Washers and (2) M10 X1.5 Hex Nuts, (**Fig 16**). Do not fully tighten hardware at this time.

Next, attach the Passenger Rear Bar Bracket (**PRB**) to the front of the installed Passenger Rear Mounting Bracket with (2) M8X1.25-30mm Hex Bolts, (4) M8 Large Flat Washers, (2) M8 Lock Washers and (2) M8 X1.25 Hex Nuts, (**Fig 17**). Do not fully tighten hardware at this time.

## STEP 12

Attach the Passenger Rear "7" Outer Support Bracket (**PRS**) to the rear of M10X35 Bolt Plate with (1) M10 Large Flat Washer, (1) M10 Lock Washer and (1) M10 X1.5 Hex Nut, (**Fig 18 & 19**). Do not fully tighten hardware at this time.

Bolt the Passenger Rear "7" Outer Support Bracket (**PRS**) to the back of the Passenger Rear Bar Bracket (**PRB**) with (1) M8X1.25-30mm Hex Bolt, (2) M8 Large Flat Washers, (1) M8 Lock Washer and (1) M8 X1.25 Hex Nut, (**Fig 18 & 19**). Do not fully tighten hardware at this time.

# iArmor®

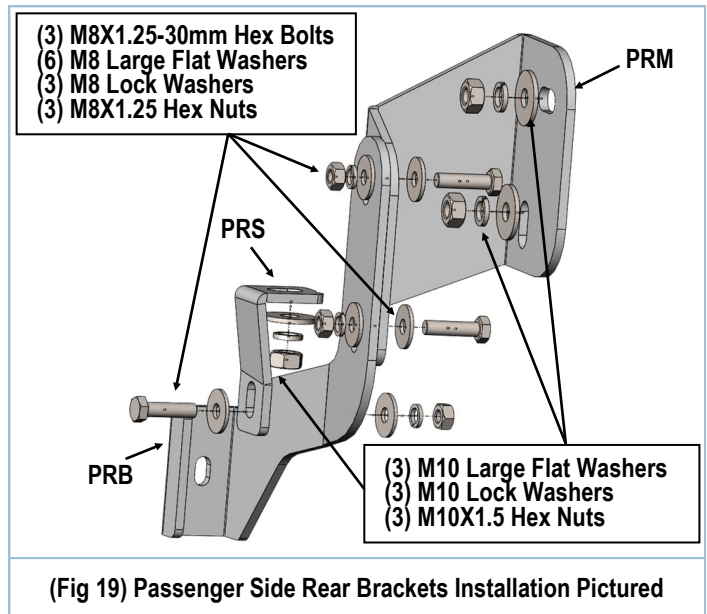
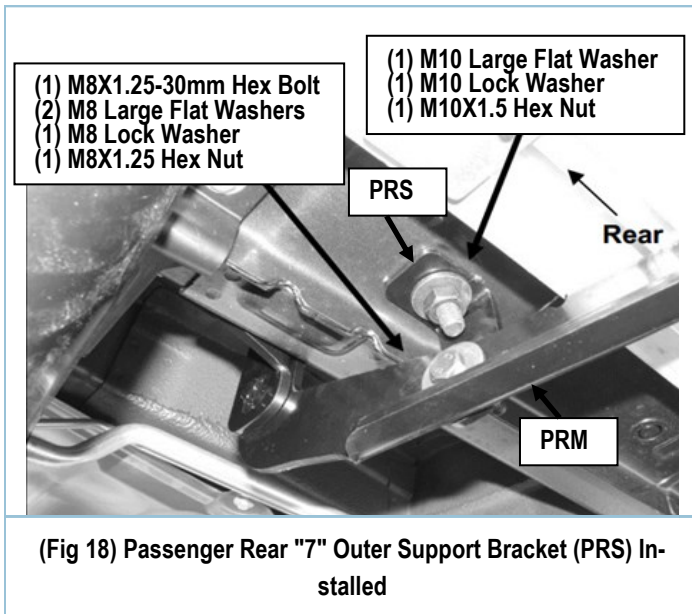

## STEP 13

Once all (2) Passenger side mounting brackets are installed, select and attach the Passenger Side Step Bar onto the Mounting Brackets with (2) U Brackets, (4) Spacers, (2) M8X1.25-55mm Carriage Bolts, (2) M8 Large Flat Washers, (2) M8 Lock Washers and (2) M8X1.25 Hex Nuts (Fig 20). Do not fully tighten hardware at this time.

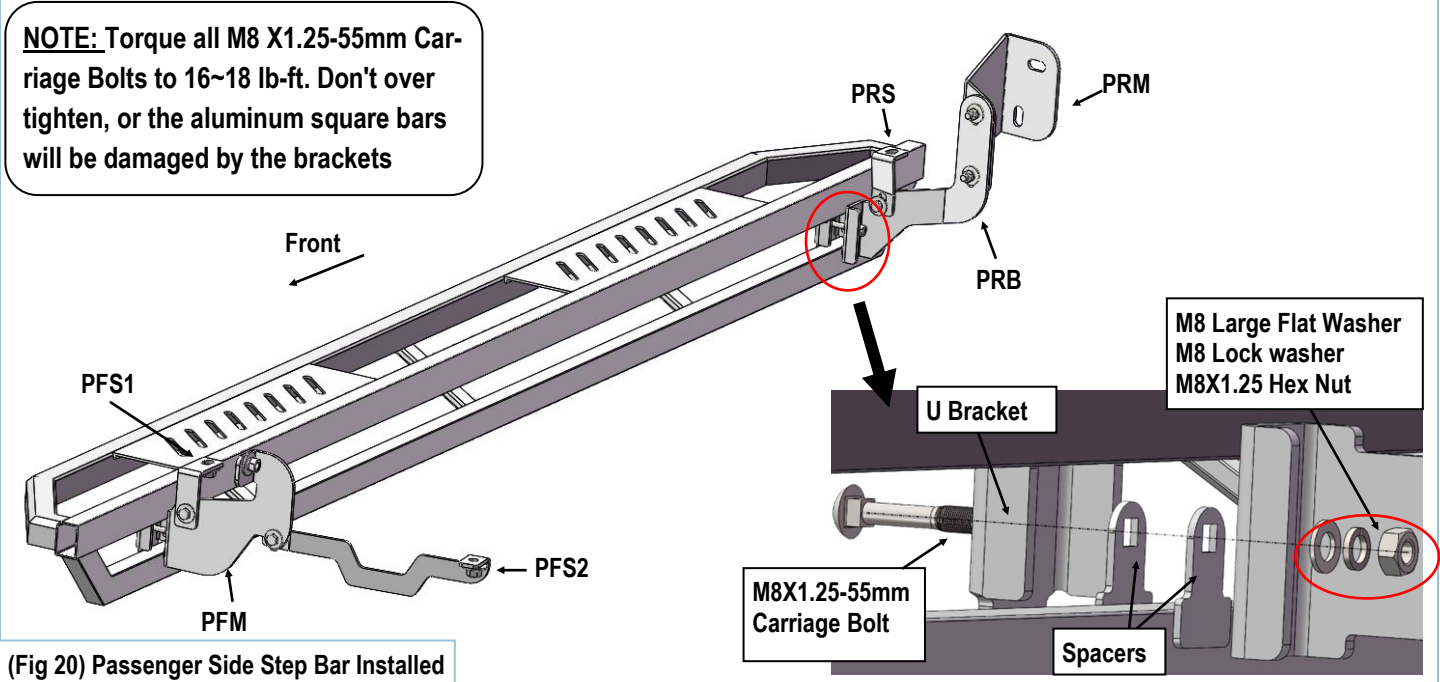

# iArmor<sup>®</sup>

## STEP 14

Properly level and adjust the Step Bar and fully tighten all hardware.

## STEP 15

Move to the driver side of the vehicle. Repeat **Steps 1-14** to install driver side step bar.

Installation completed.

### Attention

**Do periodic inspections to the installation to make sure that all hardware is secure and tight.**

**In order to protect your bars/boards, please use only mild soap/non-abrasive products for cleaning.**