

IARMOR EDGE™

PART#: IA-N050

BEFORE INSTALLATION

REMOVE CONTENTS FROM BOX. VERIFY ALL PARTS ARE PRESENT. READ INSTRUCTIONS CAREFULLY BEFORE STARTING INSTALLATION. ASSISTANCE IS RECOMMENDED. THANK YOU FOR CHOOSING OUR PRODUCT!

*DRILLING NOT REQUIRED

*TRIMMING NOT REQUIRED

Torque Value

Fastener Size	Tightening Torque (ft-lbs)	Required
6mm	6-7	√
8mm	16-18	√
10mm	31-32	X
12mm	56-58	X
14mm	92-94	X

PART LIST

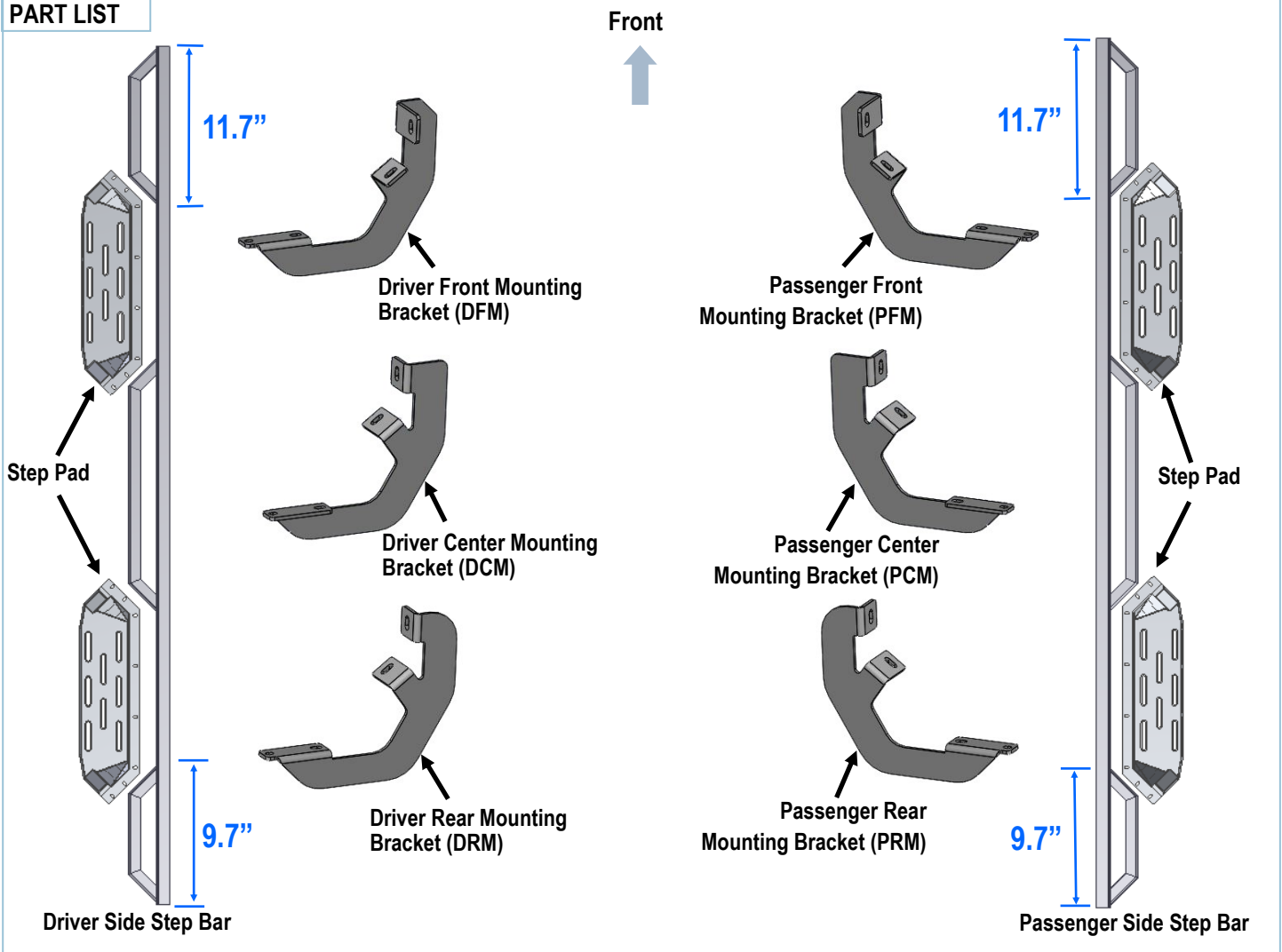

Customer Support: info@iarmorauto.com

iArmor[®]



X12

M8X1.25-30 Hex Bolt



X12

M8 Flat Washer



X12

M8 Lock Washer



X6

M8X1.25 Nylon Lock Nut

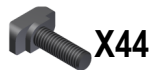

X44

M6X1-20 T-Bolt



X44

M6 Large Flat Washer



X44

M6X1 Nylon Lock Nut

The instruction here is for your reference only. We strongly recommend the professional installer for best result. We are not responsible for any damage caused by the installation.

STEP 1

Install the Step Pads onto the step bars with (32) M6X1-20 T-Bolts, (32) M6 Large Flat Washers and (32) M6X1 Nylon Lock Nuts.

IMPORTANT: Don't hit the step pad by any metal hammer within step pad installation, or the step pad will be damaged.

(8) M6X1-20 T-Bolts
(8) M6 Flat Washers
(8) M6 Nylon Lock Nuts

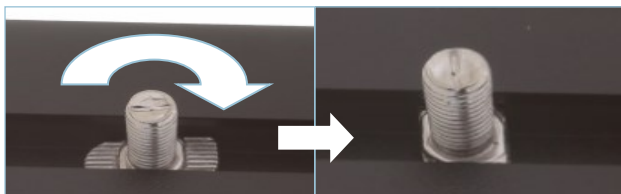

Note: Rotate 90° after inserting the T-Bolts into the Channel!!!

STEP 2

Start installation at the front of the driver side of the vehicle and locate the factory threaded holes or stud located on the side of the inner body panel, (Figs 1 & 2). **NOTE:** Remove the plastic plug or any insulation on the side panel to locate the threaded holes.

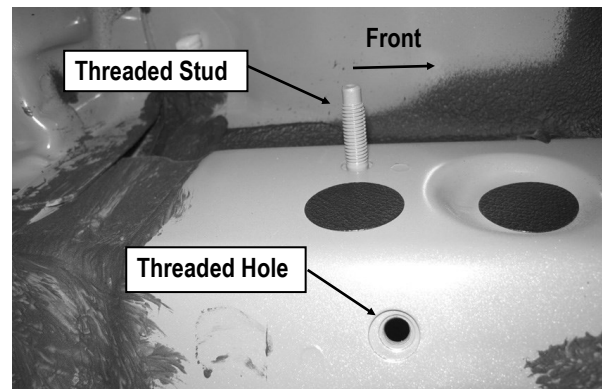

(Fig 1) Up To 2015 Driver Side Rear Mounting Location Pictured.
Note: Remove Plastic Plugs To Locate Factory Threaded Hole

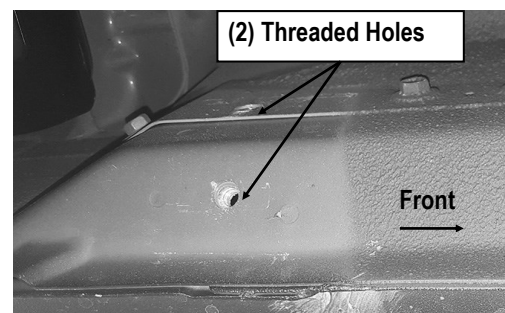

(Fig 2) 2016-On Driver Side Rear Mounting Location Pictured.
Note: Two Factory Threaded Holes Only

Customer Support: info@iarmorauto.com

iArmor®

STEP 3

Attach (1) Driver Front Mounting Bracket (**DFM**) onto the Driver Side Front Mounting Location as shown (**Fig 3**).

- a. **Models with threaded stud:** Attach the Mounting Bracket to upper stud with (1) M8 Flat Washer and (1) M8 Nylon Lock Nut. Next, secure the bracket to the lower threaded hole with (1) M8X1.25-30 Hex Bolt, (1) M8 Flat Washer and (1) M8 Lock Washer. Do not tighten hardware at this time.
- b. **Models without threaded stud:** Attach the Mounting Bracket to the upper threaded hole with (1) M8X1.25-30 Hex Bolt, (1) M8 Flat Washer and (1) M8 Lock Washer. Next, secure the bracket to the lower threaded hole with (1) M8X1.25-30 Hex Bolt, (1) M8 Flat Washer and (1) M8 Lock Washer. Do not fully tighten hardware at this time.

Repeat to Install the Driver Center and Rear Mounting Brackets.

Models without threaded stud:

- (1) M8X1.25-30 Hex Bolt
- (1) M8 Flat Washer
- (1) M8 Lock Washer

(1) M8X1.25-30 Hex Bolt

- (1) M8 Flat Washer
- (1) M8 Lock Washer

Models with threaded stud:

- (1) M8 Flat Washer
- (1) M8 Nylon Lock Nut

(1) M8X1.25-30 Hex Bolt

- (1) M8 Flat Washer
- (1) M8 Lock Washer

(Fig 3) Driver Front Mounting Bracket Installed

STEP 4

Once all (3) driver side mounting brackets are installed, select and attach the Driver Side Step Bar onto the Mounting Brackets with (6) M6X1-20 T-Bolts, (6) M6 Large Flat Washers and (6) M6X1 Nylon Lock Nuts, (**Fig 4**). Do not tighten hardware at this time.

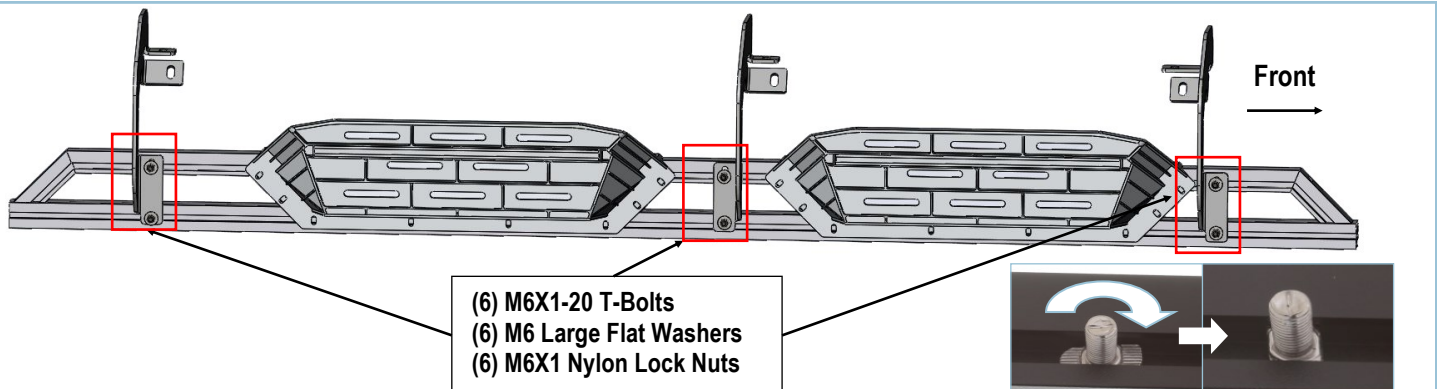

(Fig 4) Driver Side Step Bar Installation

Customer Support: info@iarmorauto.com

iArmor®

STEP 5

Level and adjust the step bar properly and tighten all hardware.

STEP 6

Move to the passenger side of the vehicle. Repeat **steps 1-5** to install the passenger side step bar.

Attention

Do periodic inspections to the installation to make sure that all hardware is secure and tight.

In order to protect your bars/boards, please use only mild soap/non-abrasive products for cleaning.