

iArmor®

IARMOR EDGE™

PART#: IA-N277

BEFORE INSTALLATION

REMOVE CONTENTS FROM BOX. VERIFY ALL PARTS ARE PRESENT. READ INSTRUCTIONS CAREFULLY BEFORE STARTING INSTALLATION. ASSISTANCE IS RECOMMENDED. THANK YOU FOR CHOOSING OUR PRODUCT!

Torque Value

Fastener Size	Tightening Torque (ft-lbs)
6mm	6-7
8mm	16-18
10mm	31-32
12mm	56-58
14mm	92-94

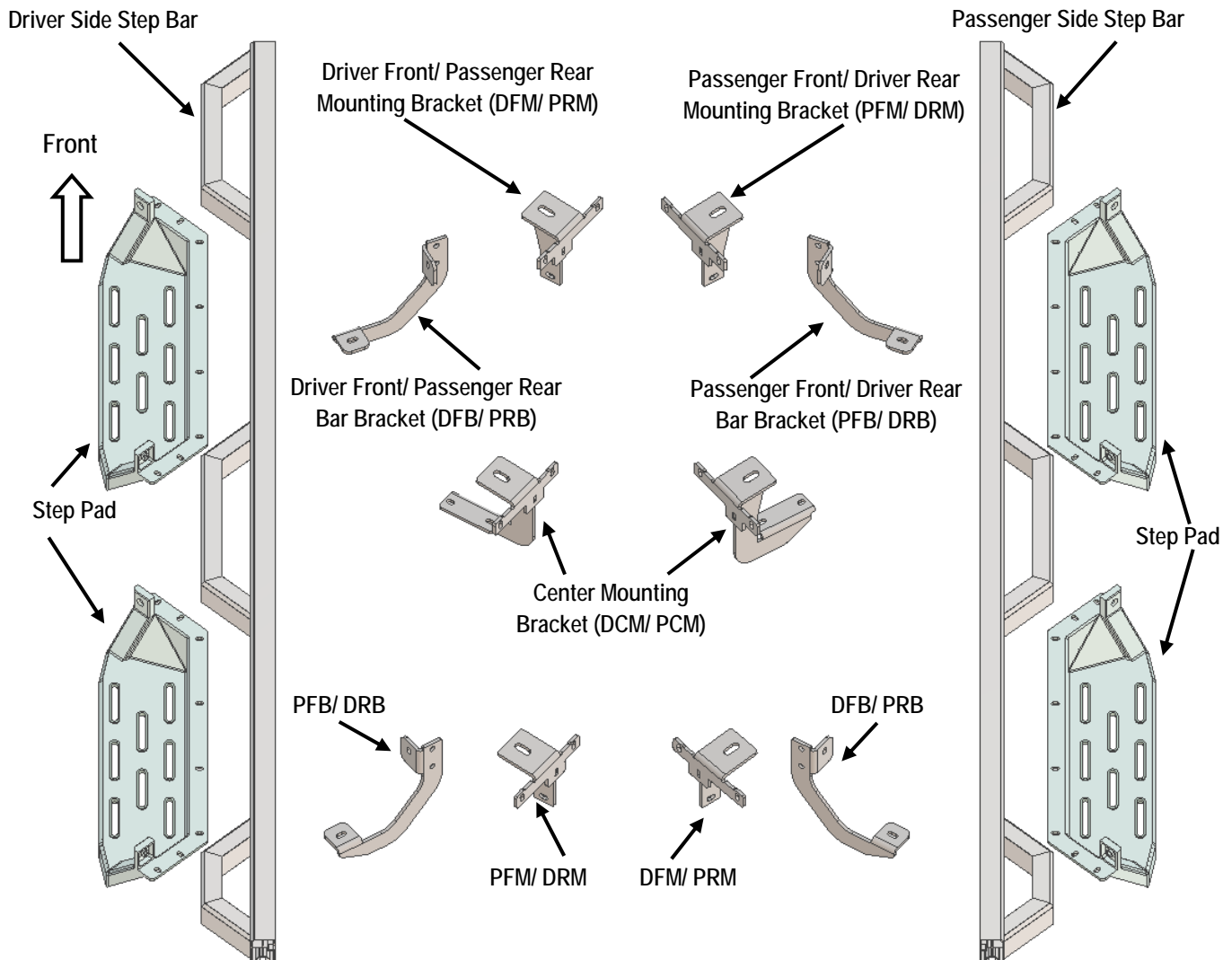

Customer Support: info@iarmorauto.com

iArmor®

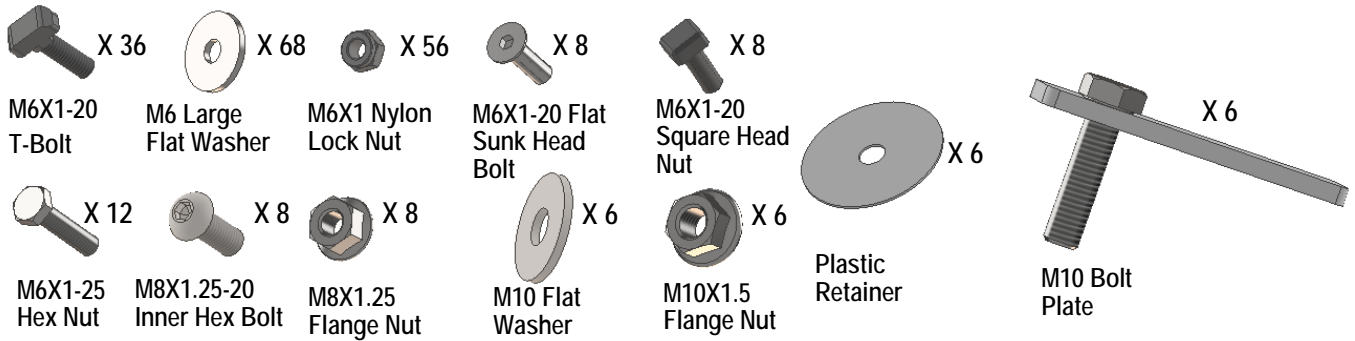

The instruction here is for your reference only. We strongly recommend the professional installer for best result. We are not responsible for any damage caused by the installation.

STEP 1

Install the Step Pads onto the step bars with (32) M6X1-20 T-Bolts, (32) M6 Large Flat Washers, (32) M6X1 Nylon Lock Nuts and (8) M6X1-20 Flat Sunk Head Bolts.

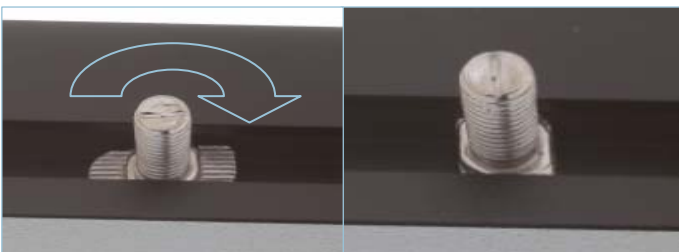

STEP 2

Start at the vehicle passenger side, locate the 3 pairs of (2) small holes in the pinch weld, (Fig 1). Remove the rubber plug filling the oval hole in the bottom of the rocker panel directly in front of the (2) holes, (Fig 2).

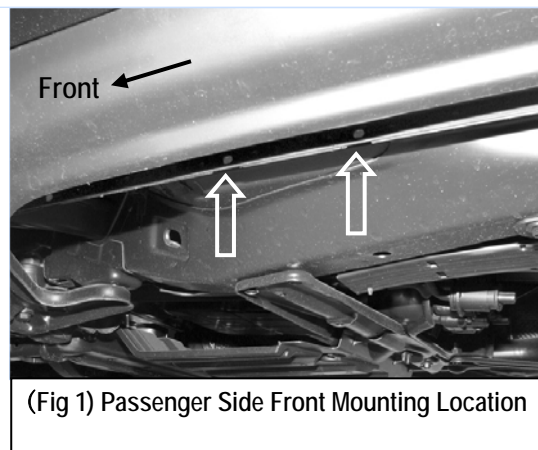

Customer Support: info@iarmorauto.com

iArmor[®]

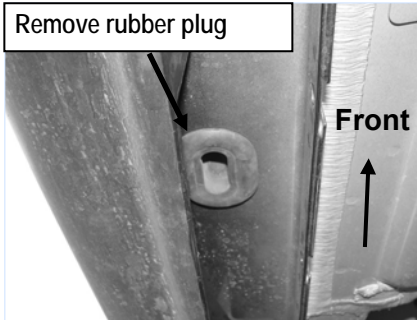

(Fig 2) Remove The Rubber Plug on The Bottom of The Rocker Panel

STEP 3

Select (1) M10 Bolt Plate and (1) Plastic Retainer. Thread the Plastic Retainer part way onto the Bolt Plate. **NOTE:** The Retainer will help hold the Bolt Plate in position during Bracket installation. Insert the Bolt Plate into the oval hole and rotate 90-degrees to the slot, (Fig 3 & 4). Thread the Retainer down until it is tight against the sheet metal.

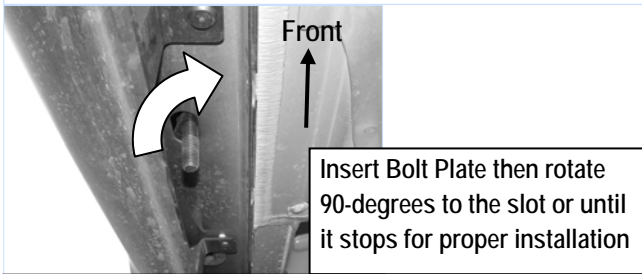

(Fig 3) Insert M10 Bolt Plate

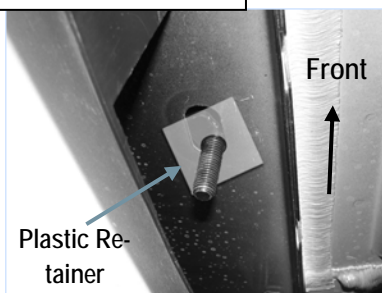

(Fig 4) Thread Plastic Retainer onto Bolt Plate

STEP 4

Select (1) Passenger Front Mounting Bracket (PFM/ DRM), attach it to the Bolt Plate with (1) M10 Flat Washer and (1) M10X1.5 Flange Nut, (Fig 5). Next, bolt the Bracket to the pinch weld with (2) M6X1-25 Hex Bolts, (4) M6 Large Flat Washers and (2) M6X1 Nylon Lock Nuts, (Fig 5). **NOTE:** Insert M6 Hex Bolts with Flat Washers through the back of the pinch weld first, and then out through the Bracket. **IMPORTANT:** The passenger side of the vehicle may have a wiring harness attached behind the pinch weld, (Fig 6). Remove the hex nuts and drop the harness down before installing the Brackets. Install M6 Hex Bolts from the inside, then through the Bracket to clear the harness. Snug but do not fully tighten hardware at this time.

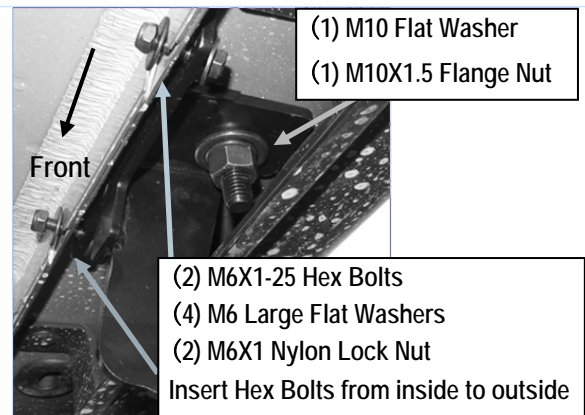

(Fig 5) Passenger Front Mounting Bracket Installation

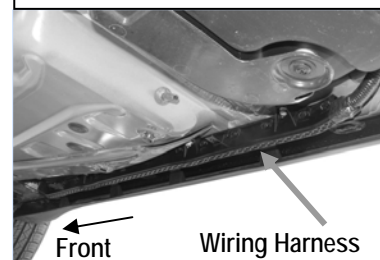

(Fig 6) Passenger Side Wiring Harness

iArmor®

STEP 5

Select (1) Passenger Front Bar Bracket (**PFB/DRB**), and attach it to the installed Passenger Front Mounting Bracket with (2) M8X1.25-20 Inner Hex Bolts, and (2) M8X1.25 Flange Nuts. (**Fig 7**). Leave hardware loose at this time

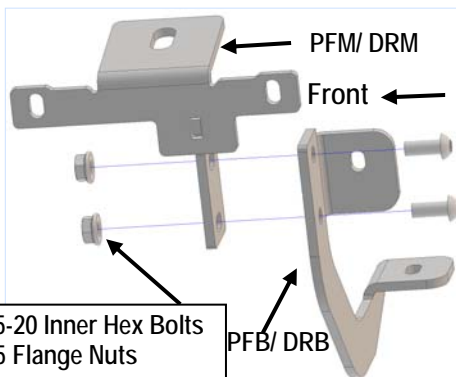

(Fig 7) Passenger Front Bar Bracket Installation

STEP 6

Move to the passenger side center, repeat **Step 2 to 4** to install the Passenger Center Mounting Bracket (**DCM/ PCM**). Do not tighten hardware at this time.

STEP 7

Move forward to the passenger side rear, repeat **Step 2 to 5** to install the Passenger Rear Mounting Bracket (**DFM/ PRM**) and Passenger Rear Bar Bracket (**DFB/ PRB**). Do not tighten hardware at this time.

STEP 8

Attach the assembled Passenger Side Bar to the Mounting Brackets with (2) M6X1-20 T-Bolts, (4) M6X1-20 Square Head Bolts, (6) M6 Large Flat Washers and (6) M6X1 Nylon Lock Nuts, (**Fig 8**). Do not tighten hardware at this time.

STEP 9

Level and adjust the Bar properly and tighten all hardware. NOTE: Torque all M6X1 nylon lock nuts to 7 lb-ft.

STEP 10

Repeat **Steps 2—9** for driver side step bar installation.

STEP 11

Do periodic inspections to the installation to make sure that all hardware is secure and tight.

iArmor®

Attention

In order to protect your bars/boards, please use only mild soap/non-abrasive products for cleaning.

