

IARMOR EDGE™

PART#: IA-W084

BEFORE INSTALLATION

REMOVE CONTENTS FROM BOX. VERIFY ALL PARTS ARE PRESENT. READ INSTRUCTIONS CAREFULLY BEFORE STARTING INSTALLATION. ASSISTANCE IS RECOMMENDED. THANK YOU FOR CHOOSING OUR PRODUCT!

***BODY FRAME MOUNT**

***DRILLING/TRIMMING NOT REQUIRED**

Torque Value

Fastener Size	Tightening Torque (ft-lbs)	Required
6mm	6-7	X
8mm	16-18	X
10mm	31-32	√
12mm	56-58	X
14mm	92-94	X

PART LIST

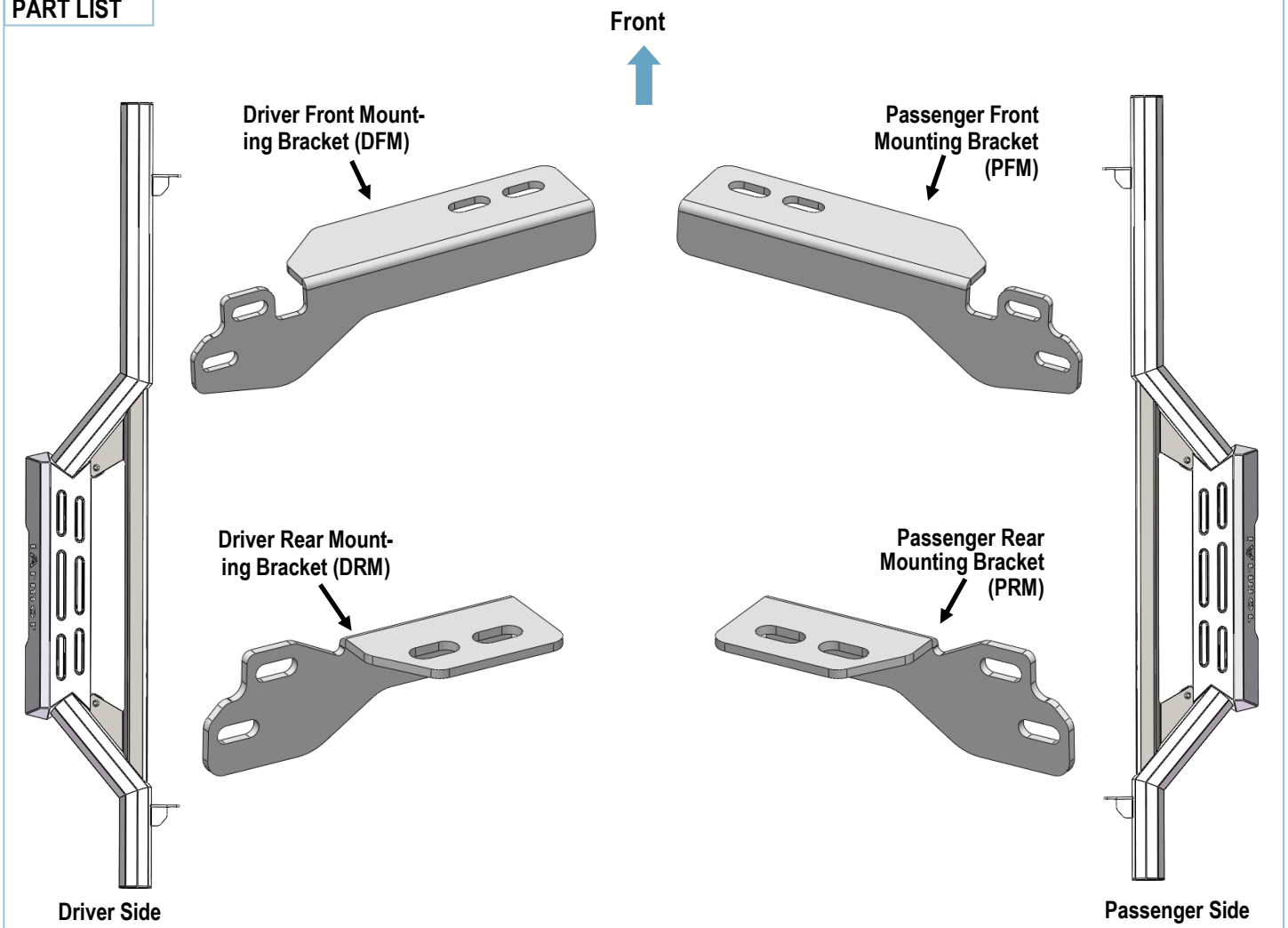

iArmor[®]

Hardware Package (For Brackets & Step Bars Installation)

Item	QTY	Description	Item	QTY	Description
1#	8	M10X1.5-25 Hex Bolts	3#	8	M10X1.5 Nylon Lock Nuts
2#	16	M10 Flat Washers			



1#



2#



3#

iArmor®

The instruction here is for your reference only. We strongly recommend the professional installer for best result. We are not responsible for any damage caused by the installation.

STEP 1

Start installation from the front of the driver side of the vehicle. Remove the factory body mount bolt, **(Fig 1)**. Select Driver Front Mounting Bracket. Insert the factory body mount bolt through the appropriate slot of the mounting bracket, the rubber bushing and back into the vehicle.

NOTE: Do not remove the rubber bushing. The Mounting Bracket will install over the rubber bushing.

IMPORTANT: The Brackets are equipped with (2) mounting slots.

Determine correct model/year for proper installation **(Fig 2)**:

- a. 1987 - 1995 Vehicles: Use the inner slot. Do not tighten hardware at this time.
- b. 1997 - 2006 Vehicles: Use the outer slot. Do not tighten hardware at this time.

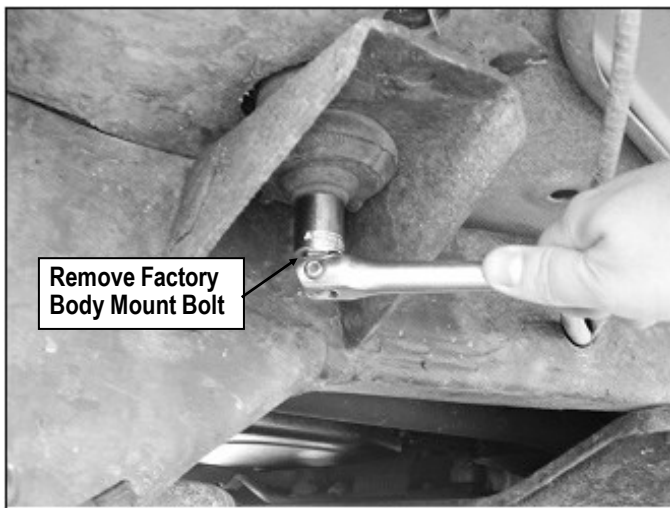

(Fig 1) Remove Factory Body Mount Bolt

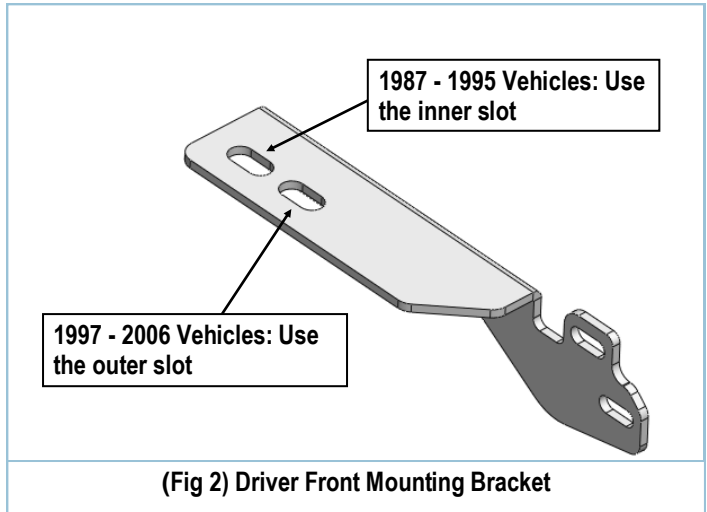

(Fig 2) Driver Front Mounting Bracket

STEP 2

Repeat **Step 1** for the driver side rear bracket installation.

STEP 3

Once all (2) Brackets have been installed, attach the Driver Side Bar to the Bar Brackets with (4) M10X1.5-25 Hex Bolts, (8) M10 Flat Washers and (4) M10X1.5 Nylon Lock Nuts, **(Fig 3)**. Do not fully tighten hardware at this time.

Properly level and adjust the Step Bar and fully tighten all hardware.

STEP 4

Move to the other side of the vehicle. Repeat **Steps 1-3** for the other side step bar installation.

Attention

Do periodic inspections to the installation to make sure that all hardware is secure and tight.

In order to protect your bars/boards, please use mild soap/non-abrasive products for cleaning only.

iArmor[®]

