

# iArmor®

## IARMOR EDGE™

PART#: IA-W115

### BEFORE INSTALLATION

REMOVE CONTENTS FROM BOX. VERIFY ALL PARTS ARE PRESENT. READ INSTRUCTIONS CAREFULLY BEFORE STARTING INSTALLATION. ASSISTANCE IS RECOMMENDED. THANK YOU FOR CHOOSING OUR PRODUCT!

\*ROCKER PANEL MOUNT

\*DRILLING/TRIMMING NOT REQUIRED

### Torque Value

| Fastener Size | Tightening Torque (ft-lbs) | Required |
|---------------|----------------------------|----------|
| 6mm           | 6-7                        | √        |
| 8mm           | 16-18                      | √        |
| 10mm          | 31-32                      | √        |
| 12mm          | 56-58                      | X        |
| 14mm          | 92-94                      | X        |

### PART LIST

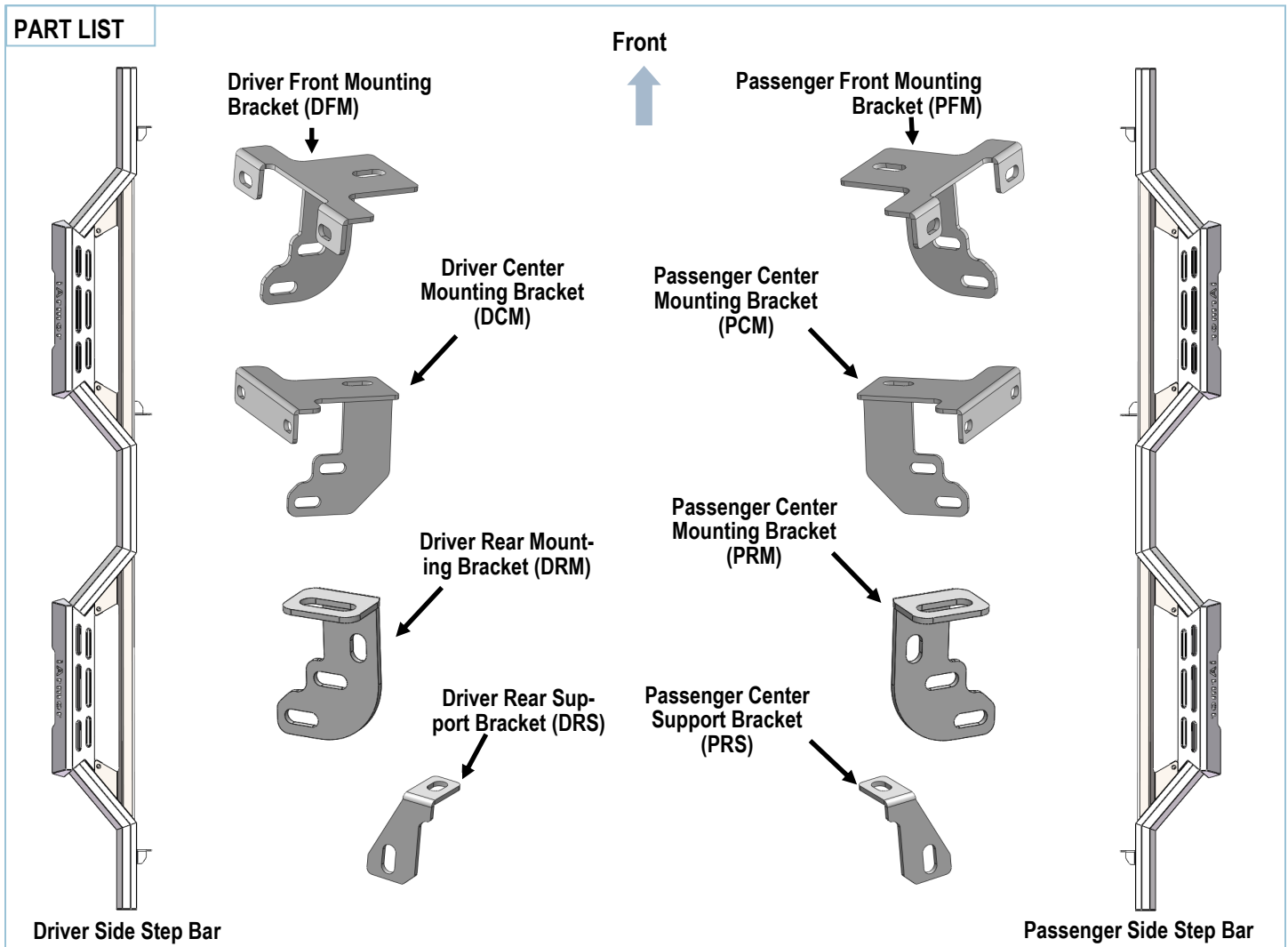











Customer Support: [info@iarmorauto.com](mailto:info@iarmorauto.com)

# iArmor<sup>®</sup>

| Hardware Package (For Brackets & Step Bars Installation) |     |                       |      |     |                       |
|--|-----|-----------------------|------|-----|-----------------------|
| Item   | QTY | Description           | Item | QTY | Description           |
| 1#   | 8   | M8X1.25-35 Hex Bolts  | 7#   | 20  | M6 Large Flat Washers |
| 2#   | 6   | M8 Large Flat Washers | 8#   | 10  | M6X1 Nylon Lock Nuts  |
| 3#   | 4   | M8 Flat Washers       | 9#   | 12  | M10X1.5-25 Hex Bolts  |
| 4#   | 6   | M8 Lock Washers       | 10#  | 24  | M10 Flat Washers      |
| 5#   | 2   | M8 Nylon Lock Washers | 11#  | 12  | M10 Nylon Lock Nuts   |
| 6#   | 10  | M6X1-25 Hex Bolts     |      |     |                       |

|   |   |   |   |   |   |
|---|---|---|---|---|---|
|    |    |    |      |    |  |
| 1#  | 2#  | 3#  | 4#  | 5#  | 6#  |
|  |  |  |  |  |   |
| 7#  | 8#  | 9#  | 10#   | 11#   |   |

# iArmor<sup>®</sup>

The instruction here is for your reference only. We strongly recommend the professional installer for best result. We are not responsible for any damage caused by the installation.

## STEP 1

Starting from the Passenger side front of the vehicle. Locate the factory threaded mounting holes in the bottom of the floor, (Fig 1).

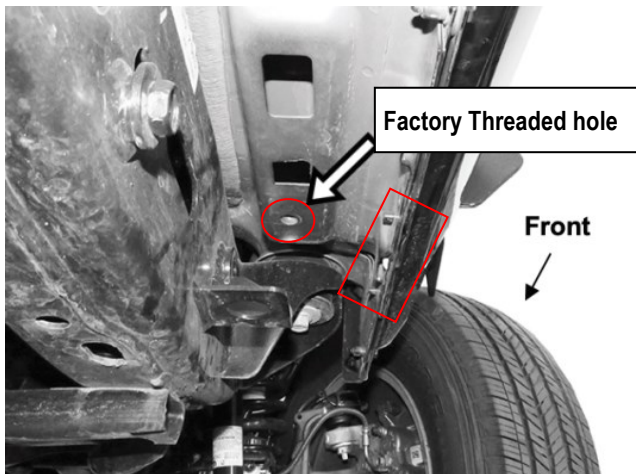

(Fig 1) Passenger Side Front Mounting Location

## STEP 2

Select the Passenger Front Mounting Bracket (PFM). Attach the top of the bracket to the factory threaded hole using the included (1) M8X1.25-35 Hex Bolt, (1) M8 Lock Washers and (1) M8 Large Flat Washer. Attach the lower (2) holes to the pinch weld with (2) M6X1-25 Hex Bolts, (4) M6 Flat Washers and (2) M6 Nylon Lock Nuts, (Fig 2). Do not fully tighten hardware at this time.

(2) M6X1-25 Hex Bolts  
(4) M6 Large Flat Washers  
(2) M6X1 Nylon Lock Nuts

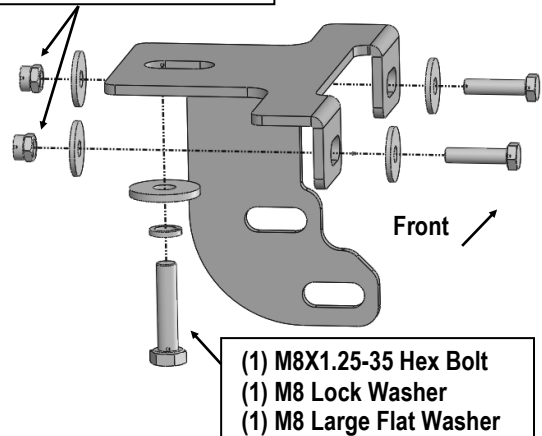

(Fig 2) Passenger Front Mounting Bracket Installation

## STEP 3

Move to the passenger side center mounting location, (Fig 3). Repeat Step 2 to install the Passenger Center Mounting Bracket (PCM), (Fig 4). Do not fully tighten hardware at this time.

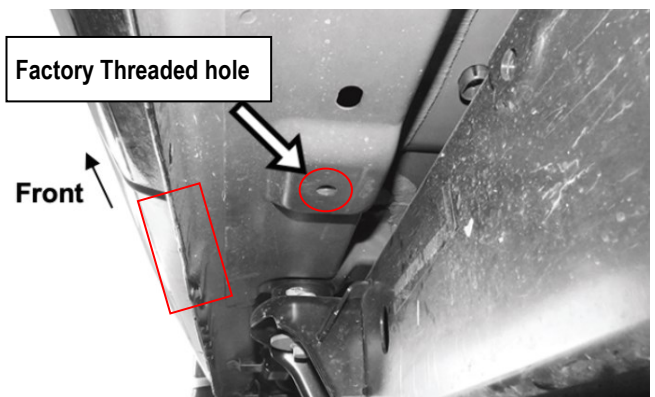

(Fig 3) Passenger Side Center Mounting Location

# iArmor®

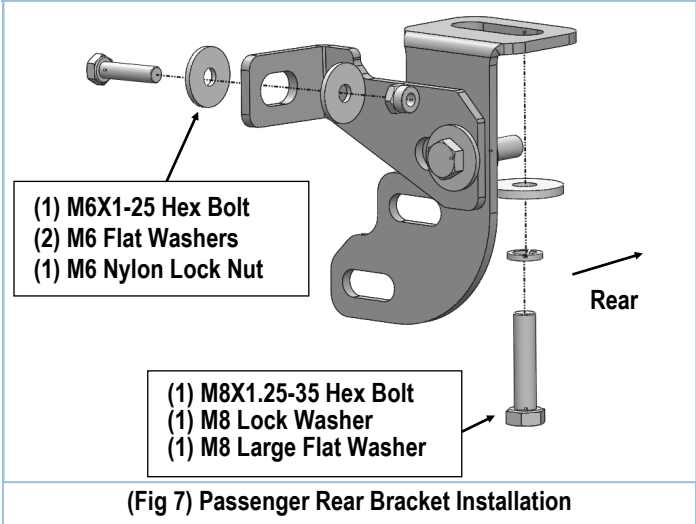
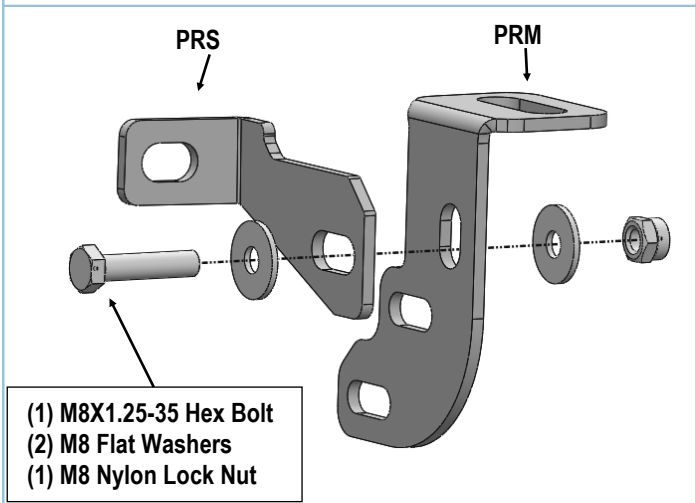
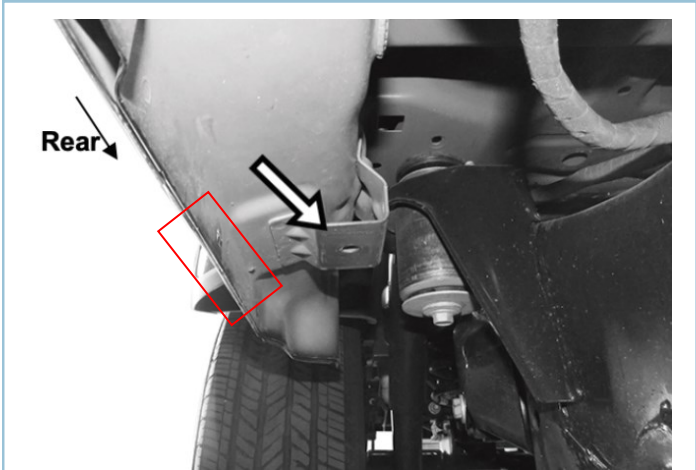
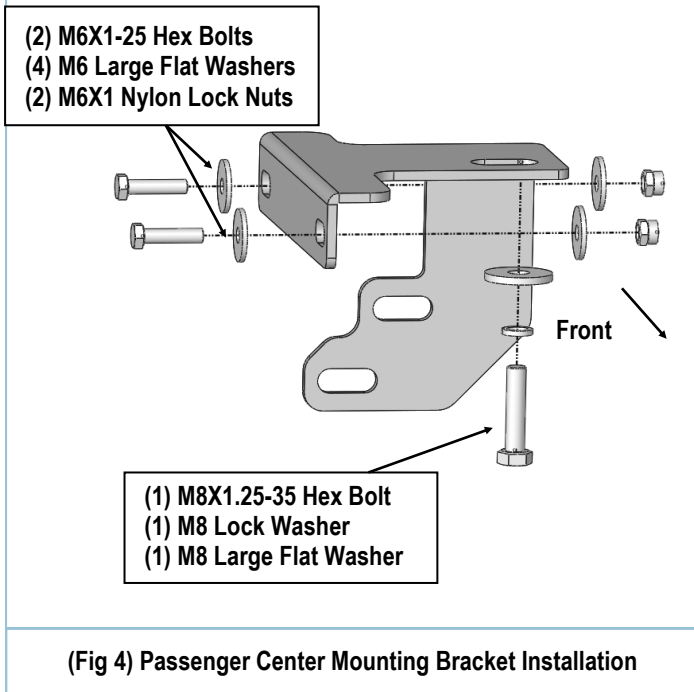

## STEP 4

Continue to the rear mounting location (Fig 5). Assemble Passenger Rear Mounting Bracket (PRM) and Passenger Rear Support Bracket (PRS) with (1) M8X1.25-35 Hex Bolt, (2) M8 Flat Washers and (1) M8 Nylon Lock Nut, (Fig 6).

Attach the top of the Assembled Passenger Rear Mounting Bracket to the threaded hole at the bottom of the floor panel with (1) M8X1.25-35 Hex Bolt, (1) M8 Lock Washer and (1) M8 Flat Washer (Fig 7). Secure the Passenger Rear Support Bracket (PRS) on the pinch weld with (1) M6X1-25 Hex Bolt, (2) M6 Flat Washers and (1) M6 Nylon Lock Nut. Leave hardware loose at this time.

# iArmor<sup>®</sup>

## STEP 5

Once all (3) Mounting Brackets have been installed, attach the Passenger Side Step Bar to the Mounting Brackets using (6) M10X1.5-25 Hex Bolts, (12) M10 Flat Washers and (6) M10X1.5 Nylon Lock Nuts, (**Fig 8**). Do not fully tighten hardware at this time.

## STEP 6

Properly level and adjust the Step Bar and fully tighten all hardware.

## STEP 7

Move to the other side of the vehicle. Repeat **Steps 1-6** for the other Side Step Bar installation.

### Attention

Do periodic inspections to the installation to make sure that all hardware is secure and tight.

In order to protect your bars/boards, please use mild soap/non-abrasive products for cleaning only.

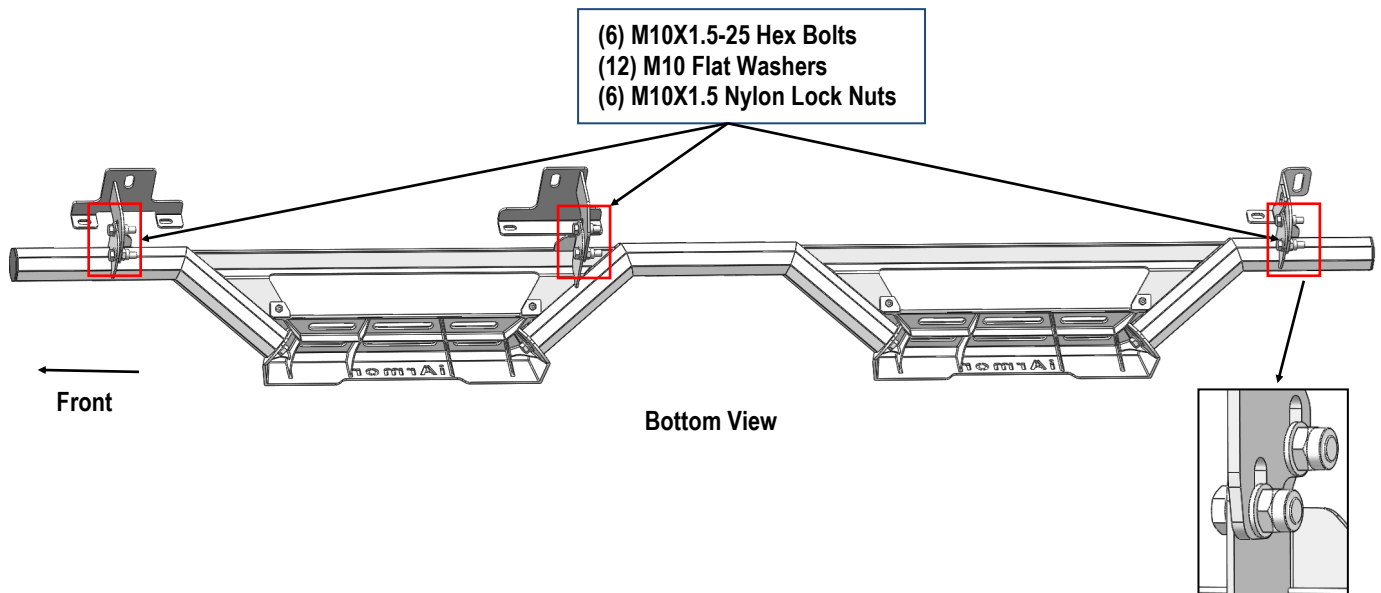

(Fig 8) Passenger Side Step Bar Installed