

iArmor[®]

iArmor[®] by APS

PART#: IA-S093H

BEFORE INSTALLATION

REMOVE CONTENTS FROM BOX. VERIFY ALL PARTS ARE PRESENT. READ INSTRUCTIONS CAREFULLY BEFORE STARTING INSTALLATION. ASSISTANCE IS RECOMMENDED. THANK YOU FOR CHOOSING OUR PRODUCT!

***ROCKER PANEL MOUNT**

***NO DRILLING / TRIMMING REQUIRED**

Torque Value

Fastener Size	Tightening Torque (ft-lbs)	Required
6mm	6-7	X
8mm	16-18	√
10mm	31-32	X
12mm	56-58	√
14mm	92-94	X

PART LIST

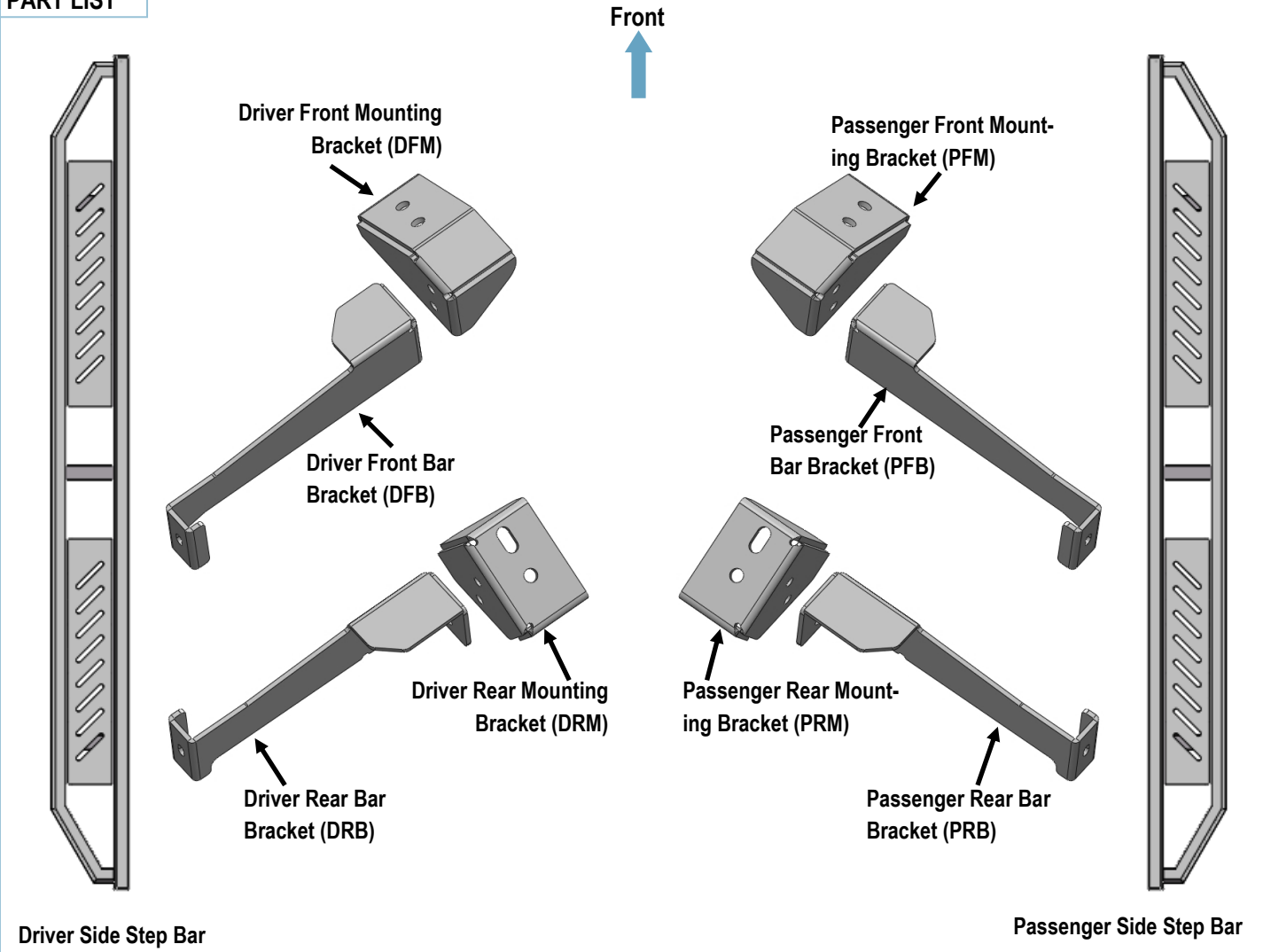

Customer Support: info@iarmorauto.com

iArmor®

Hardware Package A (For Bracket Installation)					
Item	QTY	Description	Item	QTY	Description
1#	4	U Brackets	6#	8	M10X1.5-30mm Hex Bolts
2#	4	Backing Plates	7#	16	M10 Large Flat Washers
3#	8	M12X1.75-30mm Hex Bolts	8#	8	M10 Lock Washers
4#	8	M12 Large Flat Washers	9#	8	M10 Hex Nuts
5#	8	M12 Lock Washers			

1# 2# 3# 4# 5# 6# 7# 8# 9#

Hardware Package B (For Step Bar Installation)					
Item	QTY	Description	Item	QTY	Description
1#	4	M8X1.25-55mm Carriage Bolts	3#	4	M8 Lock Washers
2#	4	M8 Large Flat Washers	4#	4	M8 Hex Nuts

1# 2# 3# 4#

iArmor®

The instruction here is for your reference only. We strongly recommend the professional installer for best result. We are not responsible for any damage caused by the installation.

STEP 1

Start installation on the front, driver side of the vehicle. Assemble the Driver Front Mounting Bracket (DFM) and Driver Front Bar Bracket (DFB), with (2) M10X1.5-30mm Hex Bolts, (4) M10 Large Flat Washers, (2) M10 Lock Washers and (2) M10 Hex Nuts, (Fig 1). Do not fully tighten hardware at this time.

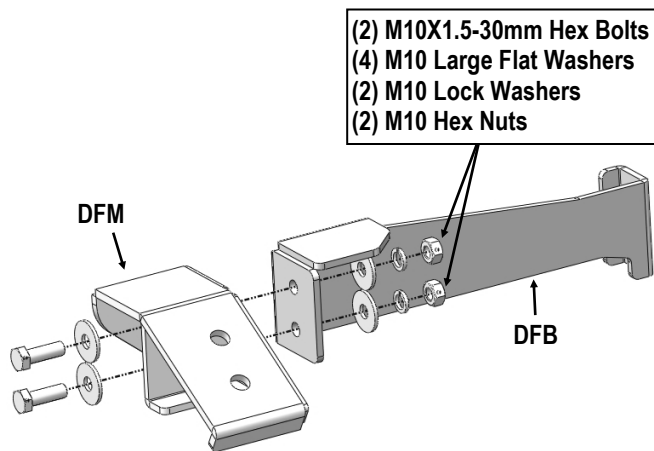

(Fig 1) Driver Side Front Brackets Assembly

STEP 2

Select (1) Backing Plate and place it behind the body frame, line up the holes, clamp (1) Driver Front Mounting Bracket (DFM) on the other side using (2) M12x1.75-30mm Hex Bolts (2) M12 Lock Washers and (2) M12 Large Flat Washers to the front body mounting position. Do not fully tighten hardware at this time, (Fig 2-3).

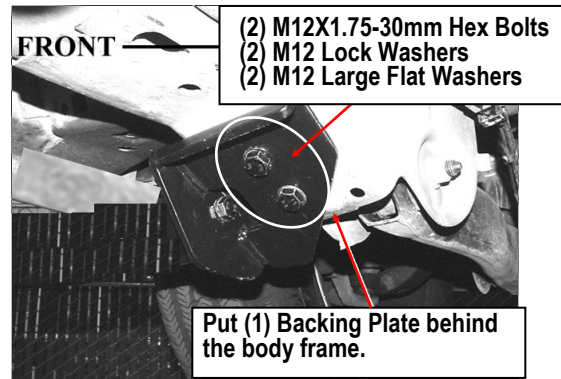

(Fig 2) Assembled Driver Front Mounting Bracket Installed

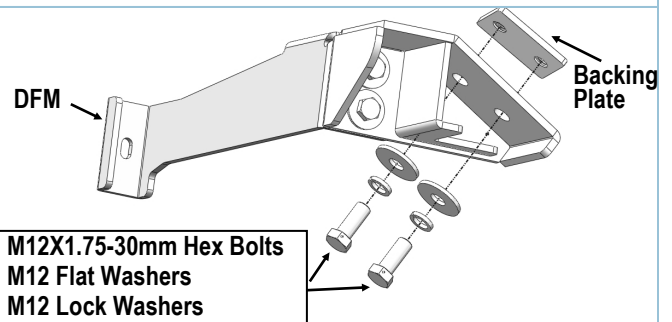

(Fig 3) Exploded View of Driver Front Mounting Bracket Installation

STEP 3

Move toward the rear of the vehicle. Assemble the Driver Rear Mounting Bracket (DRM) and Driver Rear Bar Bracket (DRB) with (2) M10X1.5-30mm Hex Bolts, (4) M10 Large Flat Washers, (2) M10 Lock Washers and (2) M10 Hex Nuts, (Fig 4). Do not fully tighten hardware at this time.

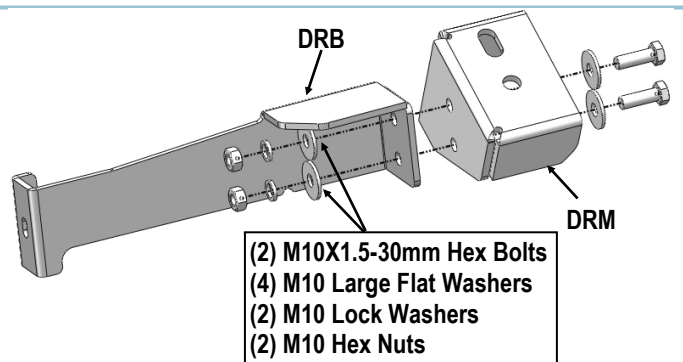

(Fig 4) Driver Side Rear Brackets Assembly

iArmor®

STEP 4

Repeat **Step 2** to install the Assembled Driver Rear Mounting Bracket. Do not fully tighten hardware at this time, (**Fig 5-6**).

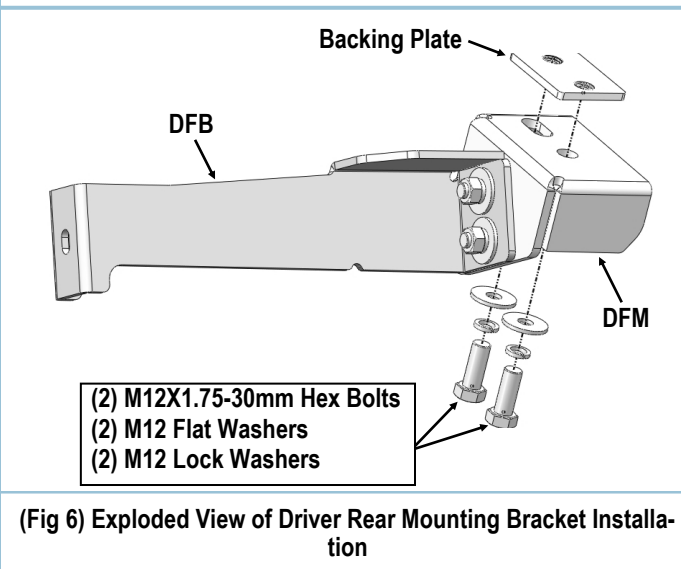
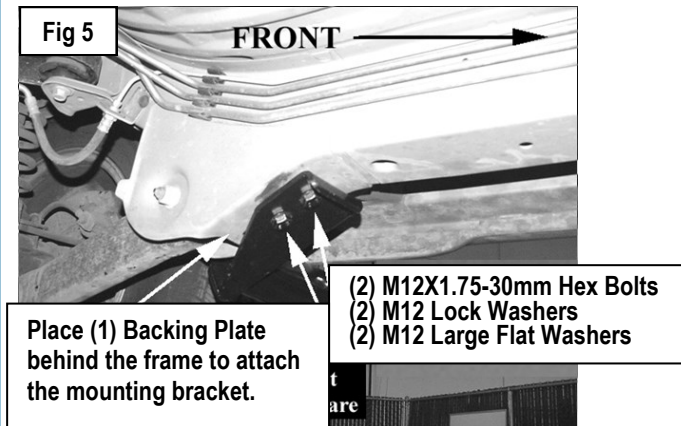

STEP 5

Once all (2) driver side mounting brackets are installed, select and attach the Driver Side Step Bar onto the Mounting Brackets with (2) U Brackets, (2) M8X1.25-55mm Carriage Bolts, (2) M8 Large Flat Washers, (2) M8 Lock Washers and (2) M8X1.25 Hex Nuts, (**Fig 7**). Do not fully tighten hardware at this time.

STEP 6

Properly level and adjust the Step Bar and fully tighten all hardware.

STEP 7

Move to the passenger side of the vehicle. Repeat **Steps 1-6** to install passenger side step bar.

Installation completed.

Attention

Do periodic inspections to the installation to make sure that all hardware is secure and tight.

In order to protect your bars/boards, please use mild soap/non-abrasive products for cleaning only.

iArmor[®]

NOTE: Torque all M8 X1.25-55mm Carriage Bolts to 16~18 lb-ft. Don't over tighten, or the square bars will be damaged by the brackets

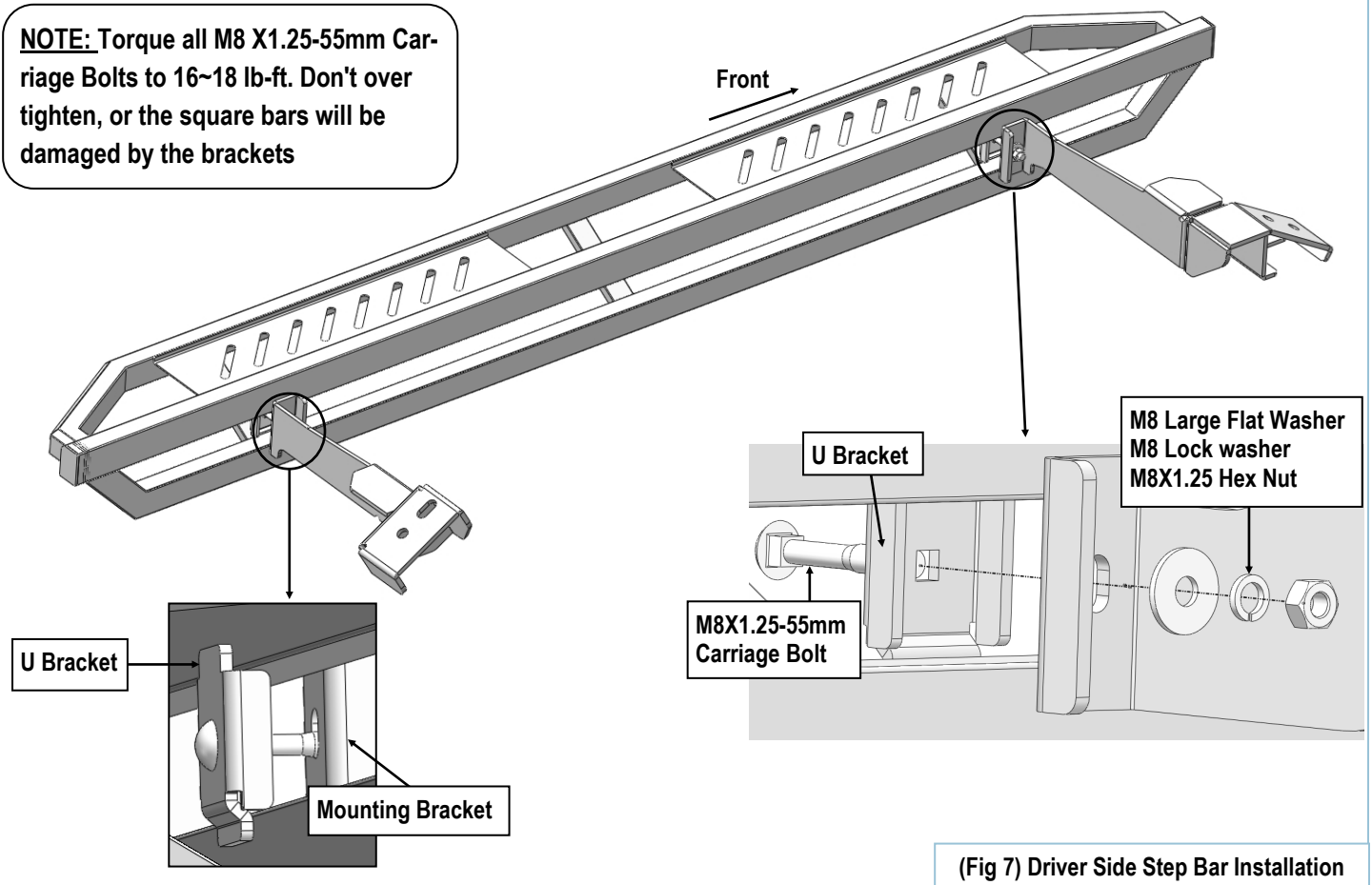

(Fig 7) Driver Side Step Bar Installation