

# iArmor<sup>®</sup>

## iArmor<sup>®</sup> by APS

PART#: IA-S106

### BEFORE INSTALLATION

REMOVE CONTENTS FROM BOX. VERIFY ALL PARTS ARE PRESENT. READ INSTRUCTIONS CAREFULLY BEFORE STARTING INSTALLATION. ASSISTANCE IS RECOMMENDED. THANK YOU FOR CHOOSING OUR PRODUCT!

**\*ROCKER PANEL MOUNT**

**\*NO DRILLING / TRIMMING REQUIRED**

### Torque Value

Fastener Size	Tightening Torque (ft-lbs)	Required
6mm	6-7	√
8mm	16-18	√
10mm	31-32	X
12mm	56-58	X
14mm	92-94	X

### PART LIST

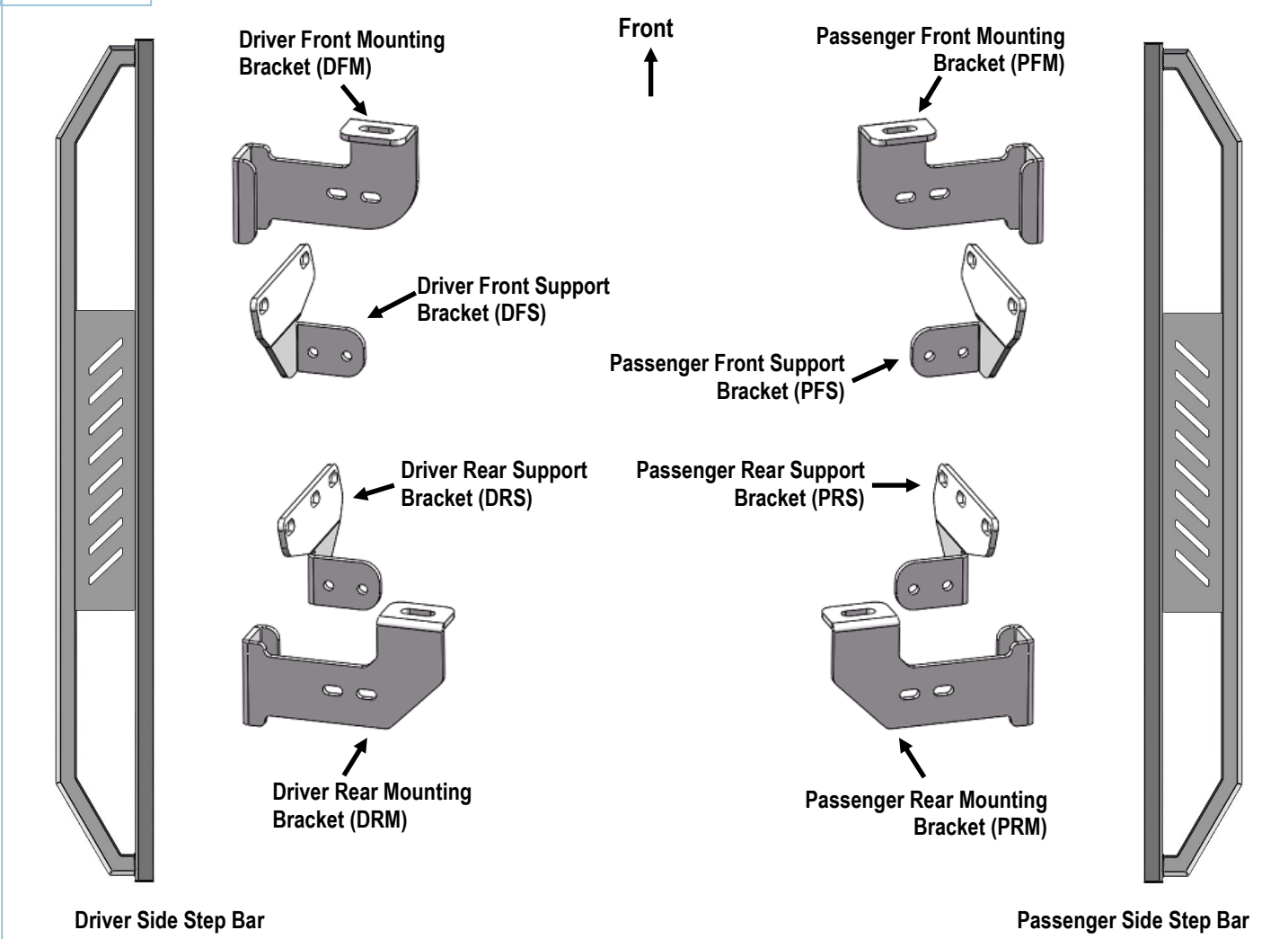

Customer Support: [info@iarmorauto.com](mailto:info@iarmorauto.com)

# iArmor®



The instruction here is for your reference only. We strongly recommend the professional installer for best result. We are not responsible for any damage caused by the installation.

## STEP 1

Start installation toward the front of the driver side of the vehicle. Determine if the vehicle has an open floor panel or a threaded hole in the floor panel for the top tab on the Bracket, (Figs 1 & 2).

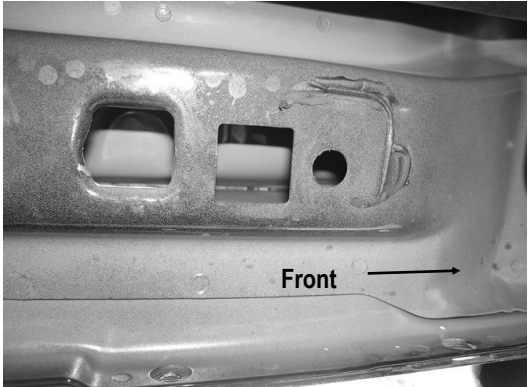

(Fig 1) Driver Side Front Mounting Location (Vehicles with open mounting location)

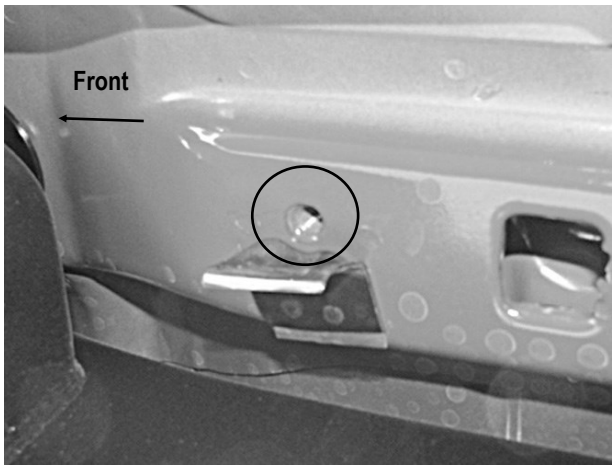

(Fig 2) Driver Side Front Mounting Location (Vehicles with factory threaded hole in floor panel)

## STEP 2

Assemble (2) Driver Side Mounting Brackets and Driver Support Brackets as shown, (Figs 3-4). Do not fully tighten hardware at this time.

# iArmor®

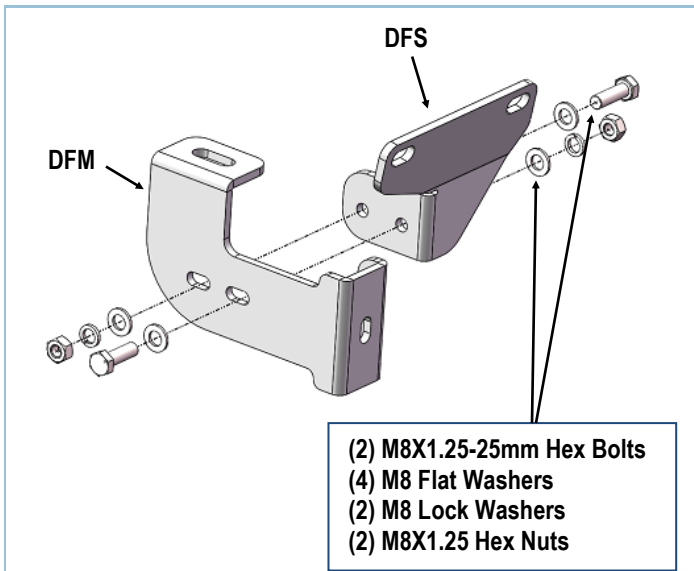

(Fig 3) Driver Front Mounting Bracket Assembly

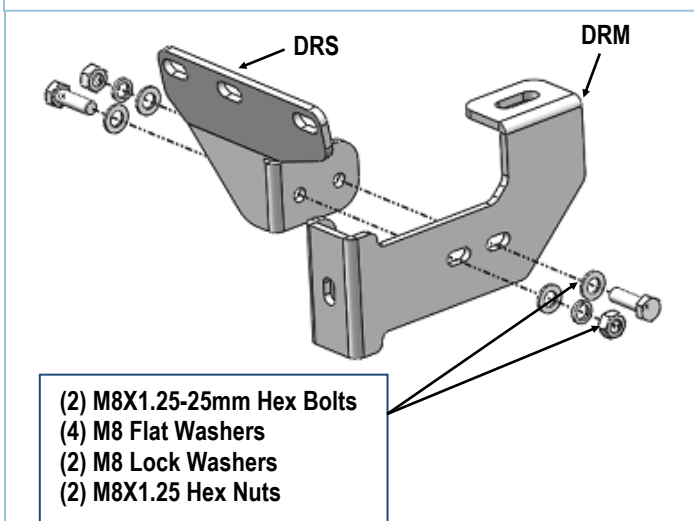

(Fig 4) Driver Rear Mounting Bracket Assembly

## STEP 3

Select the assembled Driver Front Mounting Bracket.

### Vehicles open mounting location:

Insert (1) M8 Nut Plate into the large square opening in the floor panel. Line up the threaded nut with the small hole in line with the tab on the Bracket, (Figs 5A & 5B). Bolt the Mounting

Bracket to the Nut Plate with (1) M8X1.25-35mm Hex Bolt, (1) M8 Lock Washer and (1) M8 Large Flat Washer. Do not fully tighten hardware at this time, (Fig 6).

### Vehicles with factory threaded hole in floor panel:

Bolt the tab on the Mounting Bracket to the threaded hole in the floor panel with (1) M8X1.25-35mm Hex Bolt, (1) M8 Lock Washer and (1) M8 Large Flat Washer, (Figs 6). Do not fully tighten hardware at this time.

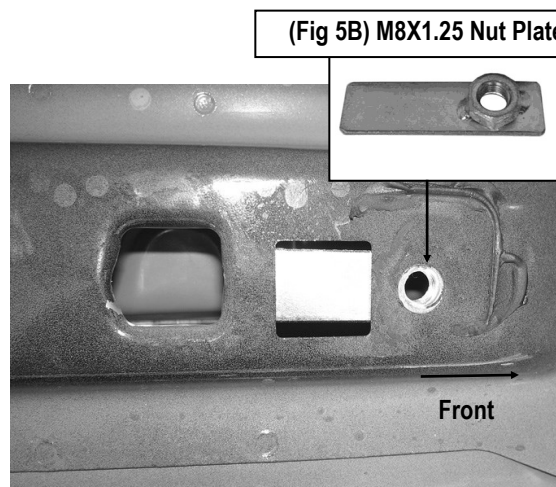

(Fig 5A) Driver Side Front Mounting Location (Vehicles with open mounting location)

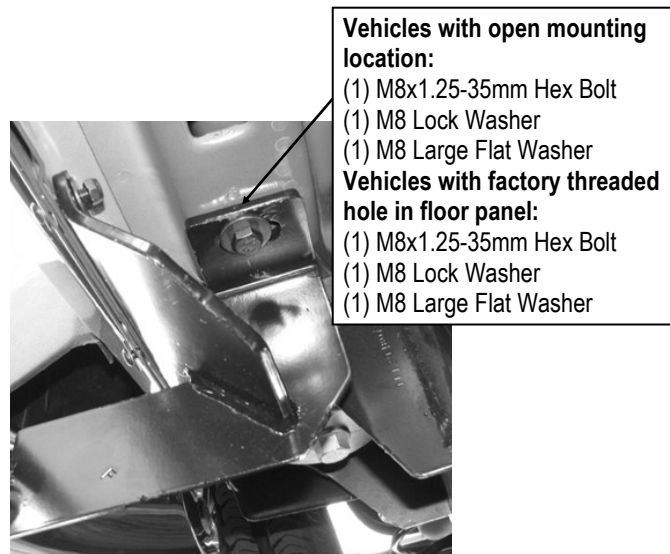

(Fig 6) Driver Front Mounting Bracket Installation

# iArmor®

## STEP 4

Line up the Support Bracket with the (2) factory holes on the pinch weld. Bolt the Support Bracket to the back of the pinch weld using the included (2) M6X1-25mm Inner Hex Bolts, (2) M6 Flat Washers, (against pinch weld), (2) M6 Large Flat Washers, (inside against the bracket) and (2) M6X1 Nylon Lock Nuts, (Fig 7). Do not fully tighten hardware at this time.

(2) M6X1-25mm Inner Hex Bolts  
(2) M6 Flat Washers (against pinch weld)  
(2) M6 Large Flat Washers (inside against the bracket)  
(2) M6X1 Nylon Lock Nuts

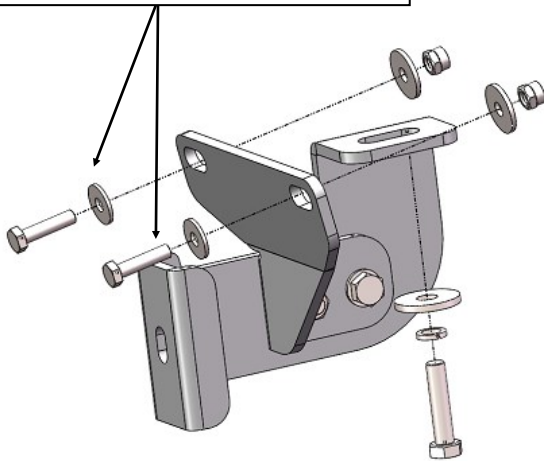

(Fig 7) Driver Front Support Bracket Installation

## STEP 5

Move to the Driver Side Rear Mounting Location, (Fig 8A). Repeat **Steps 1-3** for the assembled Driver Rear Mounting Bracket installation, (Figs 2 & 8B).

**NOTE:** Determine correct Rear Support Bracket installation procedure according to the model year of the vehicle:

**A. 2007 Model:** Line up the center hole on the Support Bracket to the pinch weld, secure by using (1) M6X1-25mm Inner Hex Bolt, (1) M6 Flat Washer (outside), (1) M6 Large Flat Washer, (1) M6X1 Nylon Lock Nut

(inside against bracket), and (1) M6X1 Nylon Lock Nut to attach rear bracket to the back of the pinch weld, (Fig 9).

**B. 2008-UP Models:** Attach the Support Bracket to the back of pinch weld by using (2) M6X1-25mm Inner Hex Bolts, (2) M6 Flat Washers (outside), (2) M6 Large Flat Washers (inside against the bracket) and (2) M6X1 Nylon Lock Nuts, (Fig 10).

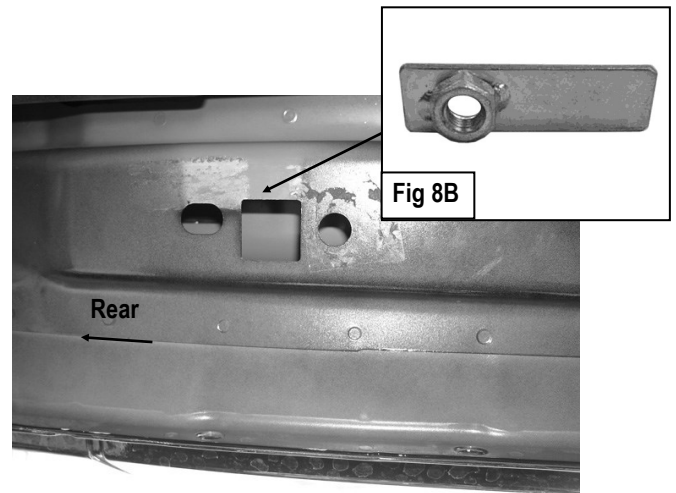

(Fig 8A) Driver Side Rear Mounting Location  
(Vehicles with open mounting location)

2007 model:

(1) M6X1-25mm Inner Hex Bolt  
(1) M6 Flat Washers (outside)  
(1) M6 Large Flat Washer (inside against the bracket)  
(1) M6X1 Nylon Lock Nut

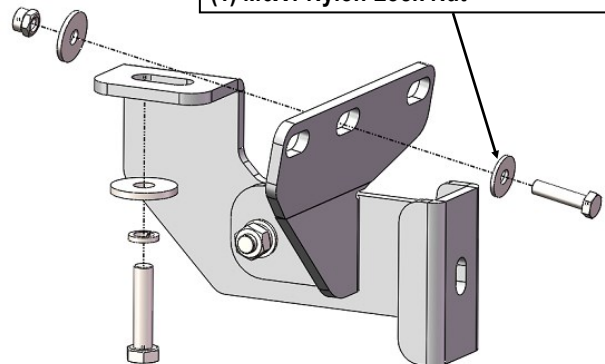

(Fig 9) Driver Rear Support Bracket Installation  
(For 2007 Model Only)

# iArmor®

2008-UP Models:  
(2) M6X1-25mm Inner Hex Bolts  
(2) M6 Flat Washers (outside)  
(2) M6 Large Flat Washers (inside against the bracket)  
(2) M6X1 Nylon Lock Nuts

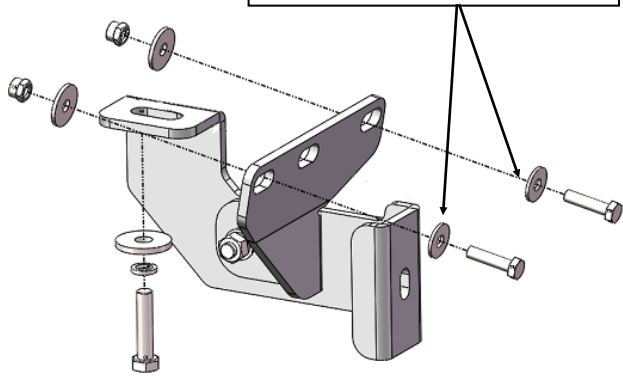

(Fig 10) Driver Rear Support Bracket Installation  
(For 08-UP Models)

## STEP 6

Once all (2) Driver side mounting brackets are installed, select and attach the Driver Side Step Bar onto the Mounting Brackets with (2) U Brackets, (4) Spacers, (2) M8X1.25-55mm Carriage Bolts, (2) M8 Flat Washers, (2) M8 Lock Washers and (2) M8X1.25 Hex Nuts (Fig 11). Do not fully tighten hardware at this time.

Properly level and adjust the Step Bar and fully tighten all hardware.

## STEP 7

Move to the other side of the vehicle. Repeat **Steps 1-6** to install the other side step bar.

**Installation completed.**

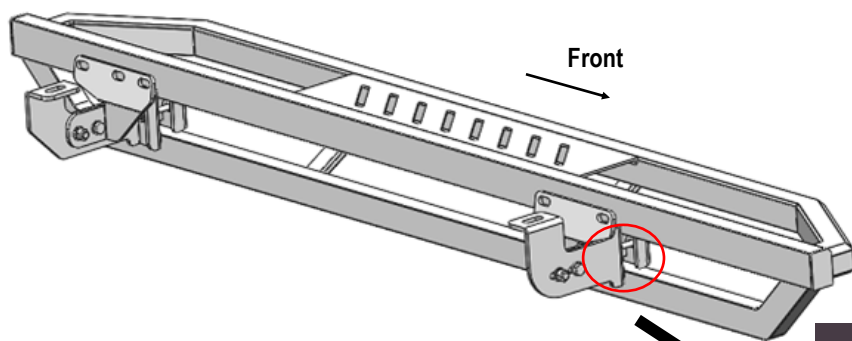

(Fig 11) Driver Side Step Bar Installed

**NOTE:** Torque all M8 X1.25-55mm Carriage Bolts to 16~18 lb-ft. Don't over tighten, or the aluminum square bars will be damaged by the brackets

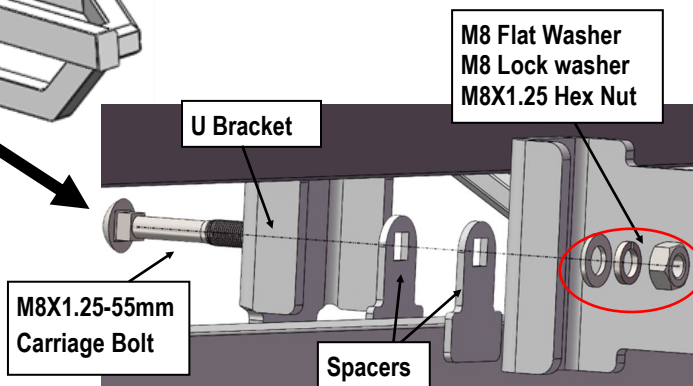

### Attention

Do periodic inspections to the installation to make sure that all hardware is secure and tight. In order to protect your bars/boards, please use only mild soap/non-abrasive products for cleaning.