

iArmor[®]

iArmor[®] by APS

PART#: IA-S116

BEFORE INSTALLATION

REMOVE CONTENTS FROM BOX. VERIFY ALL PARTS ARE PRESENT. READ INSTRUCTIONS CAREFULLY BEFORE STARTING INSTALLATION. ASSISTANCE IS RECOMMENDED. THANK YOU FOR CHOOSING OUR PRODUCT!

***ROCKER PANEL MOUNT**

***NO DRILLING / TRIMMING REQUIRED**

Torque Value

Fastener Size	Tightening Torque (ft-lbs)	Required
6mm	6-7	√
8mm	16-18	√
10mm	31-32	X
12mm	56-58	X
14mm	92-94	X

PART LIST

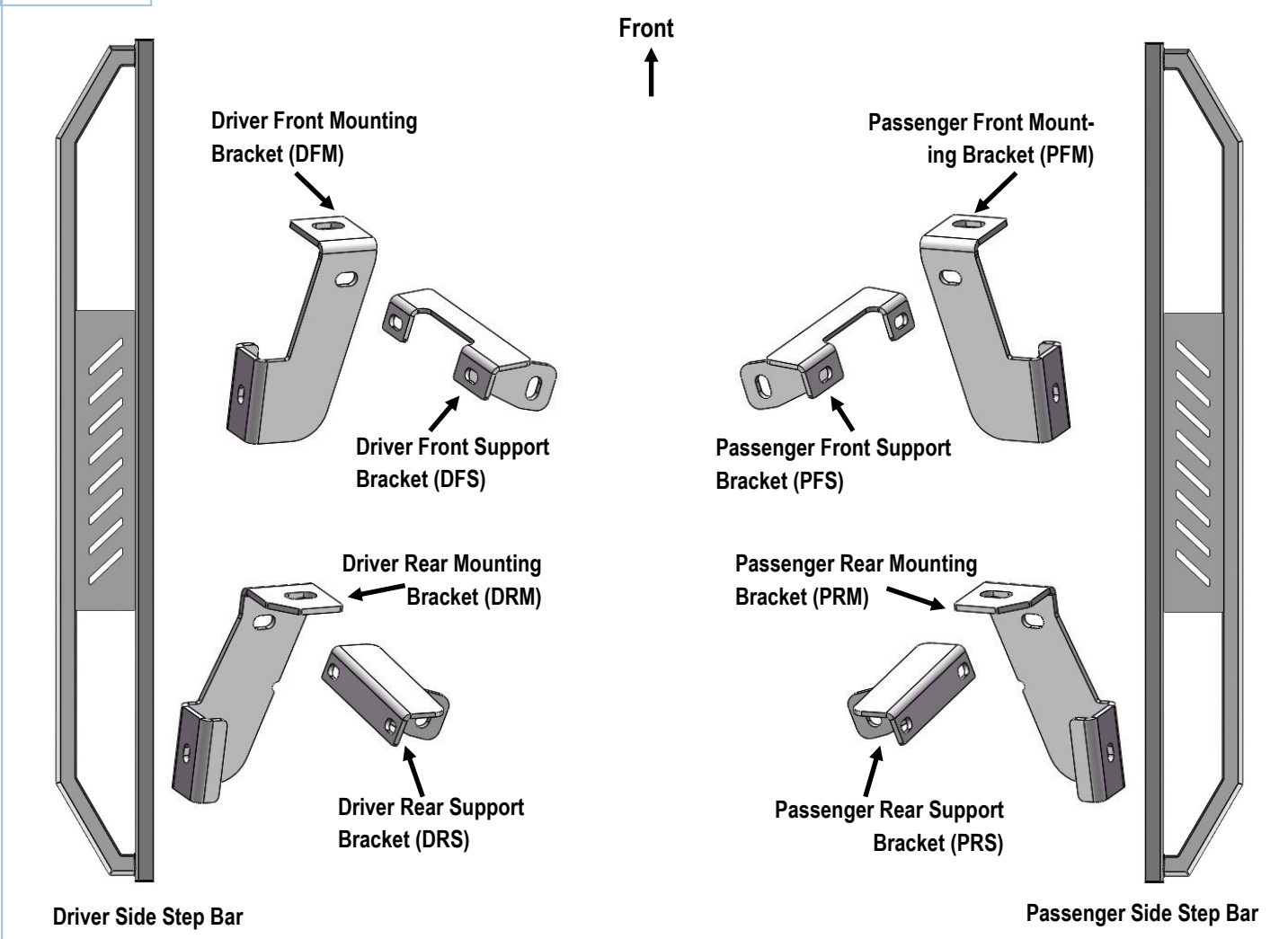

Customer Support: info@iarmorauto.com

iArmor®

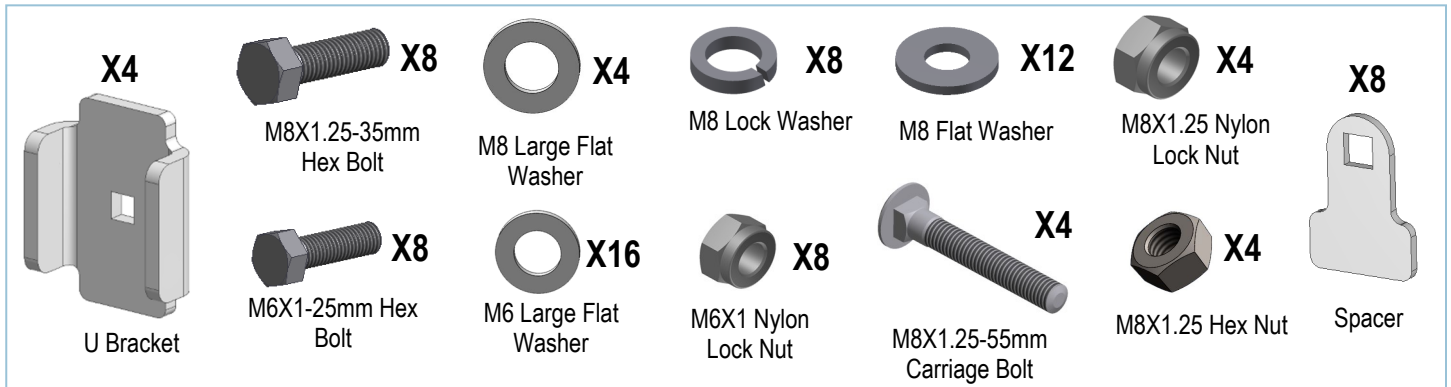

The instruction here is for your reference only. We strongly recommend the professional installer for best result. We are not responsible for any damage caused by the installation.

STEP 1

Start installation from the passenger side front of the vehicle. Assemble the Passenger Front Mounting Bracket (PFM) and Passenger Front Support Bracket (PFS) as shown, (Fig 1). Do not fully tighten hardware at this time.

- (1) M8X1.25-35mm Hex Bolt
- (2) M8 Flat Washers
- (1) M8X1.25 Nylon Lock Nut

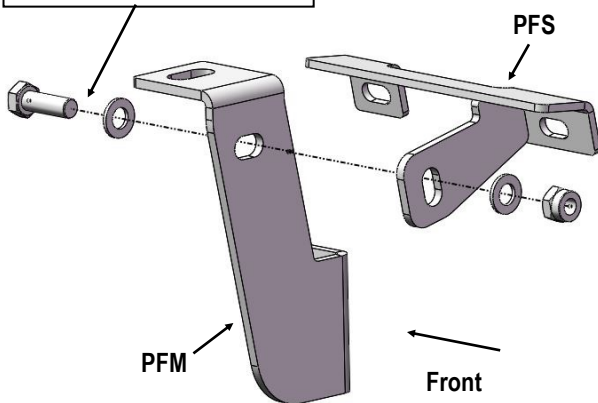

(Fig 1) Passenger Front Mounting Bracket Assembly

STEP 2

Locate the Passenger Side Front Mounting position on vehicle, there are (2) holes on the pinch weld and one threaded hole on the bottom floor, (Fig 2).

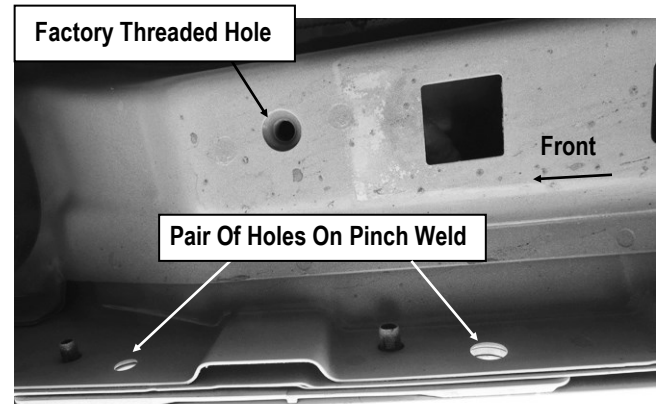

(Fig 2) Passenger Side Front Mounting Location

STEP 3

Attach the Assembled Passenger Front Mounting Bracket on the mounting position (Fig 3). Specifically mount Passenger Front Mounting Bracket (PFM) on the bottom threaded hole with (1) M8X1.25-35mm Hex Bolt, (1) M8 Large Flat Washer and (1) M8 Lock Washer. Install Passenger Front Support Bracket (PFS) on the pinch weld with (2) M6X1-25mm Hex Bolt, (4) M6 Large Flat Washers, and (2) M6X1 Nylon Lock Nuts. Do not fully tighten hardware at this time.

iArmor®

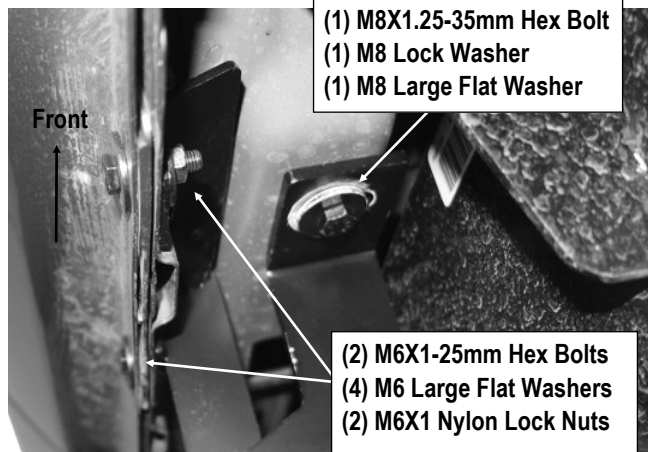

(Fig 3) Passenger Front Mounting Bracket Installed

STEP 4

Move to the rear of the vehicle. Assemble the Passenger Rear Mounting Bracket (PRM) and Passenger Rear Support Brackets (PRS) with (1) M8X1.25-35mm Hex Bolt, (2) M8 Flat Washers and (1) M8X1.25 Nylon Lock Nut, (Fig 4). Do not fully tighten hardware at this time.

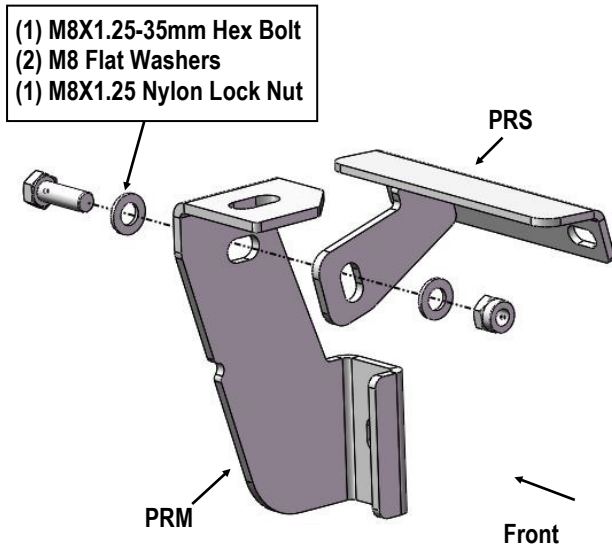

(Fig 4) Passenger Rear Mounting Bracket Assembly

STEP 5

Locate the Passenger Side Rear Mounting position on vehicle (Fig 5). Attach the Assembled Passenger Rear Mounting Bracket on the mounting position. Mount Passenger Rear Mounting Bracket (PRM) on the bottom threaded hole with (1) M8X1.25-35mm Hex Bolt, (1) M8 Large Flat Washer and (1) M8 Lock Washer. Install Passenger Rear Support Brackets (PRS) on the pinch weld with (2) M6X1-25mm Hex Bolt, (4) M6 Large Flat Washers, and (2) M6X1 Nylon Lock Nuts, (Fig 6). Do not fully tighten hardware at this time.

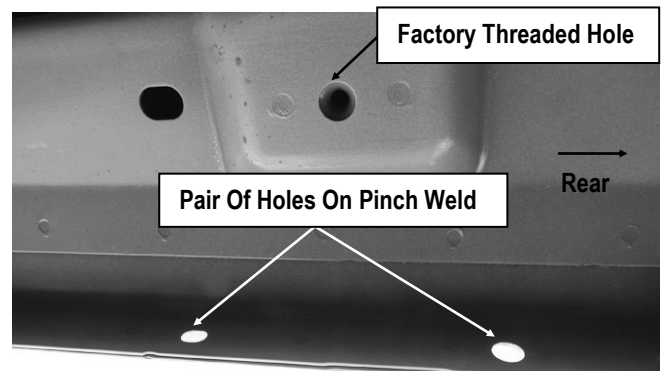

(Fig 5) Passenger Side Rear Mounting Location

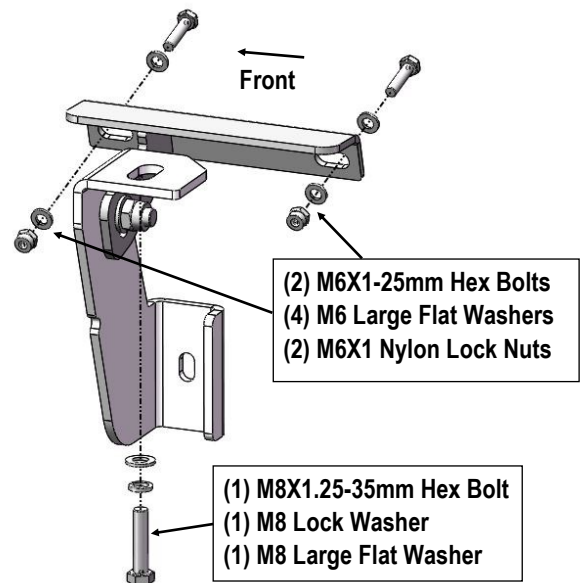

(Fig 6) Assembled Passenger Rear Mounting Bracket Installation

iArmor®

STEP 6

Once all (2) passenger side mounting brackets are installed, select and attach the Passenger Side Step Bar onto the Mounting Brackets with (2) U Brackets, (4) Spacers, (2) M8X1.25-55mm Carriage Bolts, (2) M8 Large Flat Washers, (2) M8 Lock Washers and (2) M8X1.25 Hex Nuts, (Fig 7). Do not fully tighten hardware at this time.

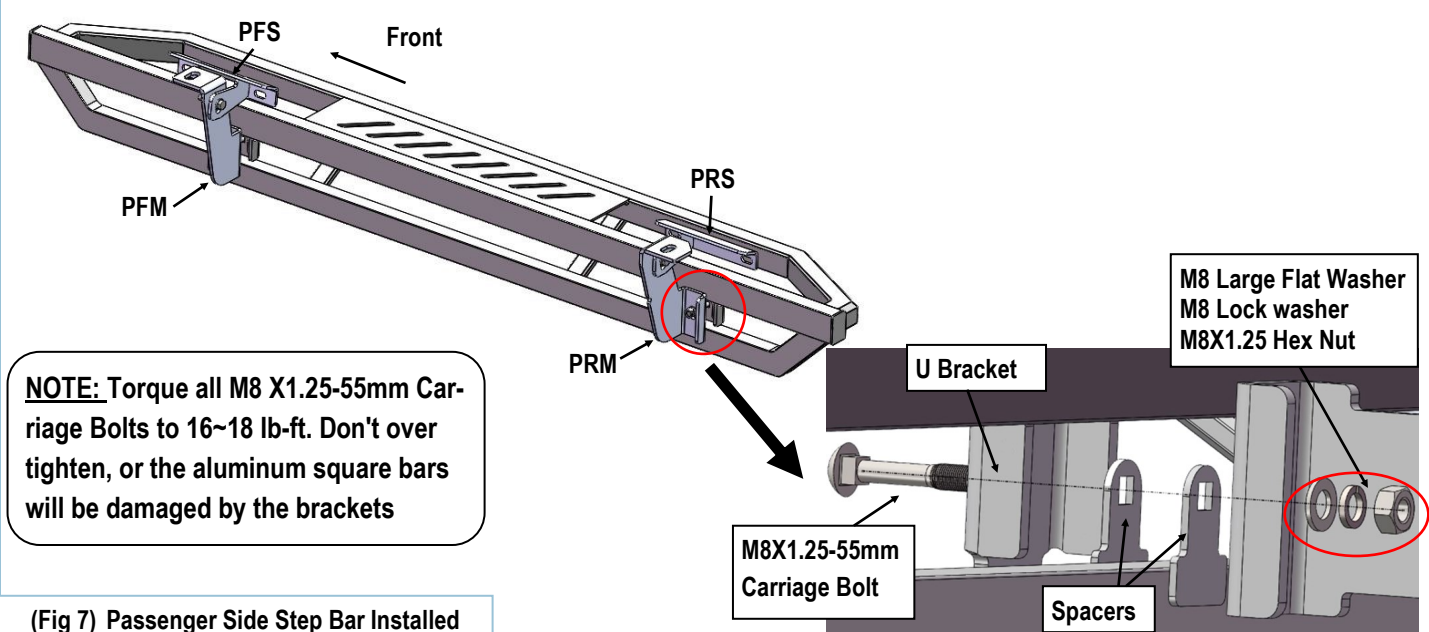

(Fig 7) Passenger Side Step Bar Installed

STEP 7

Properly level and adjust the Step Bar and fully tighten all hardware.

STEP 8

Move to the other side of the vehicle. Repeat **Steps 1-7** to install driver side step bar.

Installation completed.

Attention

Do periodic inspections to the installation to make sure that all hardware is secure and tight.

In order to protect your bars/boards, please use only mild soap/non-abrasive products for cleaning.