

iArmor[®]

iArmor[®] by APS

PART#: IA-S115

BEFORE INSTALLATION

REMOVE CONTENTS FROM BOX. VERIFY ALL PARTS ARE PRESENT. READ INSTRUCTIONS CAREFULLY BEFORE STARTING INSTALLATION. ASSISTANCE IS RECOMMENDED. THANK YOU FOR CHOOSING OUR PRODUCT!

***ROCKER PANEL MOUNT**

***NO DRILLING / TRIMMING REQUIRED**

Torque Value

| Fastener Size | Tightening Torque (ft-lbs) | Required |
|---------------|----------------------------|----------|
| 6mm | 6-7 | √ |
| 8mm | 16-18 | √ |
| 10mm | 31-32 | X |
| 12mm | 56-58 | X |
| 14mm | 92-94 | X |

PART LIST

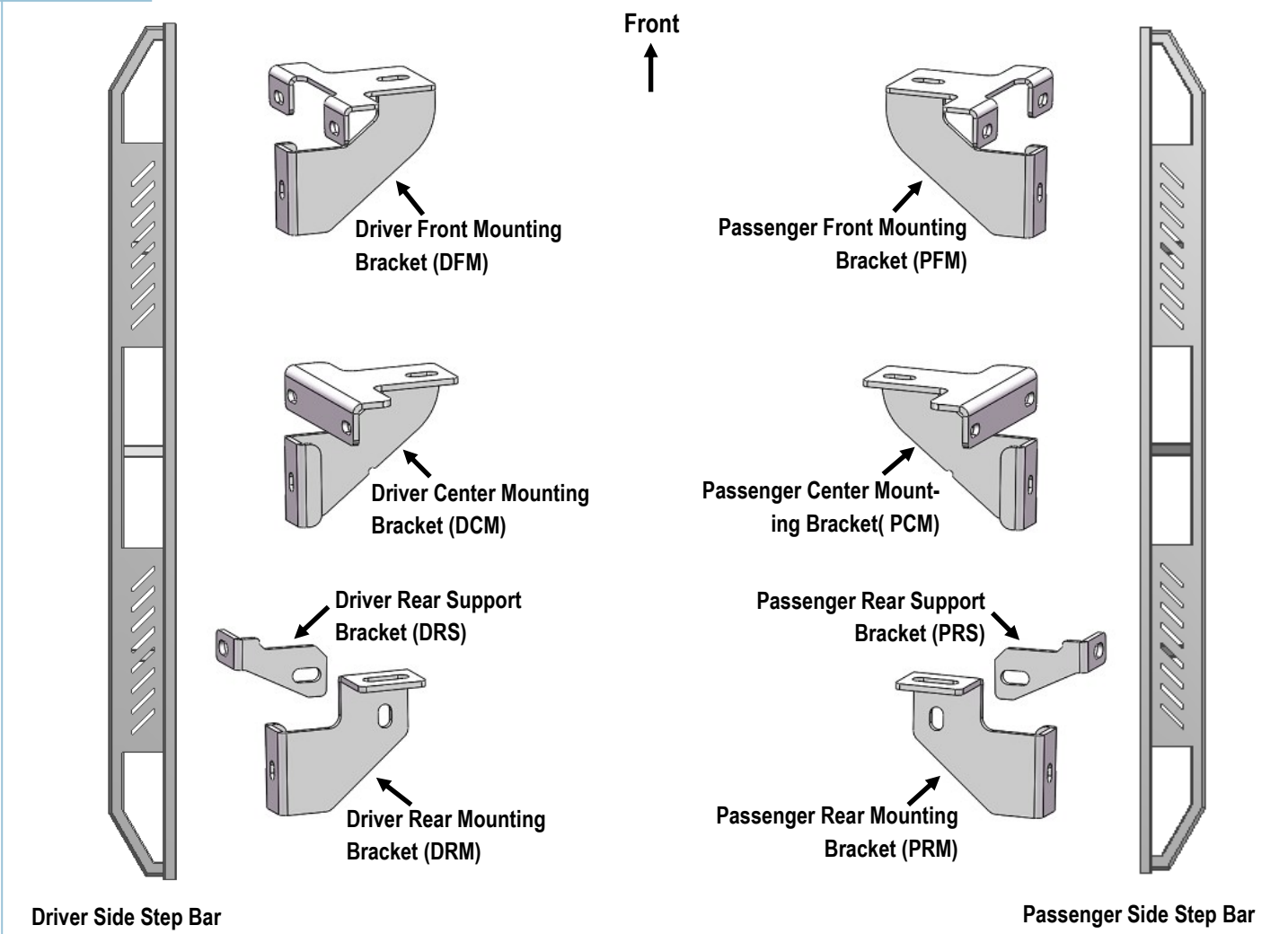

Customer Support: info@iarmorauto.com

iArmor®

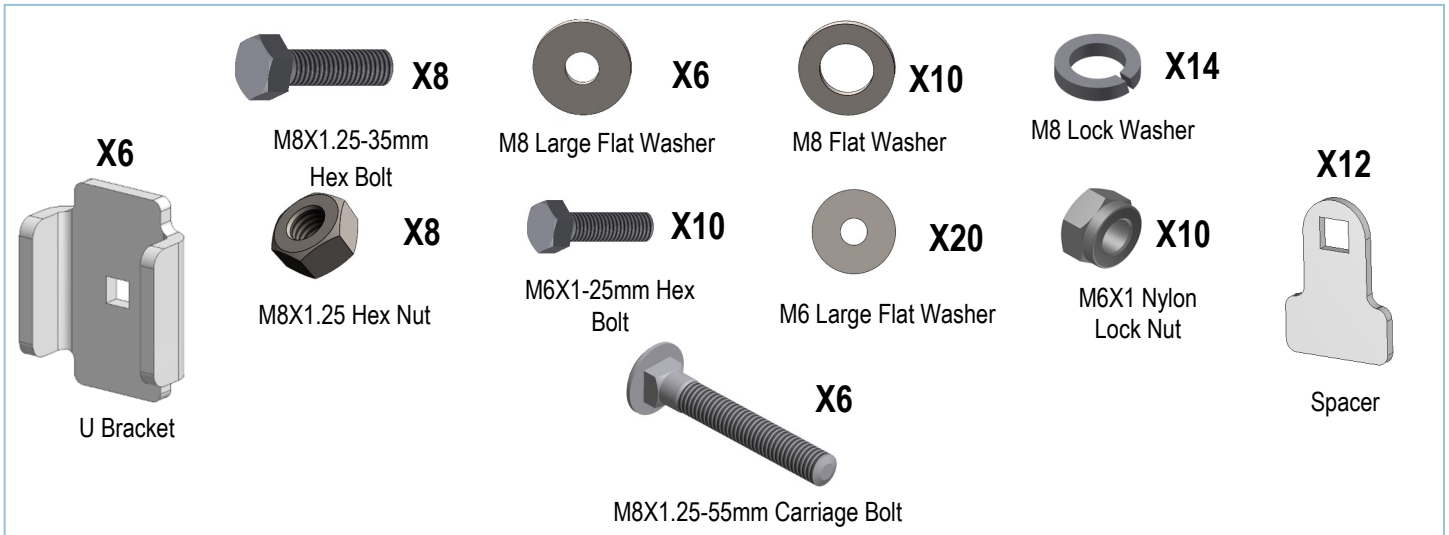

The instruction here is for your reference only. We strongly recommend the professional installer for best result. We are not responsible for any damage caused by the installation.

STEP 1

Start installation from the passenger side front of the vehicle. Locate the factory threaded mounting hole in the bottom of the floor, **(Fig 1)**.

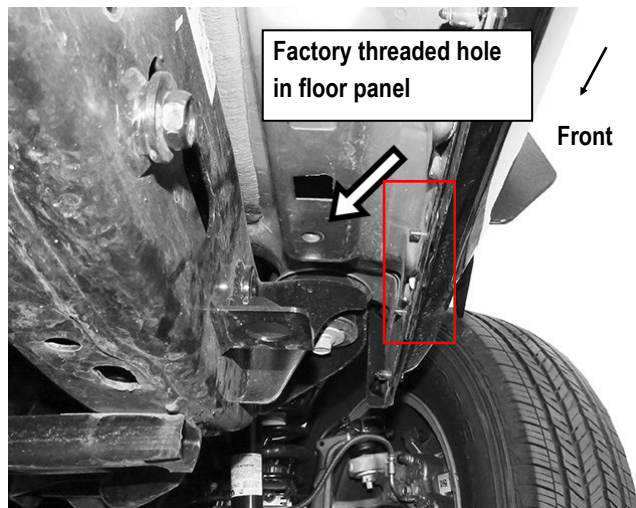

(Fig 1) Passenger Side Front Mounting Location

STEP 2

Select the Passenger Front Mounting Bracket (**PFM**), attach the top of the Passenger Front Mounting Bracket to the threaded hole in the bottom of the floor panel with the included (1) M8X1.25-35mm Hex Bolt, (1) M8 Lock Washer and (1) M8 Flat Washer, **(Fig 2)**.

Attach the lower (2) holes to the inner side of pinch weld with (2) M6X1-25mm Hex Bolts, (4) M6 Large Flat Washers and (2) M6X1 Nylon Lock Nuts, **(Fig 2)**. Do not fully tighten hardware at this time.

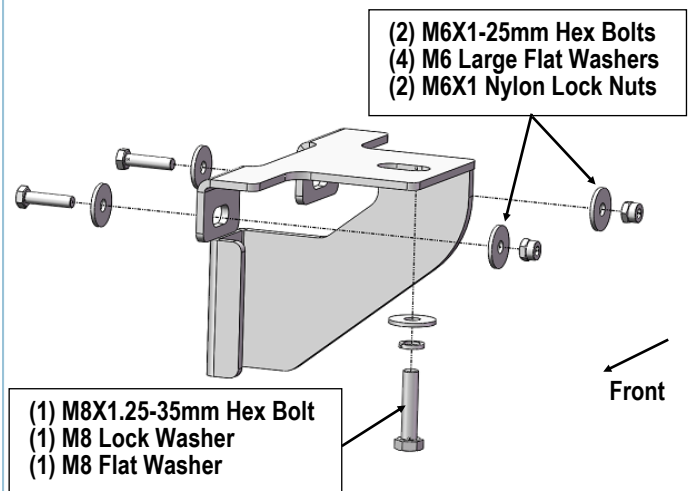

(Fig 2) Passenger Front Mounting Bracket Installed

iArmor®

STEP 3

Move to the passenger side center mounting location, (Fig 3). Select the Passenger Center Mounting Bracket (PCM). Repeat **Step 2** to install the passenger center mounting bracket to the center mounting location (Fig 4). Do not fully tighten hardware at this time.

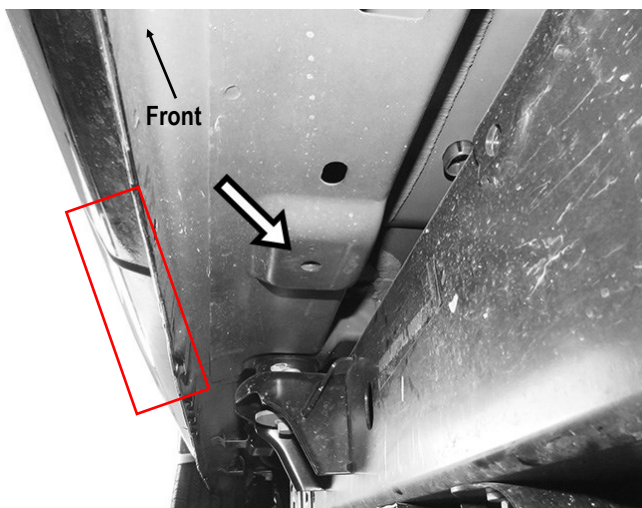

(Fig 3) Passenger Side Center Mounting Location

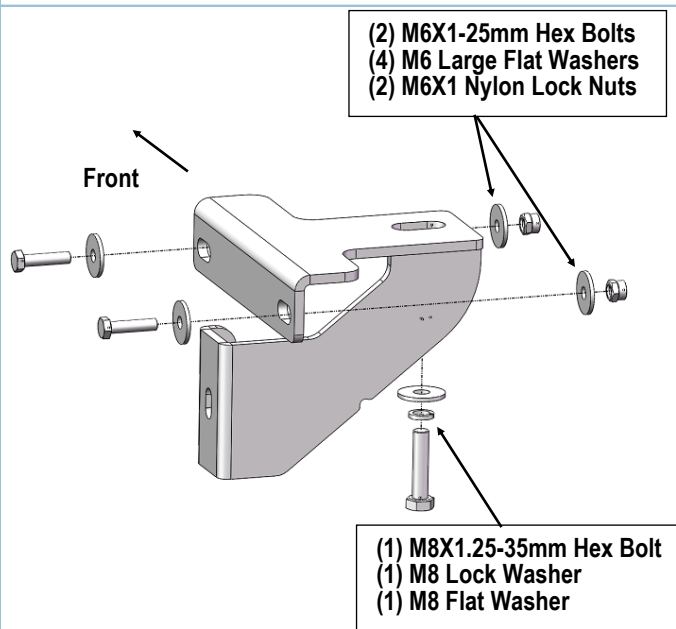

(Fig 4) Passenger Center Mounting Bracket Installed

STEP 4

Continue to the rear mounting location (Fig 5). Assemble Passenger Rear Mounting Bracket (PRM) and Passenger Rear Support Bracket (PRS) together with (1) M8X1.25-35mm Hex Bolt, (2) M8 Flat Washers and (1) M8X1.25 Nylon Lock Nut (Fig 6).

Attach the top of the Assembled Passenger Rear Mounting Bracket to the threaded hole in the bottom of the floor panel with (1) M8X1.25-35mm Hex Bolt, (1) M8 Lock Washer and (1) M8 Flat Washer, (Fig 7). Attach the Passenger Rear Support Bracket (PRS) on the inner side of pinch weld with (1) M6X1-25mm Hex Bolt, (2) M6 Large Flat Washers and (1) M6X1 Nylon Lock Nut, (Fig 7). Do not fully tighten hardware at this time.

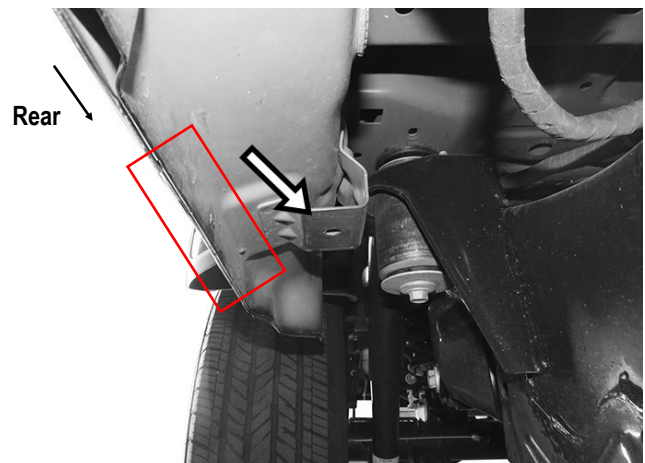

(Fig 5) Passenger Side Rear Mounting Location

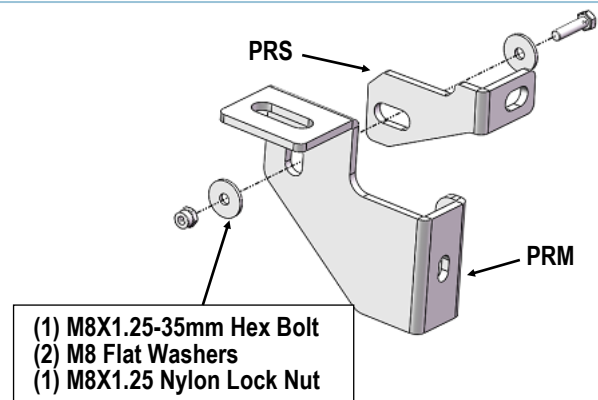

(Fig 6) Passenger Rear Mounting Bracket Assembly

iArmor®

- (1) M6X1-25mm Hex Bolts
- (2) M6 Flat Washers
- (1) M6X1 Nylon Lock Nuts

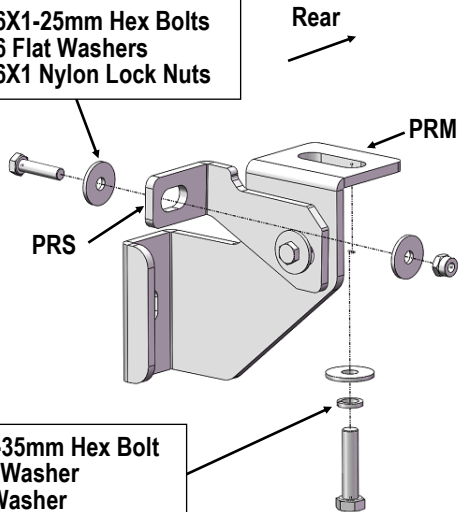

(Fig 7) Passenger Rear Bracket Installed

Attention

Do periodic inspections to the installation to make sure that all hardware is secure and tight.

In order to protect your bars/boards, please use only mild soap/non-abrasive products for cleaning.

STEP 5

Once all (3) passenger side mounting brackets are installed, select and attach the Passenger Side Step Bar onto the Mounting Brackets with (3) U Brackets, (6) Spacers, (3) M8X1.25-55mm Carriage Bolts, (3) M8 Large Flat Washers, (3) M8 Lock Washers and (3) M8X1.25 Hex Nuts, (Fig 8). Do not fully tighten hardware at this time

STEP 6

Properly level and adjust the Step Bar and fully tighten all hardware.

STEP 7

Move to the driver side of the vehicle. Repeat Steps 1-6 to install the driver side step bar. Installation completed.

NOTE: Torque all M8 X1.25-55mm Carriage Bolts to 16~18 lb-ft. Don't over tighten, or the aluminum square bars will be damaged by the brackets

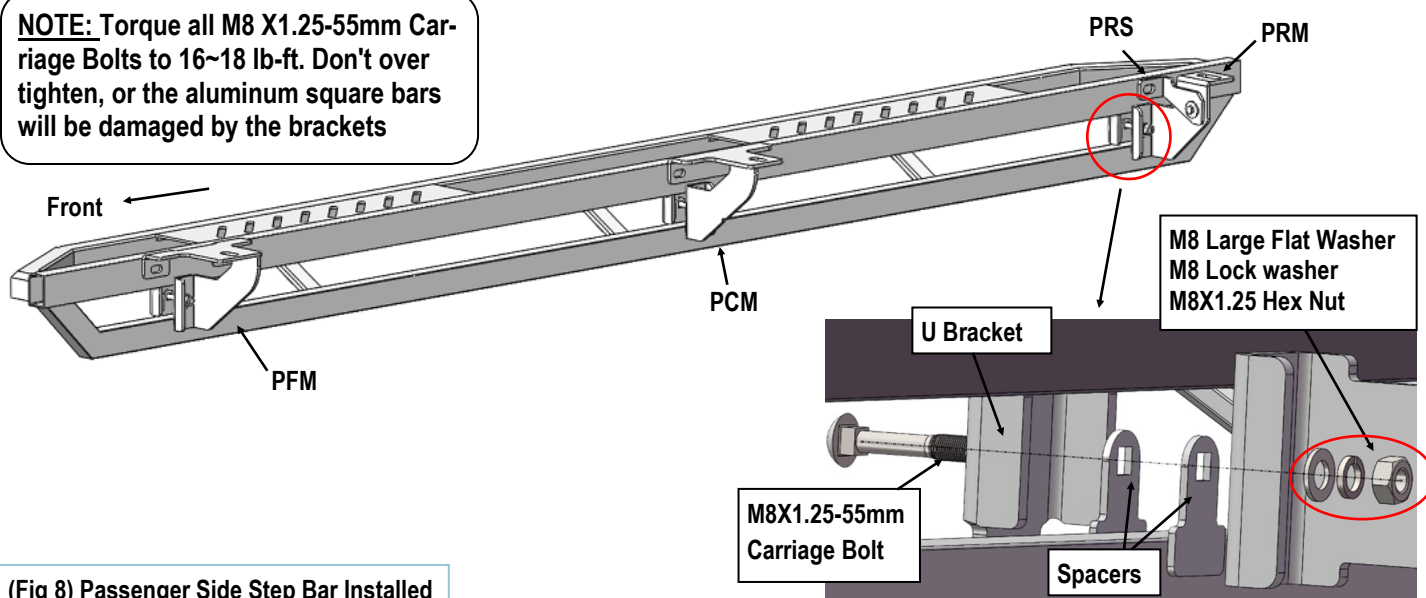

(Fig 8) Passenger Side Step Bar Installed

Customer Support: info@iarmorauto.com