

# iArmor<sup>®</sup>

## iArmor<sup>®</sup> by APS

PART#: IA-S111

### BEFORE INSTALLATION

REMOVE CONTENTS FROM BOX. VERIFY ALL PARTS ARE PRESENT. READ INSTRUCTIONS CAREFULLY BEFORE STARTING INSTALLATION. ASSISTANCE IS RECOMMENDED. THANK YOU FOR CHOOSING OUR PRODUCT!

**\*ROCKER PANEL MOUNT**

**\*NO DRILLING / TRIMMING REQUIRED**

### Torque Value

Fastener Size	Tightening Torque (ft-lbs)	Required
6mm	6-7	√
8mm	16-18	√
10mm	31-32	X
12mm	56-58	X
14mm	92-94	X

### PART LIST

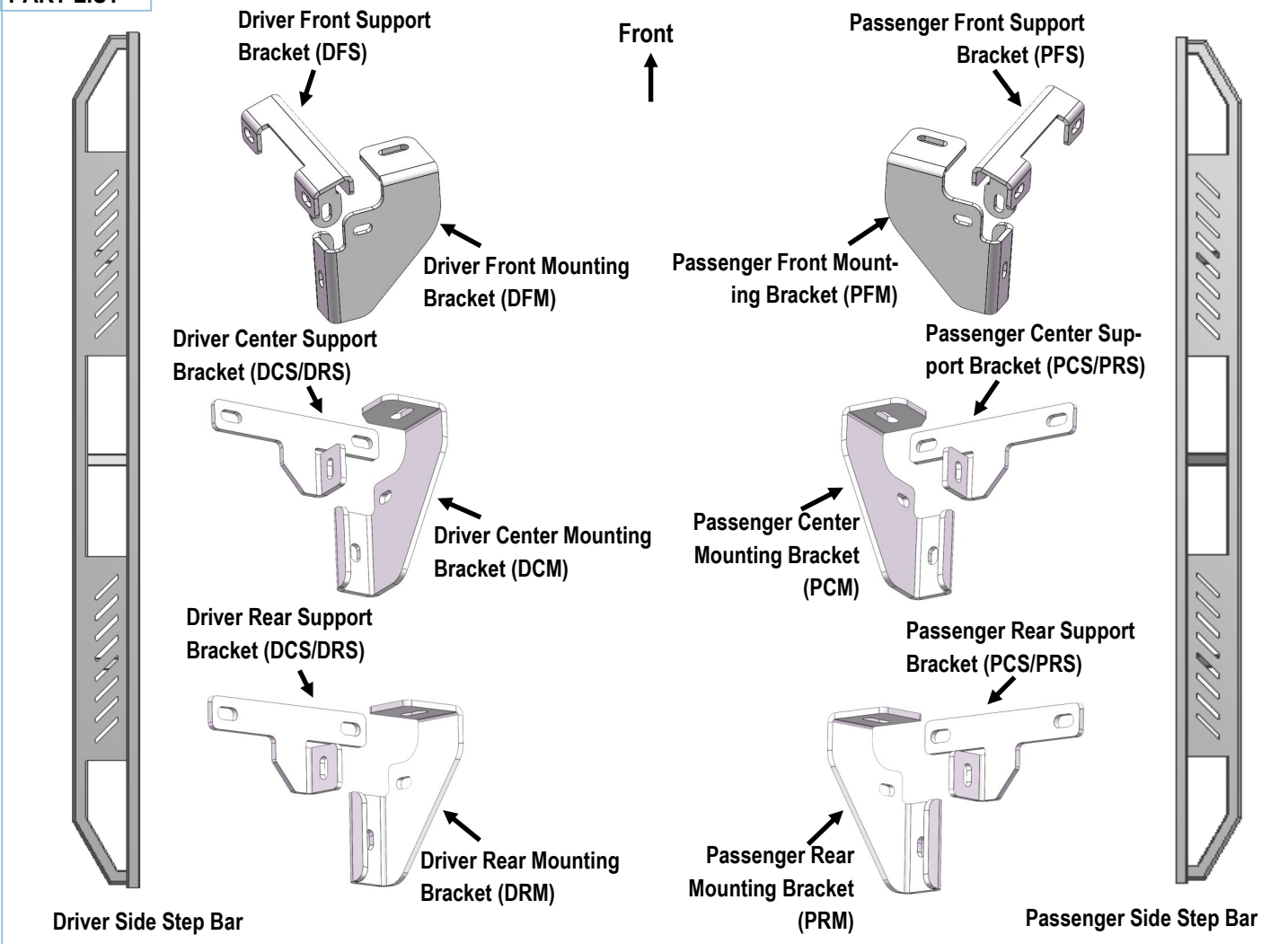

Customer Support: [info@iarmorauto.com](mailto:info@iarmorauto.com)

# iArmor®



The instruction here is for your reference only. We strongly recommend the professional installer for best result. We are not responsible for any damage caused by the installation.

## STEP 1

Start installation from the Passenger side of the vehicle. Locate the (3) pairs of factory mounting holes along the pinch weld (Fig 1).

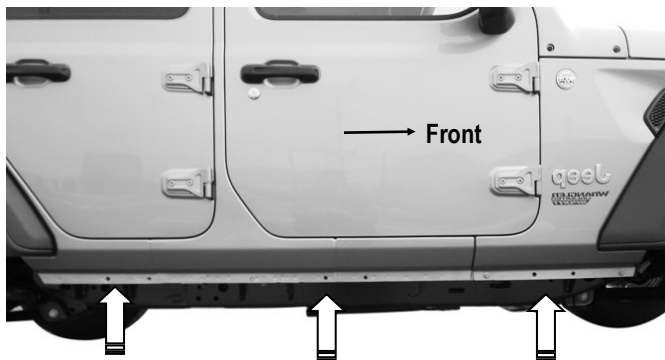

(Fig 1) Locate The (3) Factory Pair Of Holes Along The Pinch Weld

## STEP 2

Start installation from the passenger side front of the vehicle (Fig 2). Assemble Passenger Front Mounting Bracket (PFM) and Passenger Front Support Bracket (PFS) with (1) M8X1.25-25mm Hex Bolt, (2) M8 Large Flat Washers, (1) M8 Lock Washer and (1) M8X1.25 Hex Nut, (Fig 3).

And then install the Passenger Front Brackets to the rocker panel as shown, (Fig 4). Don't fully tighten the hardware at this time.

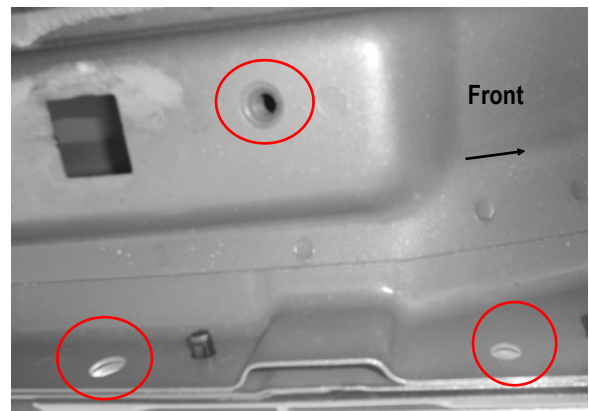

(Fig 2) Passenger Side Front Mounting Location

# iArmor®

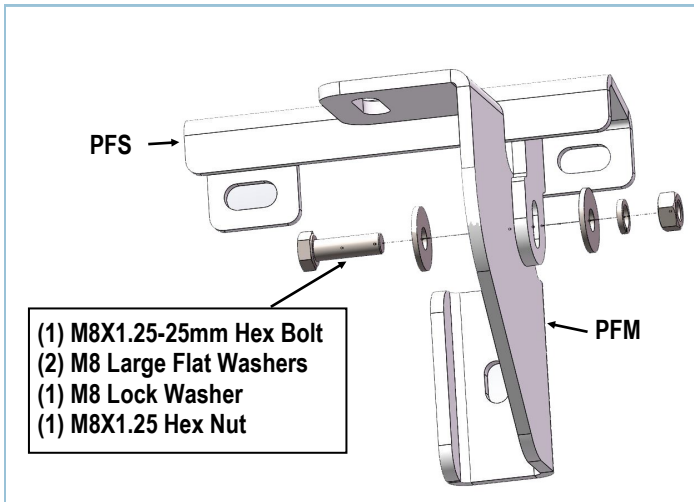

- (1) M8X1.25-25mm Hex Bolt
- (2) M8 Large Flat Washers
- (1) M8 Lock Washer
- (1) M8X1.25 Hex Nut

(Fig 3) Passenger Front Mounting Bracket (PFM) and Passenger Front Support Bracket (PFS) Assembly

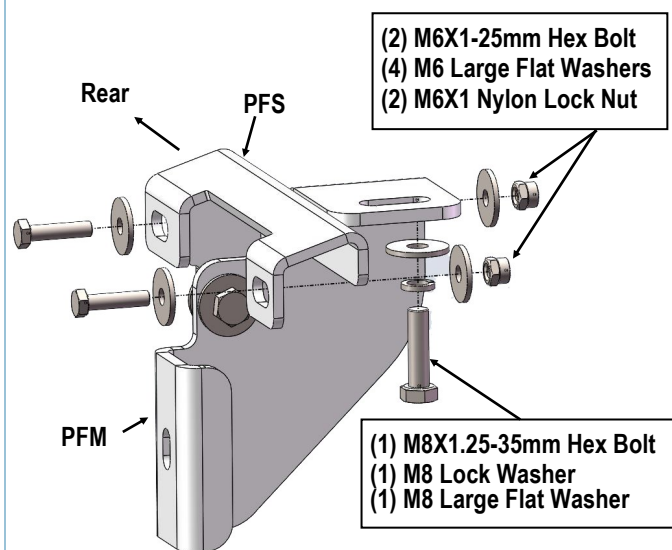

(Fig 4) Passenger Side Front Brackets Installation Pictured

## STEP 3

Move to Passenger Side Center & Rear Mounting Locations, (Figs 5 & 6). Repeat step 2 to install Passenger Center and Rear Brackets, (Figs 7-8). Don't fully tighten the hardware at this time.

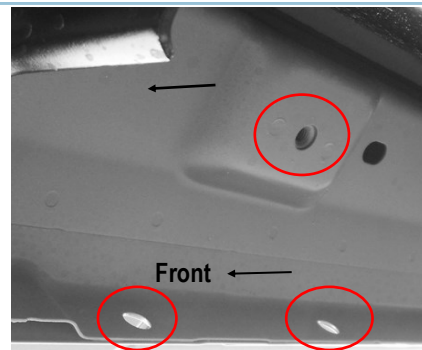

(Fig 5) Passenger Side Center Mounting Location

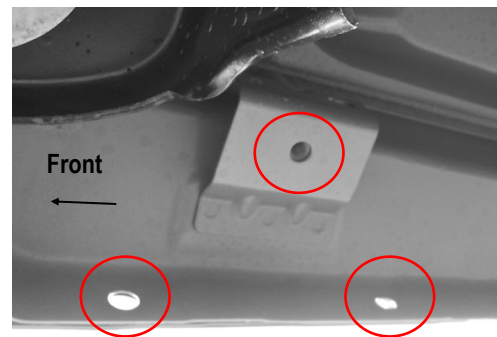

(Fig 6) Passenger Side Rear Mounting Location

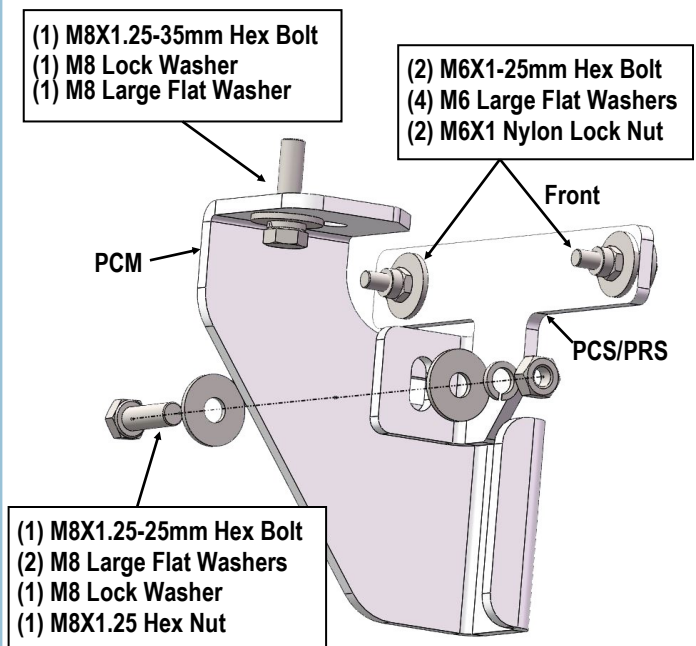

(Fig 7) Passenger Side Center Brackets Installation Pictured

# iArmor®

## STEP 4

Once all (3) passenger side mounting brackets are installed, select and attach the Passenger Side Step Bar onto the Mounting Brackets with (3) U Brackets, (6) Spacers, (3) M8X1.25-55mm Carriage Bolts, (3) M8 Large Flat Washers, (3) M8 Lock Washers and (3) M8X1.25 Hex Nuts, (Fig 9). Do not fully tighten hardware at this time. Properly level and adjust the Step Bar and fully tighten all hardware.

## STEP 5

Move to the driver side of the vehicle. Repeat **Steps 1-4** for the Driver Side Bar installation.

Installation completed.

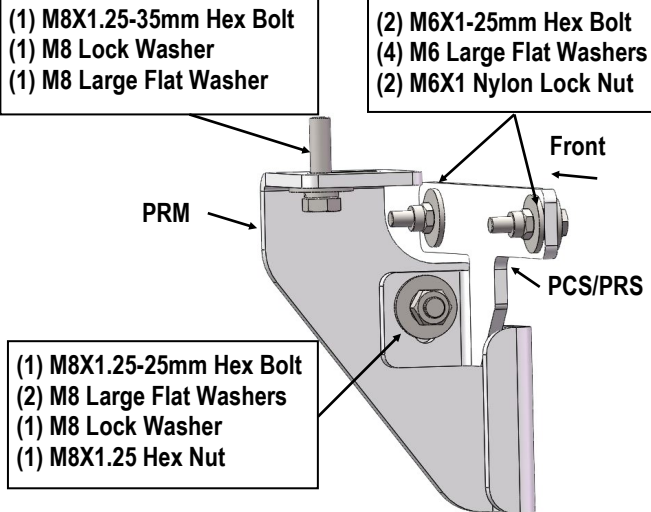

(Fig 8) Passenger Side Rear Brackets Installation Pictured

### Attention

Do periodic inspections to the installation to make sure that all hardware is secure and tight. In order to protect your bars/boards, please use only mild soap/non-abrasive products for cleaning.

**NOTE:** Torque all M8 X1.25-55mm Carriage Bolts to 16~18 lb-ft. Don't over tighten, or the aluminum square bars will be damaged by the brackets

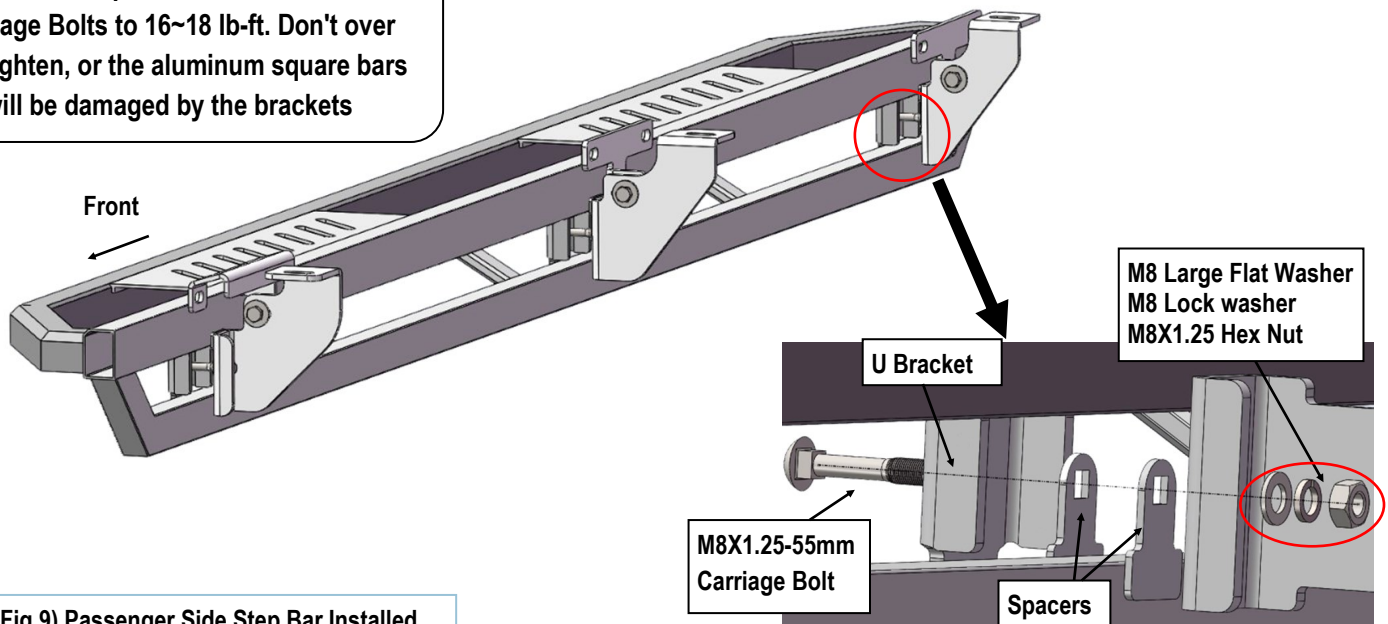

(Fig 9) Passenger Side Step Bar Installed