

iArmor®

IARMOR EDGE™

PART#: IA-N093

BEFORE INSTALLATION

REMOVE CONTENTS FROM BOX. VERIFY ALL PARTS ARE PRESENT. READ INSTRUCTIONS CAREFULLY BEFORE STARTING INSTALLATION. ASSISTANCE IS RECOMMENDED. THANK YOU FOR CHOOSING OUR PRODUCT!

*DRILLING NOT REQUIRED

*TRIMMING NOT REQUIRED

Torque Value

Fastener Size	Tightening Torque (ft-lbs)	Required
6mm	6-7	√
8mm	16-18	X
10mm	31-32	X
12mm	56-58	√
14mm	92-94	X

PART LIST

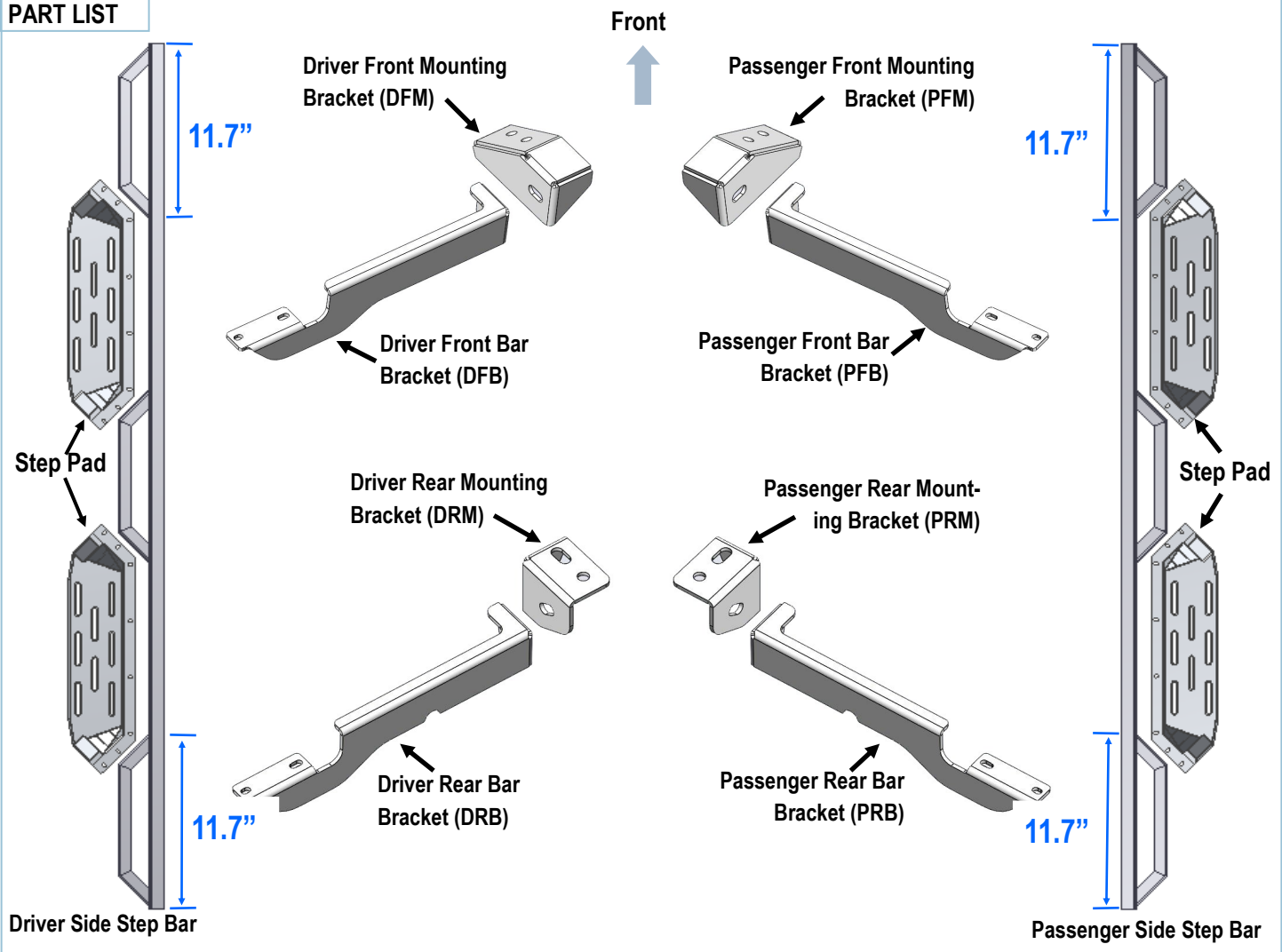

Customer Support: info@iarmorauto.com

iArmor[®]

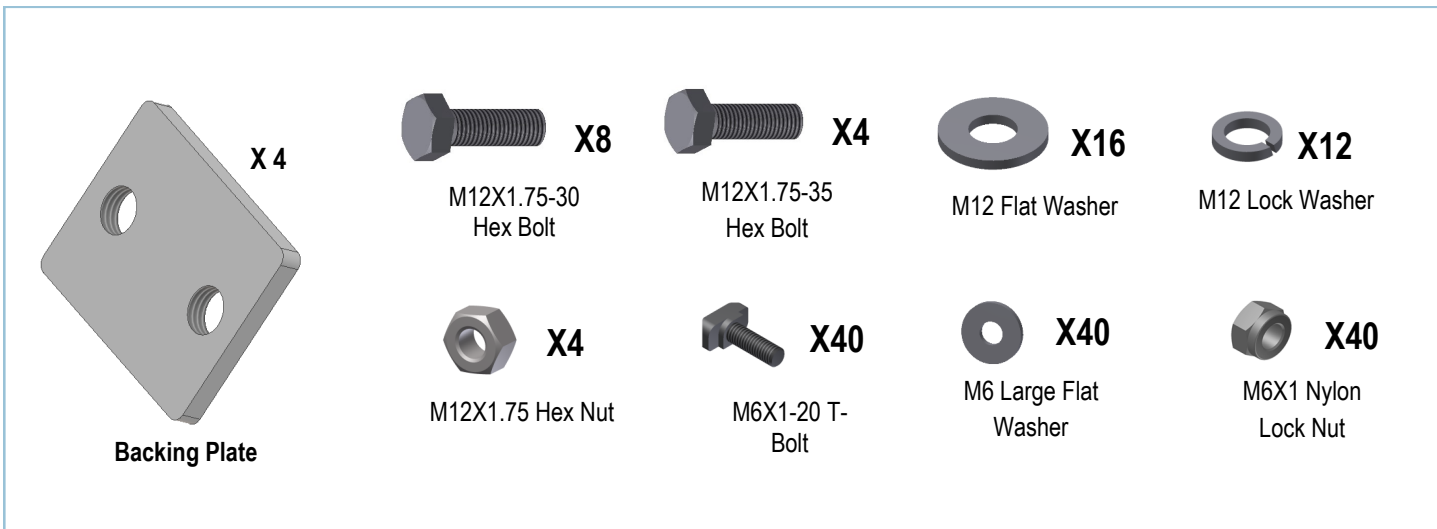

The instruction here is for your reference only. We strongly recommend the professional installer for best result. We are not responsible for any damage caused by the installation.

STEP 1

Install the Step Pads onto the step bars with (32) M6X1-20mm T-Bolts, (32) M6 Large Flat Washers and (32) M6X1 Nylon Lock Nuts.

IMPORTANT: Don't hit the step pad by any metal hammer within step pad installation, or the step pad will be damaged.

(8) M6X1-20 T-Bolts
(8) M6 Flat Washers
(8) M6X1 Nylon Lock Nuts

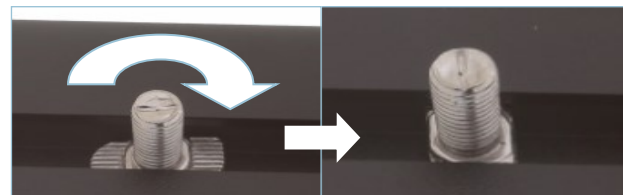

Note: Rotate 90° after inserting the T-Bolts into the Channel!!!

STEP 2

Start installation on the driver side front of the vehicle. Assemble the Driver Front Mounting Bracket (DFM) and Driver Front Bar Bracket (DFB), with (1) M12x1.75-35 Hex Bolt, (2) M12 Flat Washers, (1) M12 Lock Washer and (1) M12X1.75 Hex Nut (Fig 1). Do not fully tighten hardware at this time.

iArmor®

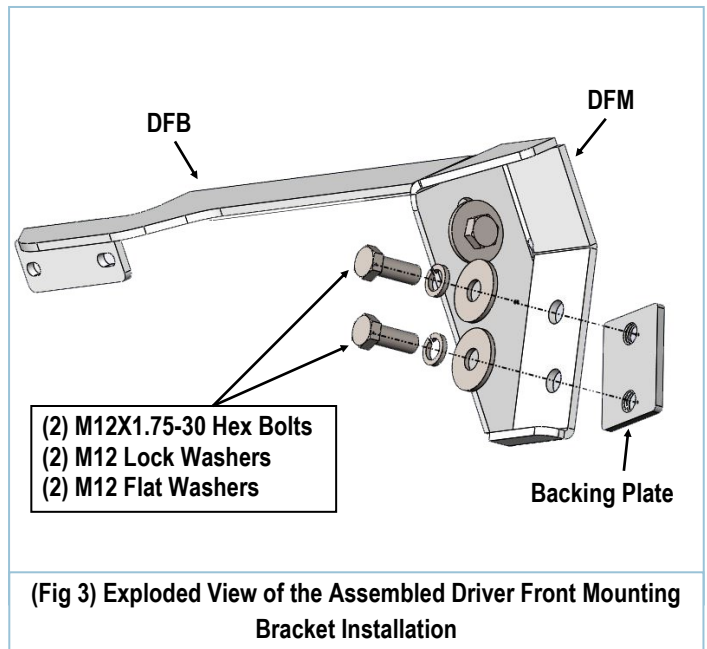
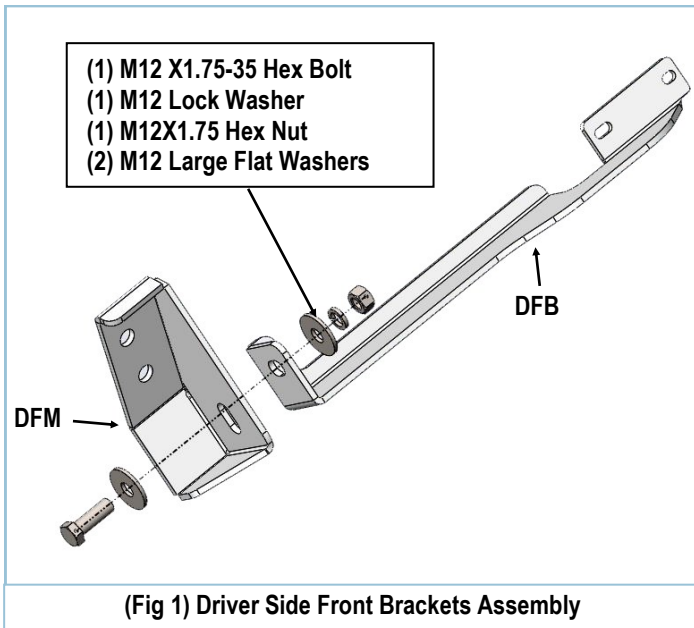

STEP 3

Select (1) Backing Plate and put it behind the body frame, line up the holes, attach (1) Driver Front Mounting Bracket (DFM) on the other side using (2) M12X1.75-30 Hex Bolts, (2) M12 Lock Washers and (2) M12 Flat Washers. Do not fully tighten hardware at this time, (Fig 2 & 3).

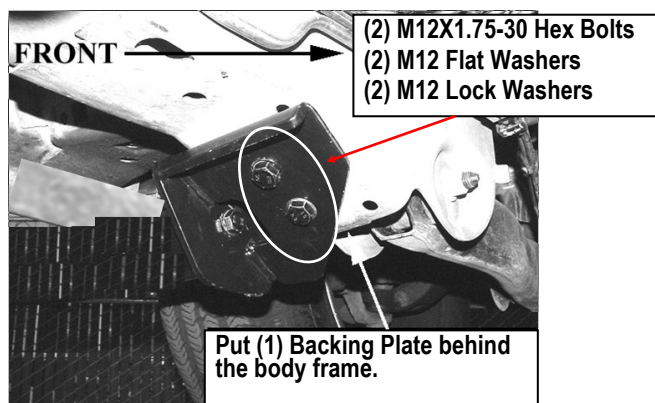

STEP 4

Move to the Driver Side Rear Mounting Location of the vehicle. Assemble the Driver Rear Mounting Bracket (DRM) and Driver Rear Bar Bracket (DRB) with (1) M12x1.75-35 Hex Bolt, (2) M12 Flat Washers, (1) M12 Lock Washer and (1) M12X1.75 Hex Nut, (Fig 4). Do not fully tighten hardware at this time.

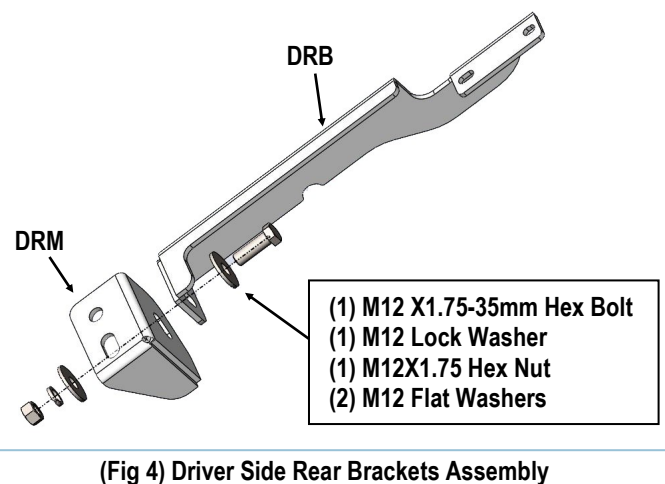

iArmor®

STEP 5

Repeat **Step 2** to install the Assembled Driver Rear Mounting Bracket. Do not fully tighten hardware at this time, (**Fig 5-6**).

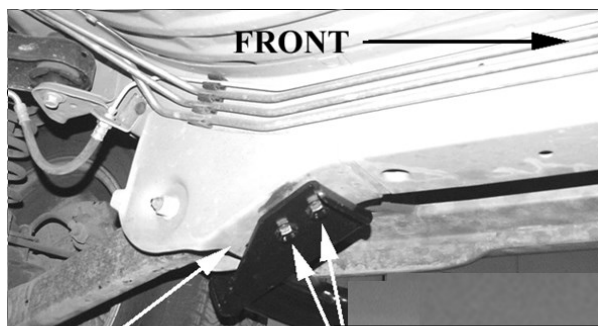

Place (1) Backing Plate behind the frame to attach the mounting bracket.

(2) M12 X1.75-30 Hex Bolts
(2) M12 Lock Washers
(2) M12 Flat Washers

(Fig 5) The Assembled Driver Rear Mounting Bracket Installed

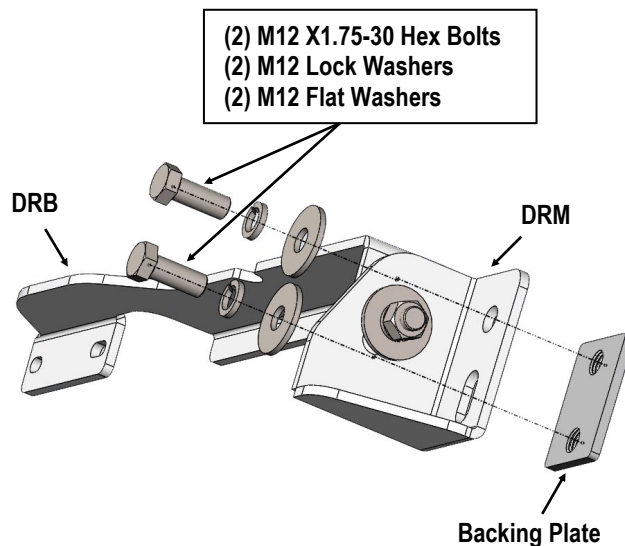

(Fig 6) Exploded View of the Assembled Driver Rear Mounting Bracket Installation

STEP 6

Once all (2) driver side mounting brackets are installed, attach the Assembled Driver Side Step Bar onto the brackets with (4) M6X1-20 T-Bolts, (4) M6 Large Flat Washers and (4) M6X1 Nylon Lock Nuts, (**Fig 7**). Do not tighten hardware.

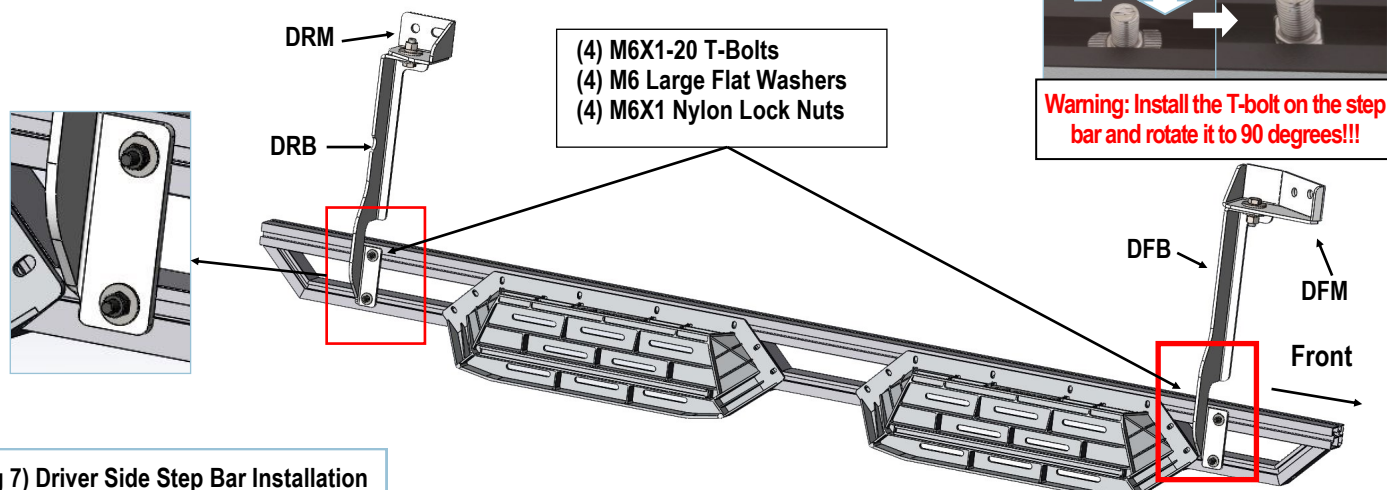

(Fig 7) Driver Side Step Bar Installation

iArmor[®]

STEP 7

Properly level and adjust the Step Bar and fully tighten all hardware.

STEP 8

Move to the passenger side of the vehicle. Repeat **Steps 2-7** to install passenger side step bar.

Attention

Do periodic inspections to the installation to make sure that all hardware is secure and tight.

In order to protect your bars/boards, please use only mild soap/non-abrasive products for cleaning.