

IARMOR EDGE™

PART#: IA-N277

BEFORE INSTALLATION

REMOVE CONTENTS FROM BOX. VERIFY ALL PARTS ARE PRESENT. READ INSTRUCTIONS CAREFULLY BEFORE STARTING INSTALLATION. ASSISTANCE IS RECOMMENDED. THANK YOU FOR CHOOSING OUR PRODUCT!

*DRILLING NOT REQUIRED

*TRIMMING NOT REQUIRED

Fastener Size	Tightening Torque (ft-lbs)	Required
6mm	6-7	√
8mm	16-18	√
10mm	31-32	√
12mm	56-58	X
14mm	92-94	X

Item	QTY	Description	Item	QTY	Description
1#	2	Driver Front / Passenger Rear Mounting Brackets	9#	8	M8X1.25-20 Inner Hex Bolts
2#	2	Passenger Front / Driver Rear Mounting Brackets	10#	8	M8X1.25 Hex Flange Nuts
3#	2	Driver Front / Passenger Rear Bar Brackets	11#	8	M6X1-25 Hex Bolts
4#	2	Passenger Front / Driver Rear Bar Brackets	12#	56	M6 Large Flat Washers
5#	4	M10 Bolt Plates	13#	48	M6X1 Nylon Lock Nuts
6#	4	M10 Plastic Washers	14#	8	M6X1-20 Square Head Bolts
7#	4	M10 Flat Washers	15#	32	M6X1-20 T-Bolts
8#	4	M10X1.5 Hex Flange Nuts			

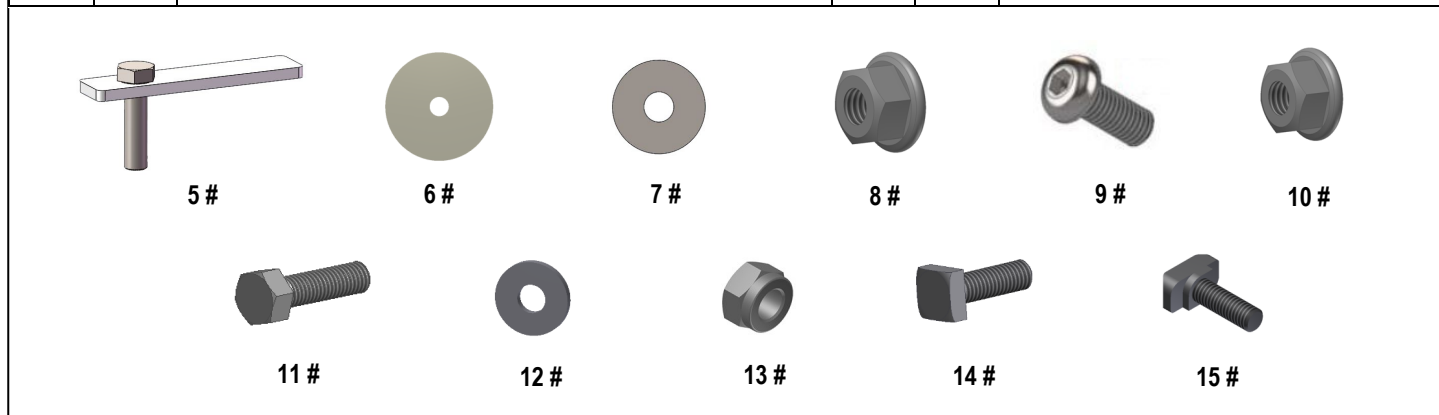

iArmor[®]

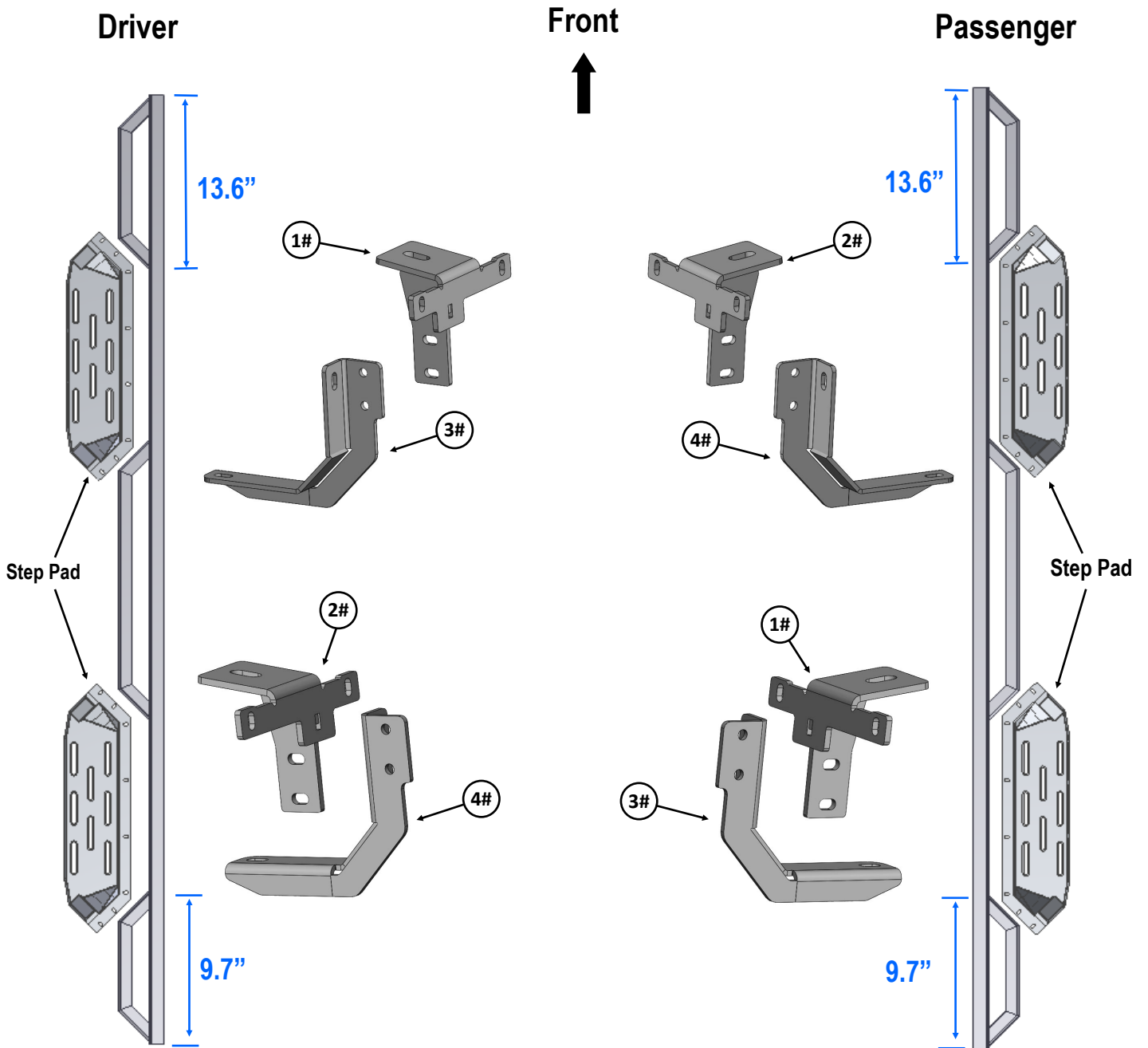

iArmor®

The instruction here is for your reference only. We strongly recommend the professional installer for best result. We are not responsible for any damage caused by the installation.

STEP 1

Install the Step Pads onto the step bars with (32) M6x1-20 T-Bolts, (32) M6 Flat Washers and (32) M6x1 Nylon Lock Nuts.

IMPORTANT: Don't hit the step pad by any metal hammer within step pad installation, or the step pad will be damaged.

(8) M6X1-20 T-Bolts
(8) M6 Flat Washers
(8) M6X1 Nylon Lock Nuts

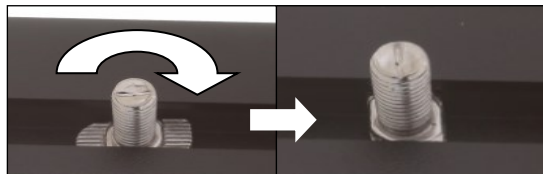

Note: Rotate 90° after inserting the T-Bolts into the Channel!!!

STEP 2

Start from the passenger side of the vehicle, locate the 2 pairs of (2) small holes in the pinch weld, (Fig 1). Remove the rubber plugs filling the oval hole in the bottom of the rocker panel directly in front of the (2) holes, (Fig 2).

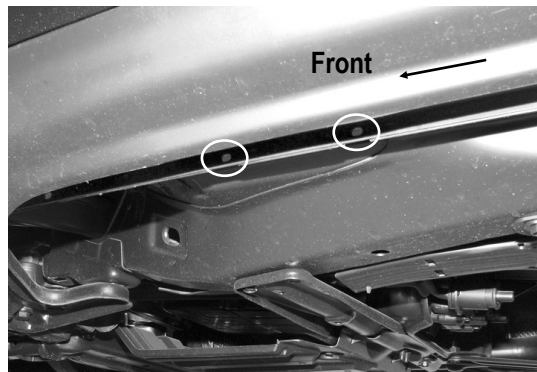

(Fig 1) Passenger Side Front Mounting Location on Pinch Weld



(Fig 2) Passenger Side Front Mounting Location on Rocker Panel

STEP 3

Select (1) M10 Bolt Plate and (1) Plastic Retainer. Insert the Bolt Plate into the oval hole and rotate 90-degrees to the slot, (Fig 3). (Insert Bolt Plate then rotate 90-degrees or until it stopped for proper installation.)

Thread the Plastic Retainer onto the Bolt Plate. Thread the Retainer down until it is tight against the sheet metal, (Fig 4).

NOTE: The Retainer is designed to hold the Bolt Plate in position during Bracket installation.



(Fig 3) Insert The M10 Bolt Plate

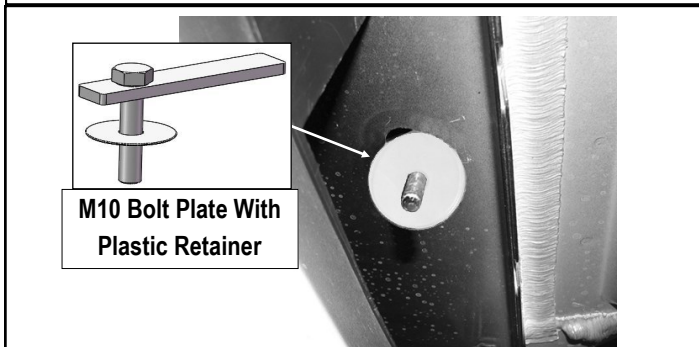

(Fig 4) Thread The Plastic Retainer On The Bolt Plate

STEP 4

Select (1) Passenger Front Bar Bracket, attach it to the Passenger Front Mounting Bracket with (2) M8X1.25-20 Inner Hex Bolts and (2) M8X1.25 Hex Flange Nuts, (Fig 5). Do not fully tighten hardware at this time.

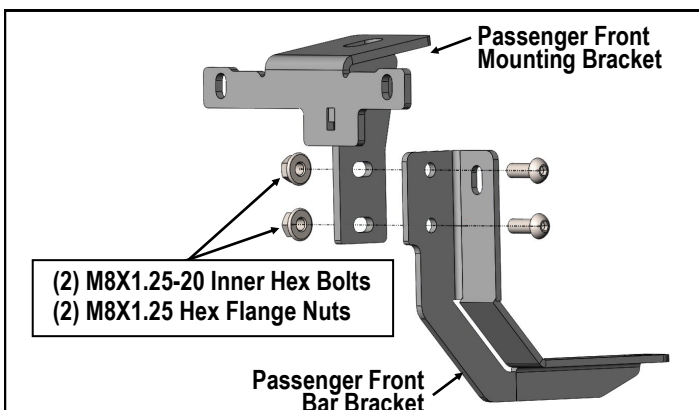

(Fig 5) Passenger Front Mounting Bracket Assembly

STEP 5

Attach the assembled Passenger Front Mounting Bracket to the M10 Bolt Plate with (1) M10 Flat Washer and (1) M10X1.5 Hex Flange Nut, (Fig 6). Next, bolt the Bracket to the pinch weld with (2) M6X1-25 Hex Bolts, (4) M6 Large Flat Washers and (2) M6X1 Nylon Lock Nuts, (Fig 6).

IMPORTANT: The passenger side of the vehicle may have a wiring harness attached behind the pinch weld, (Fig 7). Remove the hex nuts and drop the harness down before installing the Brackets. Install M6 Hex Bolts from the inside, then through the Bracket to clear the harness. Snug but do not fully tighten hardware at this time.

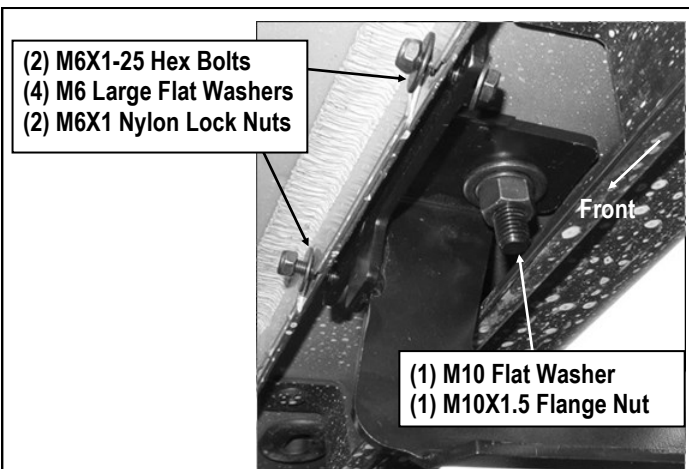

(Fig 6) Passenger Front Mounting Bracket Installation

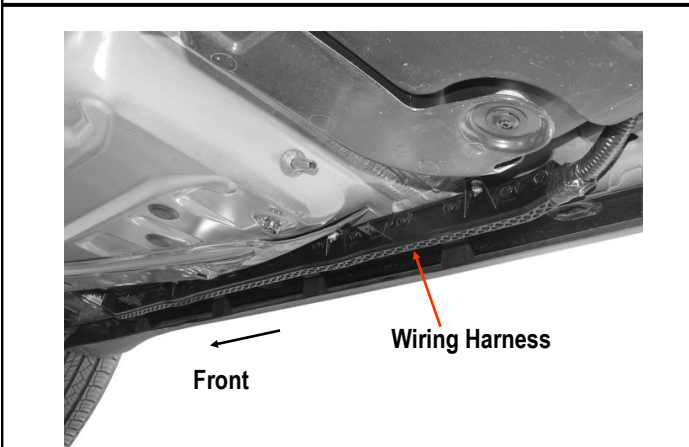

(Fig 7) Passenger Side Wiring Harness

iArmor®

STEP 6

Move to the passenger side rear of the vehicle, repeat **Steps 2-5** to assemble and install the Passenger Rear Mounting Bracket and Passenger Rear Bar Bracket. Do not fully tighten hardware at this time.

STEP 7

Once all (2) Brackets are installed. Attach the assembled Passenger Side Bar to the Mounting Brackets with (4) M6X1-20 Square Head Bolts, (4) M6 Large Flat Washers and (4) M6X1 Nylon Lock Nuts, (**Fig 8**). Do not fully tighten hardware at this time.

STEP 8

Properly level and adjust the Step Bar and fully tighten all hardware.

STEP 9

Move to the other side of the vehicle. Repeat **Steps 2-8** for other side Step Bar installation.

Attention

Do periodic inspections to the installation to make sure that all hardware is secure and tight.
In order to protect your bars/boards, please use only mild soap/non-abrasive products for cleaning.

(Fig 8) Passenger Side Step Bar Installation

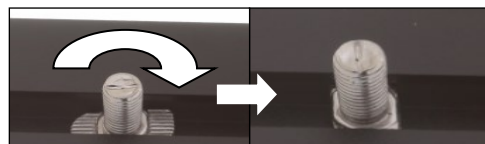
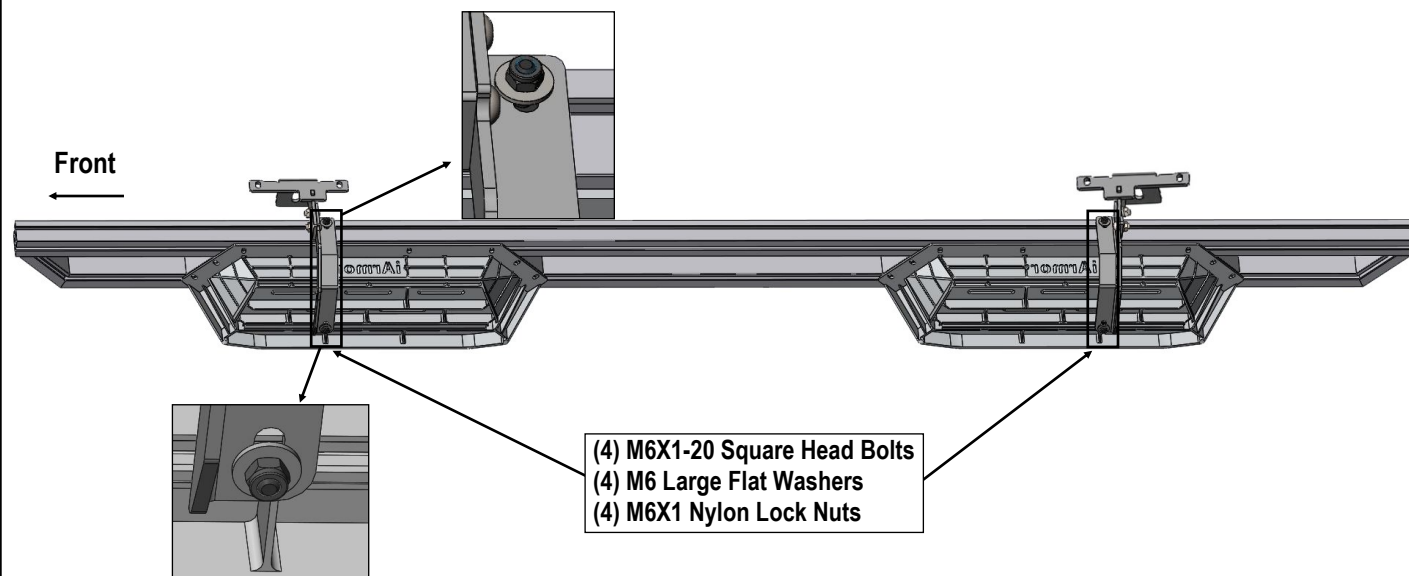

Warning: Install the T-bolt on the step bar and rotate it to 90 degrees!!!