

iArmor®

IARMOR EDGE™

PART#: IA-N219

BEFORE INSTALLATION

REMOVE CONTENTS FROM BOX. VERIFY ALL PARTS ARE PRESENT. READ INSTRUCTIONS CAREFULLY BEFORE STARTING INSTALLATION. ASSISTANCE IS RECOMMENDED. THANK YOU FOR CHOOSING OUR PRODUCT!

*DRILLING NOT REQUIRED

*TRIMMING NOT REQUIRED

Torque Value

| Fastener Size | Tightening Torque (ft-lbs) | Required |
|---------------|----------------------------|----------|
| 6mm | 6-7 | √ |
| 8mm | 16-18 | √ |
| 10mm | 31-32 | √ |
| 12mm | 56-58 | X |
| 14mm | 92-94 | X |

PART LIST

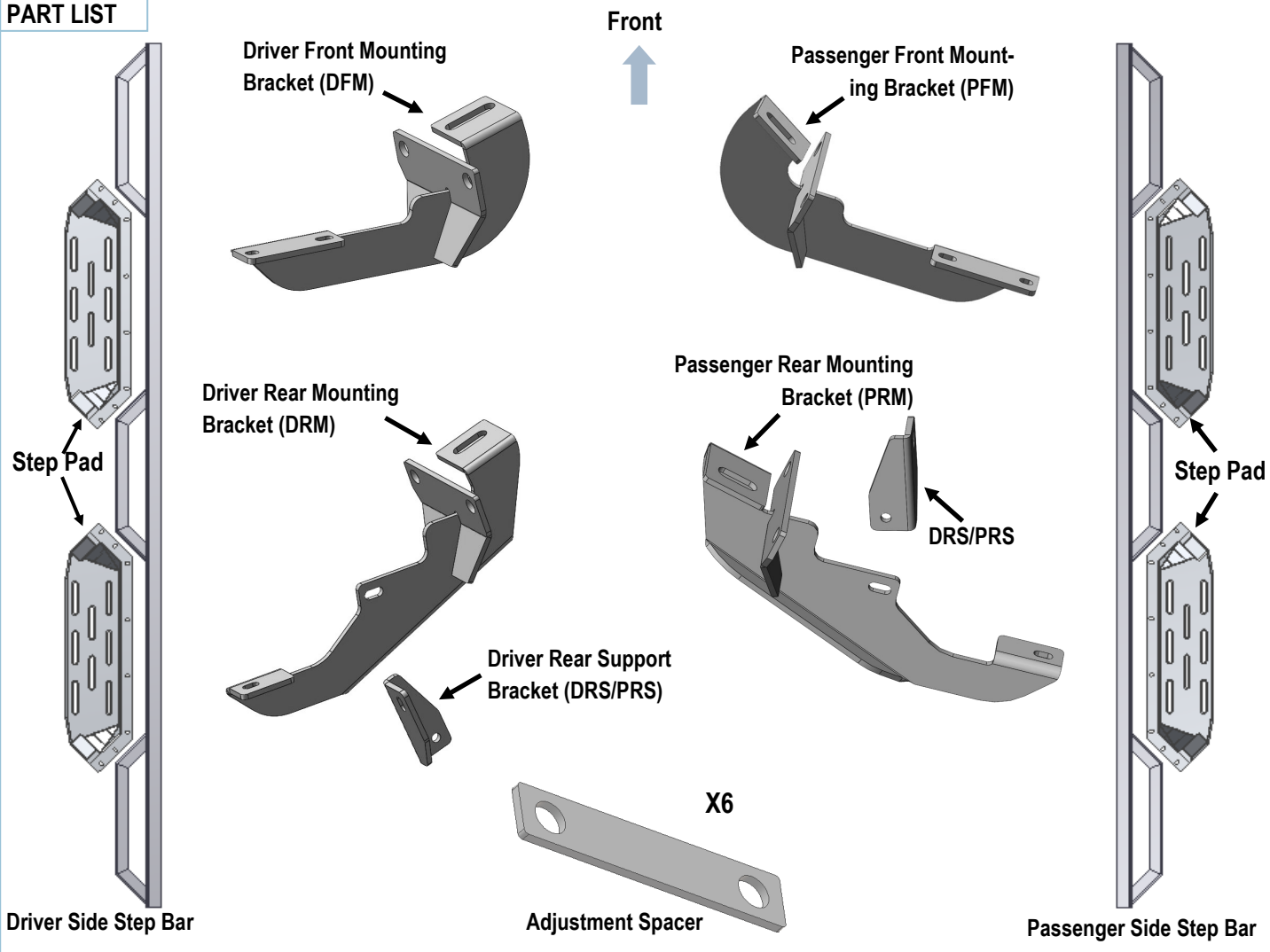

Customer Support: info@iarmorauto.com

iArmor®

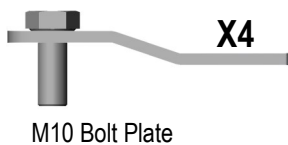

X4

M10 Bolt Plate



X4

M10 Large Flat Washer



X4

M10X1.5 Nylon Lock Nut

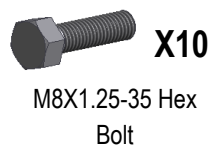

X10

M8X1.25-35 Hex Bolt



X20

M8 Flat Washer



X10

M8X1.25 Nylon Lock Nut



X36

M6X1-20 T-Bolt



X4

M6X1-20 Square Head Bolt



X40

M6 Large Flat Washer

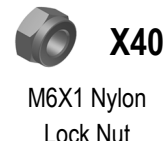

X40

M6X1 Nylon Lock Nut

The instruction here is for your reference only. We strongly recommend the professional installer for best result. We are not responsible for any damage caused by the installation.

STEP 1

Install the Step Pads onto the step bars with (32) M6X1-20 T-Bolts, (32) M6 Large Flat Washers and (32) M6X1 Nylon Lock Nuts.

IMPORTANT: Don't hit the step pad by any metal hammer within step pad installation, or the step pad will be damaged.

(8) M6X1-20 T-Bolts
(8) M6 Flat Washers
(8) M6X1 Nylon Lock Nuts

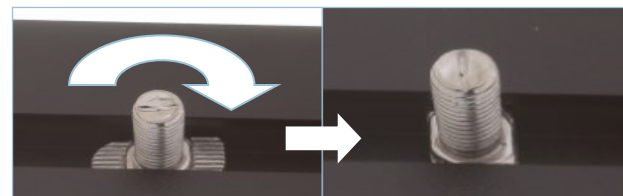

Note: Rotate 90° after inserting the T-Bolts into the Channel!!!

STEP 2

Start installation at passenger side front. Insert (1) M10 Bolt Plate into the rectangular hole and out the round hole in the bottom of the side panel, (Fig 1).

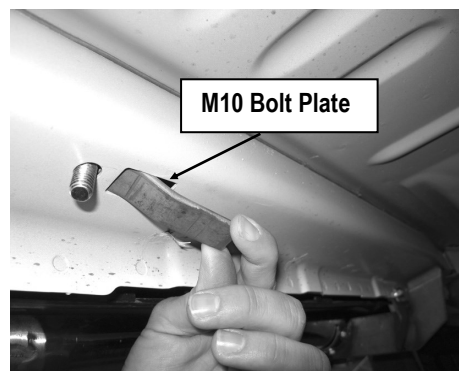

(Fig 1) Insert M10 Bolt Plate at the Passenger Front Location

iArmor®

STEP 3

Select (1) Passenger Front Mounting Bracket (**PFM**), attach it to the M10 Bolt Plate with included (1) M10 Flat Washer and (1) M10X1.5 Nylon Lock Nut, (**Fig 2**). **NOTE:** Make sure that the mounting tab on the Bracket is on the outside of the pinch weld. Line up the (2) holes in the Bracket with the factory holes in the pinch weld. Attach the Bracket to the pinch weld using the included (2) M8X1.25-35 Hex Bolts, (4) M8 Flat Washers and (2) M8X1.25 Nylon Lock Nuts, (**Fig 2**). Do not fully tighten at this time.

IMPORTANT: The front Brackets are different from the rear Brackets, Identify the Brackets by reading Part List carefully.

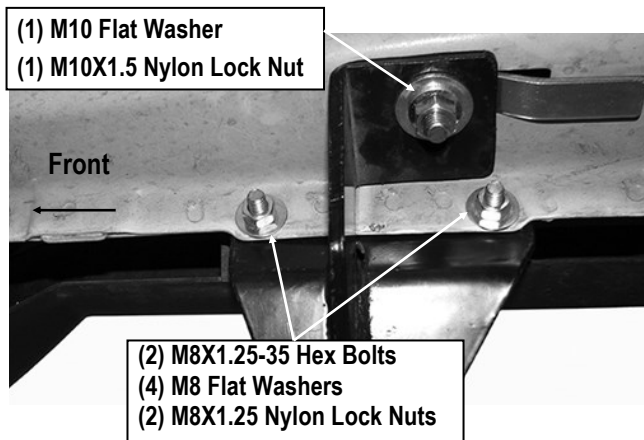

(Fig 2) Passenger Front Mounting Bracket Installed

STEP 4

Select (1) Rear Support Bracket (**DRS**), attach it to the Passenger Rear Mounting Bracket (**DRM**) with (1) M8X1.25-35 Hex Bolt, (2) M8 Flat Washers, and (1) M8X1.25 Nylon Lock Nut, (**Fig 3**). Leave the hardware loose at this time.

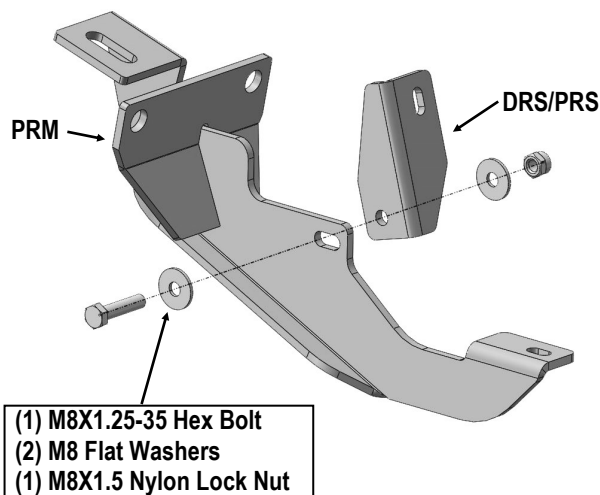

(Fig 3) Passenger Rear Mounting Bracket Assembly

STEP 5

Move to the passenger Side Rear Mounting Location, repeat **Steps 2-3** to insert (1) M10 Bolt Plate, and installed Passenger Rear Mounting Bracket (**PRM**), (**Fig 4**). Do not fully tighten at this time.

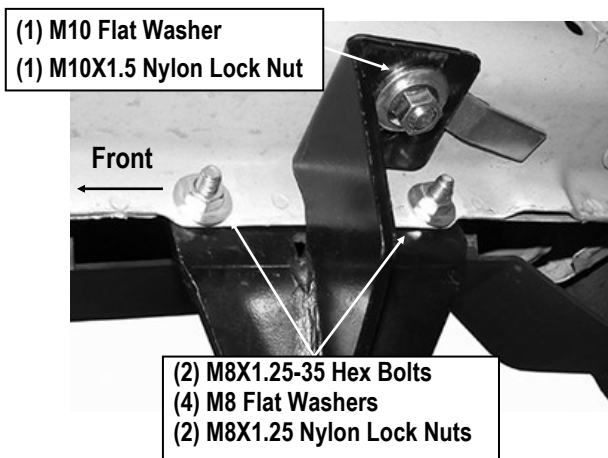

(Fig 4) Passenger Rear Mounting Bracket Installed

iArmor®

STEP 6

Once all (2) Passenger side mounting brackets are installed, attach the assembled Passenger Side Bar to the Mounting Brackets with (2) M6X1-20 T-Bolts, (2) M6X1-20 Square Head Bolts, (4) M6 Large Flat Washers and (4) M6X1 Nylon Lock Nuts, (Fig 5). Do not fully tighten hardware at this time.

STEP 7

Level and adjust the Bar properly.

NOTE: Depending on the model and year of the vehicle, the front of the running board may be too close (or interfering) with front factory flare. If necessary, insert 1 to 3 Adjustment Spacers between the Bracket and the pinch weld to adjust the side bar on a properly position, (Fig 6).

STEP 8

Once the bar is leveled properly, and then fully tighten all hardware.

Adjustment Spacers

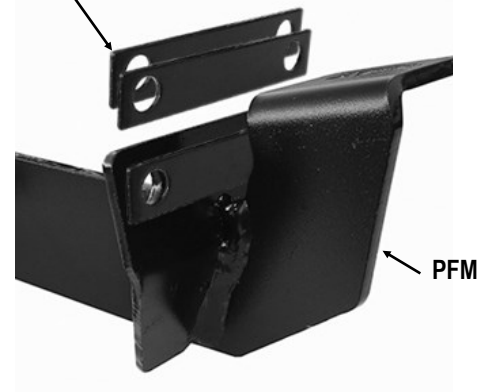

(Fig 6) Adjustment Spacers between Vehicle Pinch Weld and Mounting Bracket

STEP 9

Move to the driver side of the vehicle. Repeat Steps 2-7 to install driver side step bar.

Attention

Do periodic inspections to the installation to make sure that all hardware is secure and tight.

In order to protect your bars/boards, please use only mild soap/non-abrasive products for cleaning.

(Fig 5) Passenger Side Step Bar Installation

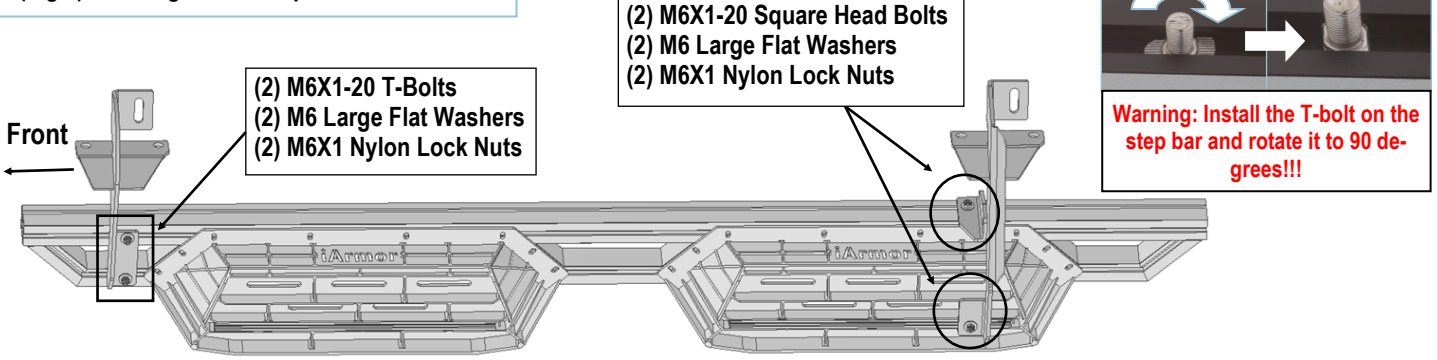

Customer Support: info@iarmorauto.com