

iArmor[®]

iArmor[®] by APS

PART#: IA-S970H

BEFORE INSTALLATION

REMOVE CONTENTS FROM BOX. VERIFY ALL PARTS ARE PRESENT. READ INSTRUCTIONS CAREFULLY BEFORE STARTING INSTALLATION. ASSISTANCE IS RECOMMENDED. THANK YOU FOR CHOOSING OUR PRODUCT!

***ROCKER PANEL MOUNT**

***NO DRILLING / TRIMMING REQUIRED**

Torque Value

Fastener Size	Tightening Torque (ft-lbs)	Required
6mm	6-7	X
8mm	16-18	√
10mm	31-32	√
12mm	56-58	X
14mm	92-94	X

PART LIST

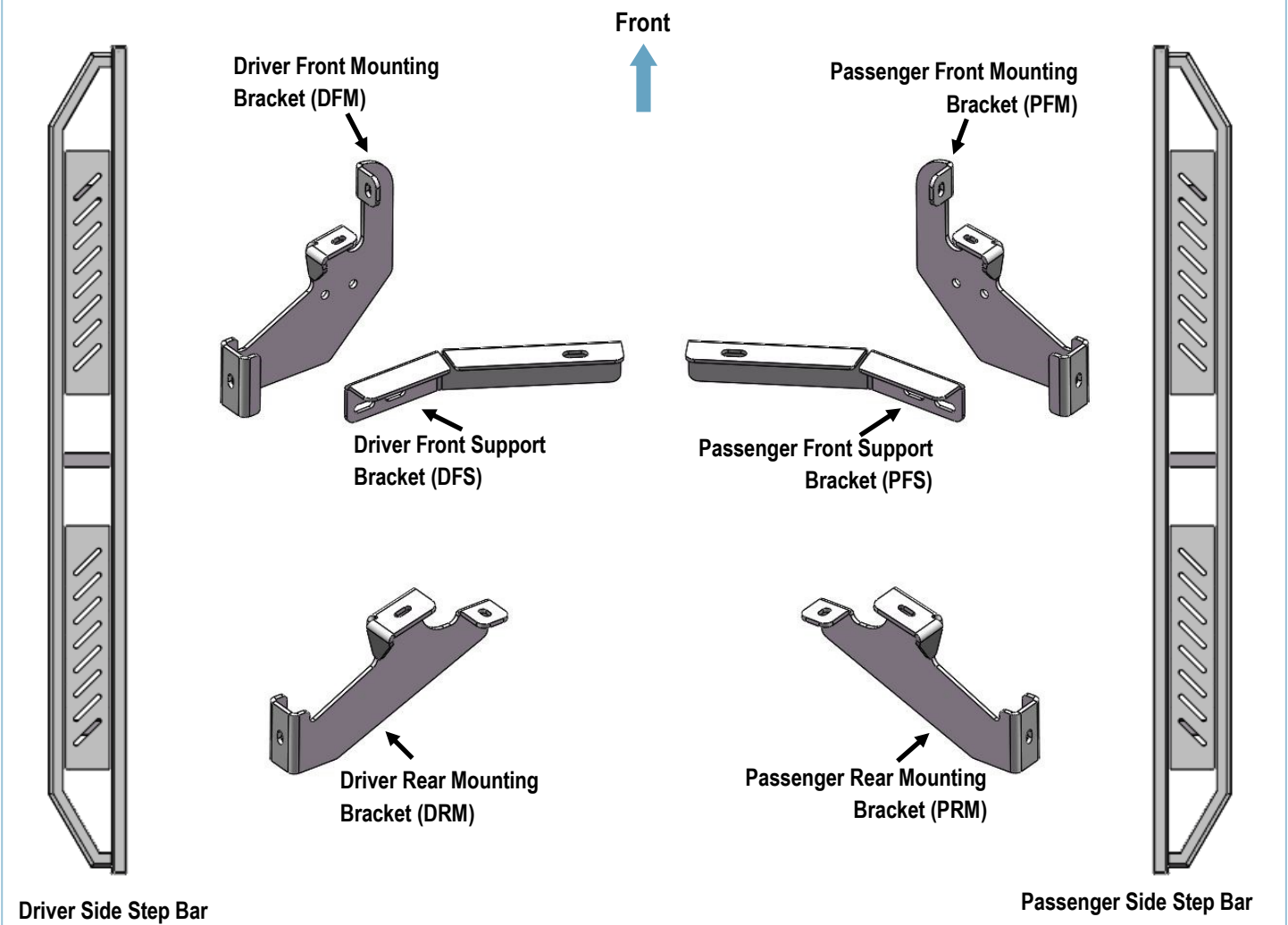

Customer Support: info@iarmorauto.com

iArmor®

Hardware Package A (For Bracket Installation)					
Item	QTY	Description	Item	QTY	Description
1#	4	U Brackets	7#	4	M8X1.25-35 Hex Bolts
2#	1	M8 Rivet Insert Installation Tool	8#	8	M8X1.25-25 Hex Bolts
3#	2	M10X35mm Bolt Plates	9#	16	M8 Large Flat Washers
4#	2	M10 Large Flat Washers	10#	12	M8 Lock Washers
5#	2	M10 Lock Washers	11#	4	M8X1.25 Hex Nuts
6#	2	M10 Hex Nuts	12#	2	M8X1.25 Rivet Insert

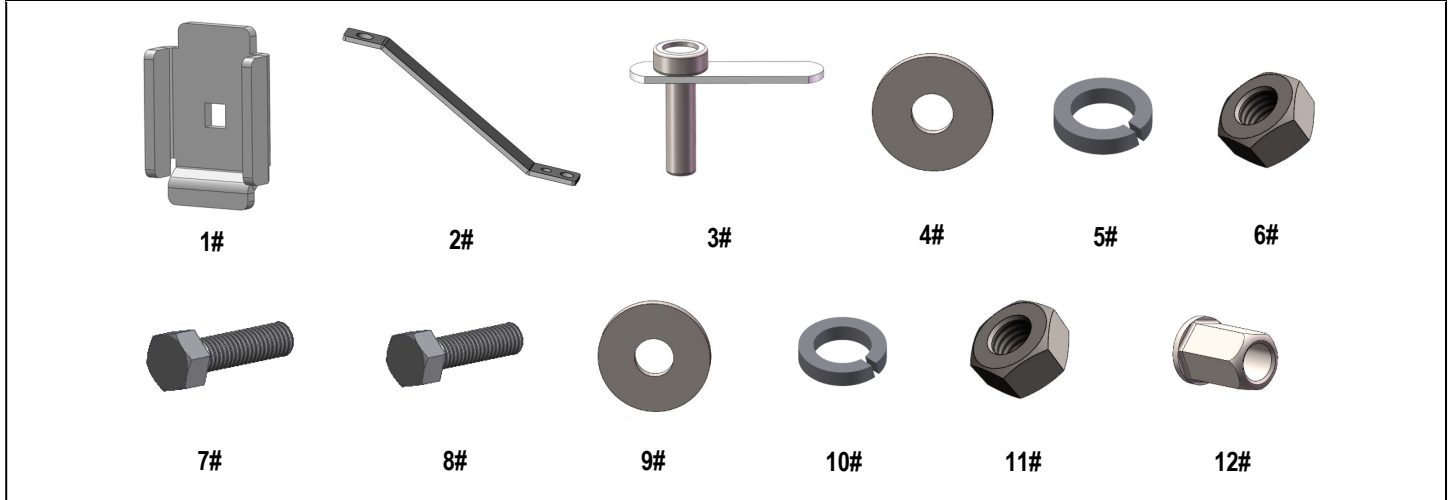

Hardware Package B (For Step Bar Installation)					
Item	QTY	Description	Item	QTY	Description
1#	4	M8X1.25-55mm Carriage Bolts	3#	4	M8 Lock Washers
2#	4	M8 Large Flat Washers	4#	4	M8 Hex Nuts

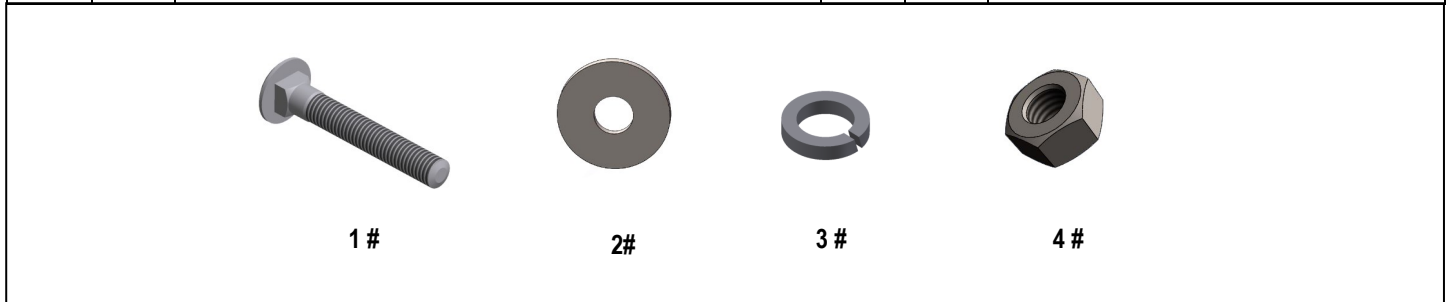

Customer Support: info@iarmorauto.com

iArmor®

The instruction here is for your reference only. We strongly recommend the professional installer for best result. We are not responsible for any damage caused by the installation.

STEP 1

Starting on the driver side front, locate the two factory 8mm threaded holes at the bottom and on the inner side of the body panel (Fig 1).

IMPORTANT: All factory threaded holes may be covered with rubber plugs or undercoating. If equipped, remove the undercoating from mounting surfaces.

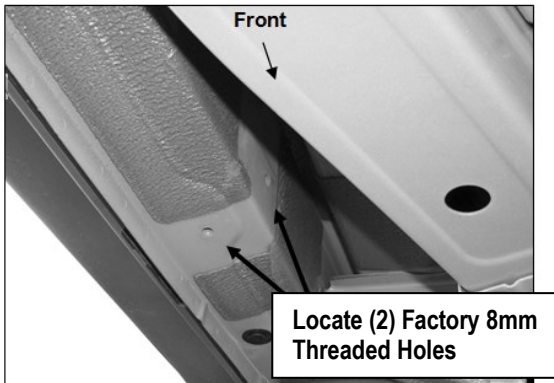

(Fig 1) Driver Side Front Mounting Location

STEP 2

Select the Driver Front Mounting Bracket (DFM). Attach the Bracket to the two threaded holes by using the provided (2) M8X1.25 -25mm Hex Bolts, (2) M8 Lock Washers and (2) M8 Large Flat Washers. Snug but do not tighten hardware at this time, (Fig 2).

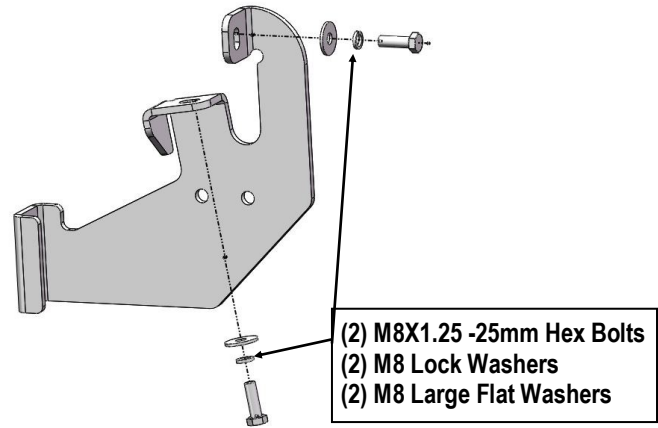

(Fig 2) Driver Front Mounting Bracket (DFM) Installation

STEP 3

Select (1) M10x35 Bolt Plate. Insert the Bolt Plate into the factory hole at the bottom of the frame channel, (Fig 3). Rotate the Bolt Plate clock-wise 90- degrees or until it stops turning.

NOTE: To determine the correct mounting hole on the frame channel, suggest line up the Driver Front Support Bracket (DFS) to the (2) holes on the Driver Front Mounting Bracket (DFM) and lined up the other end of the support bracket with the hole at the bottom of the frame channel, (Fig 4).

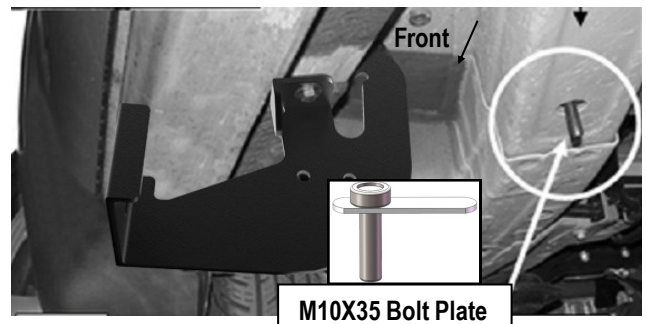

(Fig 3) Driver Front Support Bracket Mounting Location

iArmor®

STEP 4

Attach the Driver Front Support Bracket (DFS) to the Driver Front Mounting Bracket (DFM) with (2) M8x1.25-35mm Hex Bolts, (4) M8 Large Flat Washers, (2) M8 Lock Washers and (2) M8x1.25 Hex Nuts, (Fig 4). Next, bolt the Driver Front Support Bracket (DFS) to the installed M10X35 Bolt Plate with (1) M10 Large Flat Washer, (1) M10 Lock Washer and (1) M10X1.5 Hex Nut. Do not fully tighten hardware at this time.

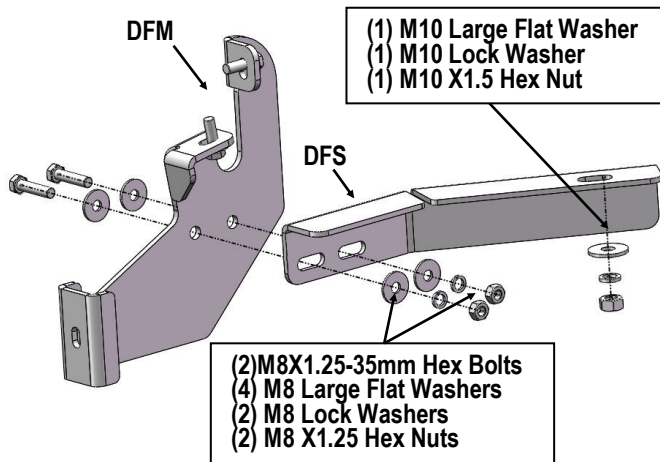

(Fig 4) Driver Front Support Bracket Installation

STEP 5

Move to the Driver Side Rear Mounting location, (Fig 5). Remove rubber plugs from the factory threaded holes as necessary. **NOTE:** To determine the correct mounting holes, suggest hold the Driver Rear Mounting Bracket (DRM) up against the factory mounting threaded holes on the frame channel. The remaining hole in mounting tab on the bracket will line up with correct factory hole in floor panel.

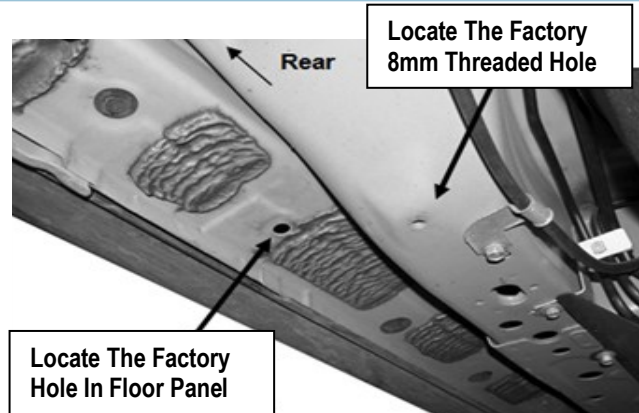

(Fig 5) Driver Side Rear Mounting Location

STEP 6

Select and assemble the M8 Rivet Insert Installation Tool, (1) M8X1.25 Rivet Insert, (1) M8 Large Flat Washer and (1) M8X1.25 -25mm Hex Bolt, (Fig 6).

NOTE: Use the 8mm hole on M8 Rivet Insert Installation Tool (Fig 7).

Insert the M8 Rivet Insert into the factory hole on floor panel. Firmly hold the tool handle and assembly up tight against the floor panel and tighten the M8X1.25-25mm Hex Bolt until the insert rivet is fully expanded in the hole, (Fig 8).

NOTE: Do not over tighten or a pull out may occur. Once Insert is fully compressed, remove the bolt and tool from the Insert.

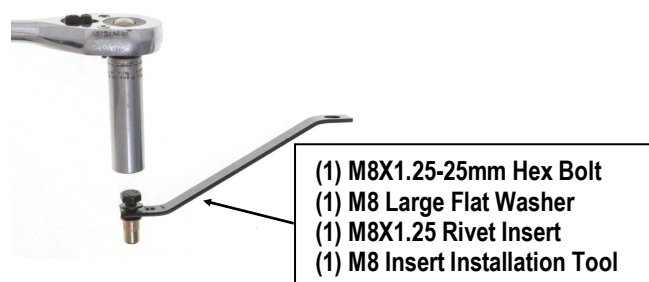

(Fig 6) M8 Rivet Insert Installation Tool Assembly

iArmor®

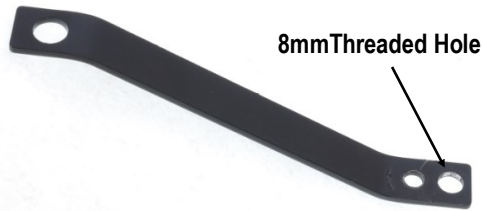

(Fig 7) M8 Rivet Insert Installation Tool



(Fig 8) Tighten Hex Bolt To Collapse And Lock Rivet Insert Into Factory Hole

STEP 7

Attach the Driver Rear Mounting Bracket (DRM) to the factory 8mm threaded hole on the frame channel and the installed M8 Rivet Insert with (2) M8X1.25 -25mm Hex Bolts, (2) M8 Lock Washers and (2) M8 Large Flat Washers, (Fig 9). Do not tighten hardware at this time.

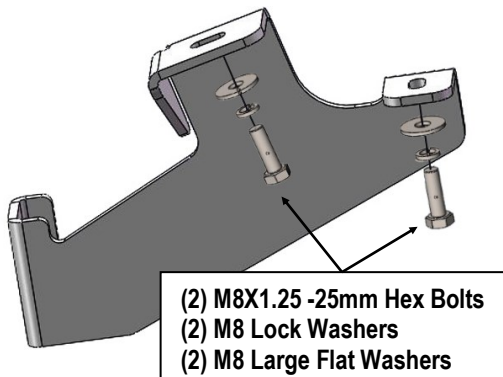

(Fig 9) Driver Rear Mounting Bracket (DRM) Installation

STEP 8

Once all (2) driver side mounting brackets are installed, select and attach the Driver Side Step Bar onto the Mounting Brackets with (2) U Brackets, (2) M8X1.25-55mm Carriage Bolts, (2) M8 Large Flat Washers, (2) M8 Lock Washers and (2) M8X1.25 Hex Nuts (Fig 10). Do not fully tighten hardware at this time.

Properly level and adjust the Step Bar and fully tighten all hardware.

STEP 9

Move to the passenger side of the vehicle. Repeat Steps 1-8 to install passenger side step bar.

Installation completed.

Attention

Do periodic inspections to the installation to make sure that all hardware is secure and tight.

In order to protect your bars/boards, please use mild soap/non-abrasive products for cleaning only.

iArmor[®]

NOTE: Torque all M8 X1.25-55mm Carriage Bolts to 16~18 lb-ft. Don't over tighten, or the square bars will be damaged by the brackets

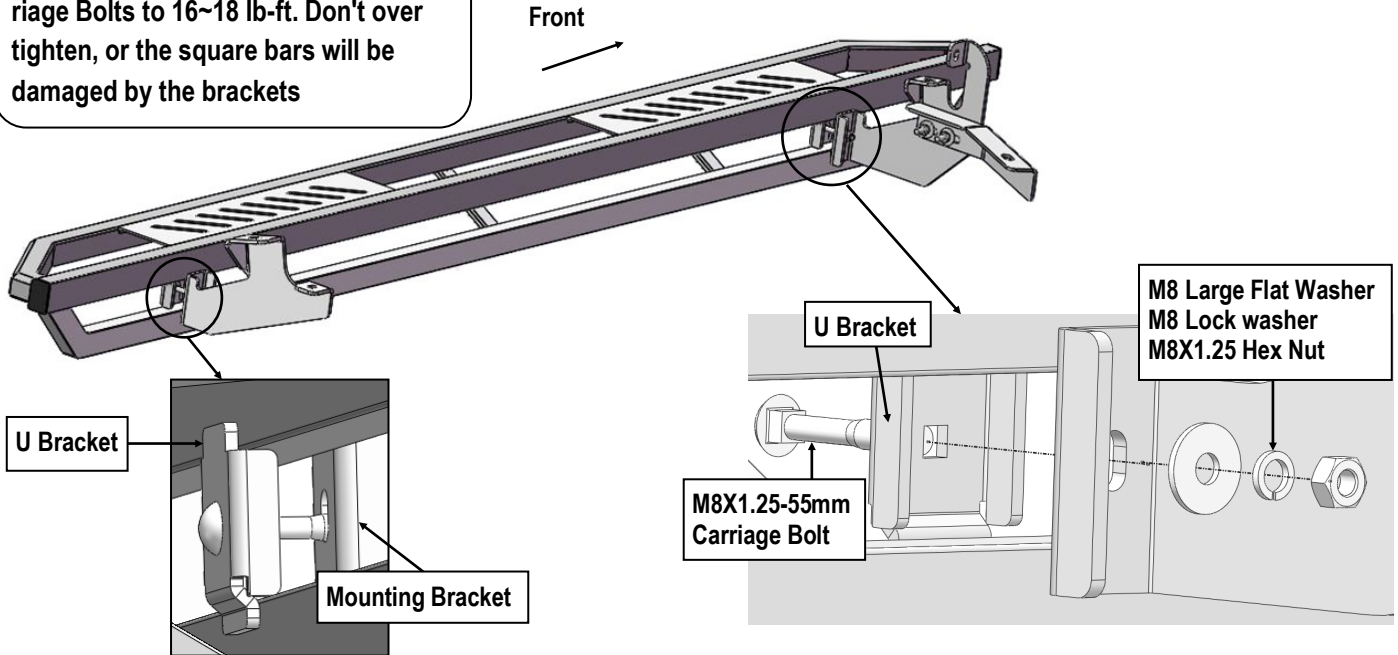

(Fig 10) Driver Side Step Bar Installation