

IARMOR EDGE™

PART#: IA-N941

BEFORE INSTALLATION

REMOVE CONTENTS FROM BOX. VERIFY ALL PARTS ARE PRESENT. READ INSTRUCTIONS CAREFULLY BEFORE STARTING INSTALLATION. ASSISTANCE IS RECOMMENDED. THANK YOU FOR CHOOSING OUR PRODUCT!

*DRILLING NOT REQUIRED / CUTTING IS REQUIRED

*TRIMMING NOT REQUIRED

Fastener Size	Tightening Torque (ft-lbs)	Required
6mm	6-7	√
8mm	16-18	√
10mm	31-32	X
12mm	56-58	X
14mm	92-94	X

Item	QTY	Description	Item	QTY	Description
1#	2	Driver Front & Rear Mounting Brackets	8#	24	M8 Hex Nuts
2#	2	Passenger Front & Rear Mounting Brackets	9#	8	M8X1.25-20mm Inner Hex Bolts
3#	2	Driver Front & Rear Bar Brackets	10#	8	M8 Hex Flange Nuts
4#	2	Passenger Front & Rear Bar Brackets	11#	8	M6X1-20mm Square Head Bolts
5#	24	M8X1.25-35mm Hex Bolts	12#	40	M6 Large Flat Washers
6#	24	M8 Flat Washers	13#	40	M6 Nylon Lock Nuts
7#	24	M8 Lock Washers	14#	32	M6X1-20mm T-Bolts

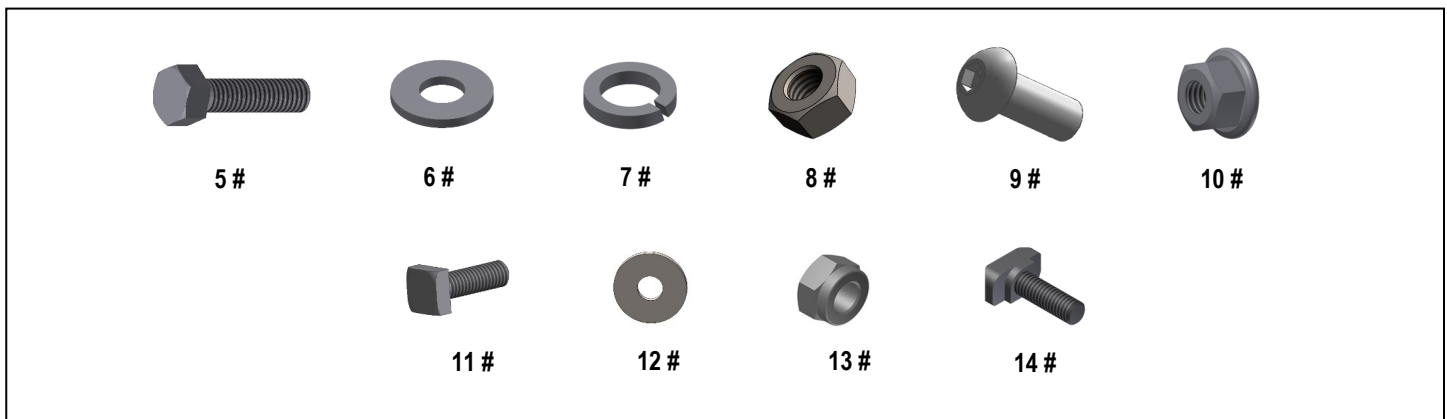

iArmor[®]

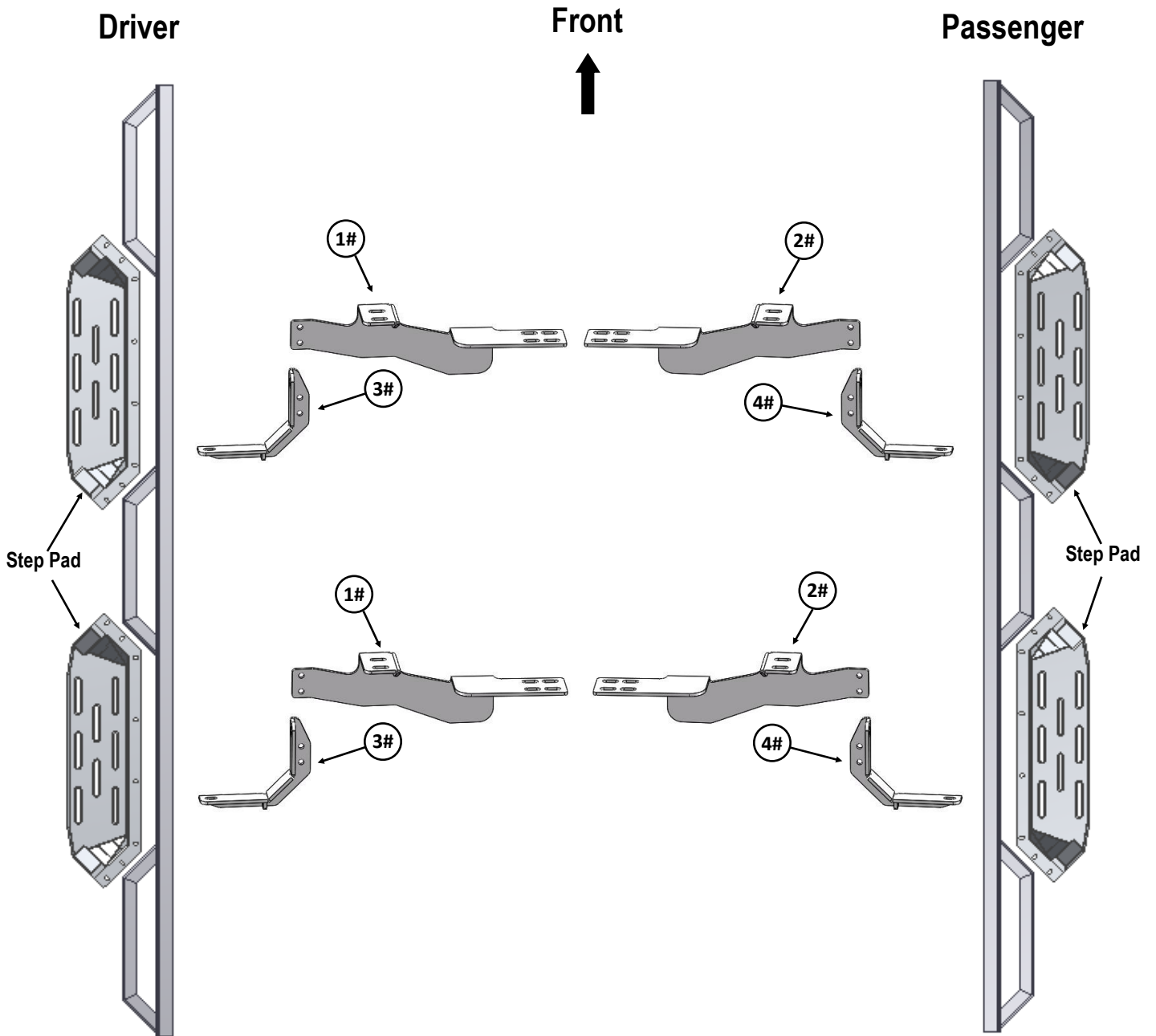

iArmor®

The instruction here is for your reference only. We strongly recommend the professional installer for best result. We are not responsible for any damage caused by the installation.

STEP 1

Install the Step Pads onto the step bars with (32) M6x1-20mm T-Bolts, (32) M6 Flat Washers and (32) M6 Nylon Lock Nuts.

IMPORTANT: Don't hit the step pad by any metal hammer within step pad installation, or the step pad will be damaged.

(8) M6X1-20mm T-Bolts
(8) M6 Flat Washers
(8) M6 Nylon Lock Nuts

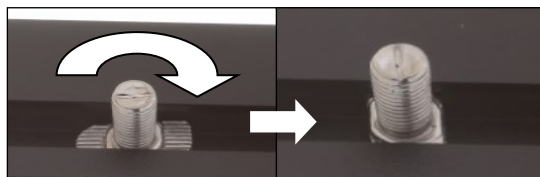
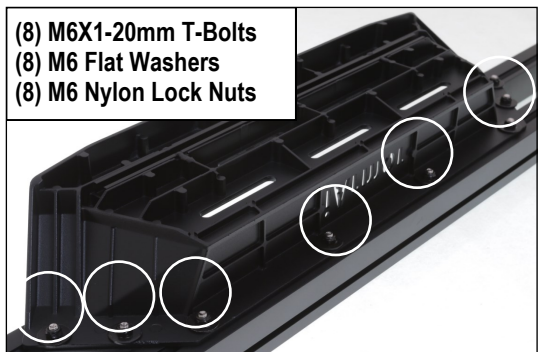

Note: Rotate 90° after inserting the T-Bolts into the Channel!!!

STEP 2

Start installation from the driver side front of the vehicle. From underneath vehicle, place driver side front bracket in position as shown in (Fig 1).



(Fig 1) Driver Side Front Mounting Location

STEP 3

Select (1) Driver Front Mounting Bracket and Driver Front Bar Bracket, assemble with (2) M8X1.25-20mm Inner Hex Bolts and (2) M8 Hex Flange Nuts, (Fig 2). Do not fully tighten hardware at this time.

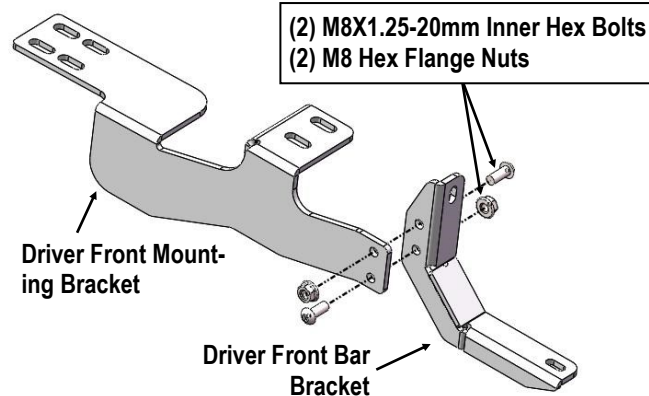

(Fig 2) Driver Front Brackets Assembly

STEP 4

Attach the assembled Driver Front Mounting Bracket to driver side front location with (6) M8x1.25-35mm Hex Bolts, (6) M8 Flat Washers, (6) M8 Lock Washers, (6) M8 Hex Nuts, (Fig 3). Do not fully tighten hardware at this time.

iArmor®

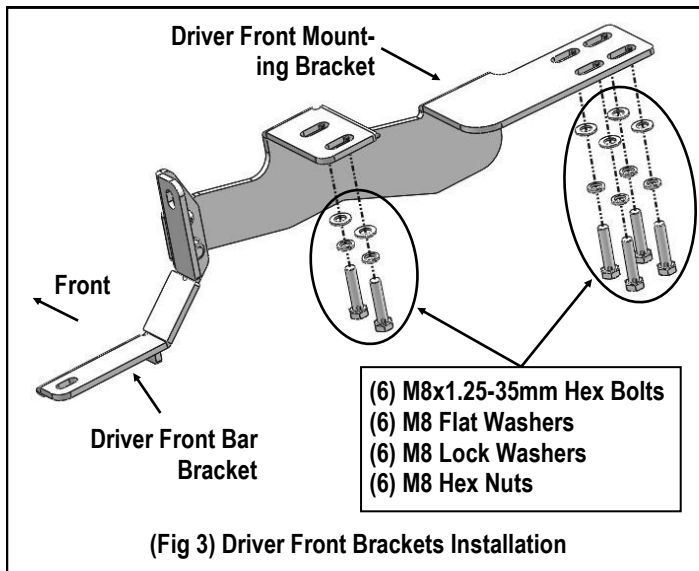

STEP 5

Repeat **Steps 2-4** for Driver Rear Mounting Bracket and Driver Rear Bar Bracket assemble and installation. Do not fully tighten hardware at this time.

STEP 6

Once all (2) Driver side mounting brackets are installed, select and attach the Driver Side Step Bar onto the Mounting Brackets with (4) M6X1-20mm Square Head Bolts, (4) M6 Large Flat Washers and (4) M6 Nylon Lock Nuts, (**Fig 4**). Do not fully tighten hardware at this time.

STEP 7

Properly level and adjust the Step Bar and fully tighten all hardware.

STEP 8

Move to the other side of the vehicle. Repeat **Steps 2—7** for other side Step Bar installation.

Attention

Do periodic inspections to the installation to make sure that all hardware is secure and tight.
In order to protect your bars/boards, please use only mild soap/non-abrasive products for cleaning.

(Fig 4) Driver Side Step Bar Installation

