

iArmor®

IARMOR EDGE™

PART#: IA-W189

BEFORE INSTALLATION

REMOVE CONTENTS FROM BOX. VERIFY ALL PARTS ARE PRESENT. READ INSTRUCTIONS CAREFULLY BEFORE STARTING INSTALLATION. ASSISTANCE IS RECOMMENDED. THANK YOU FOR CHOOSING OUR PRODUCT!

*ROCKER PANEL MOUNT

*DRILLING / TRIMMING NOT REQUIRED

Fastener Size	Tightening Torque (ft-lbs)	Required
6mm	6-7	X
8mm	16-18	√
10mm	31-32	√
12mm	56-58	X
14mm	92-94	X

Driver

Front

Passenger

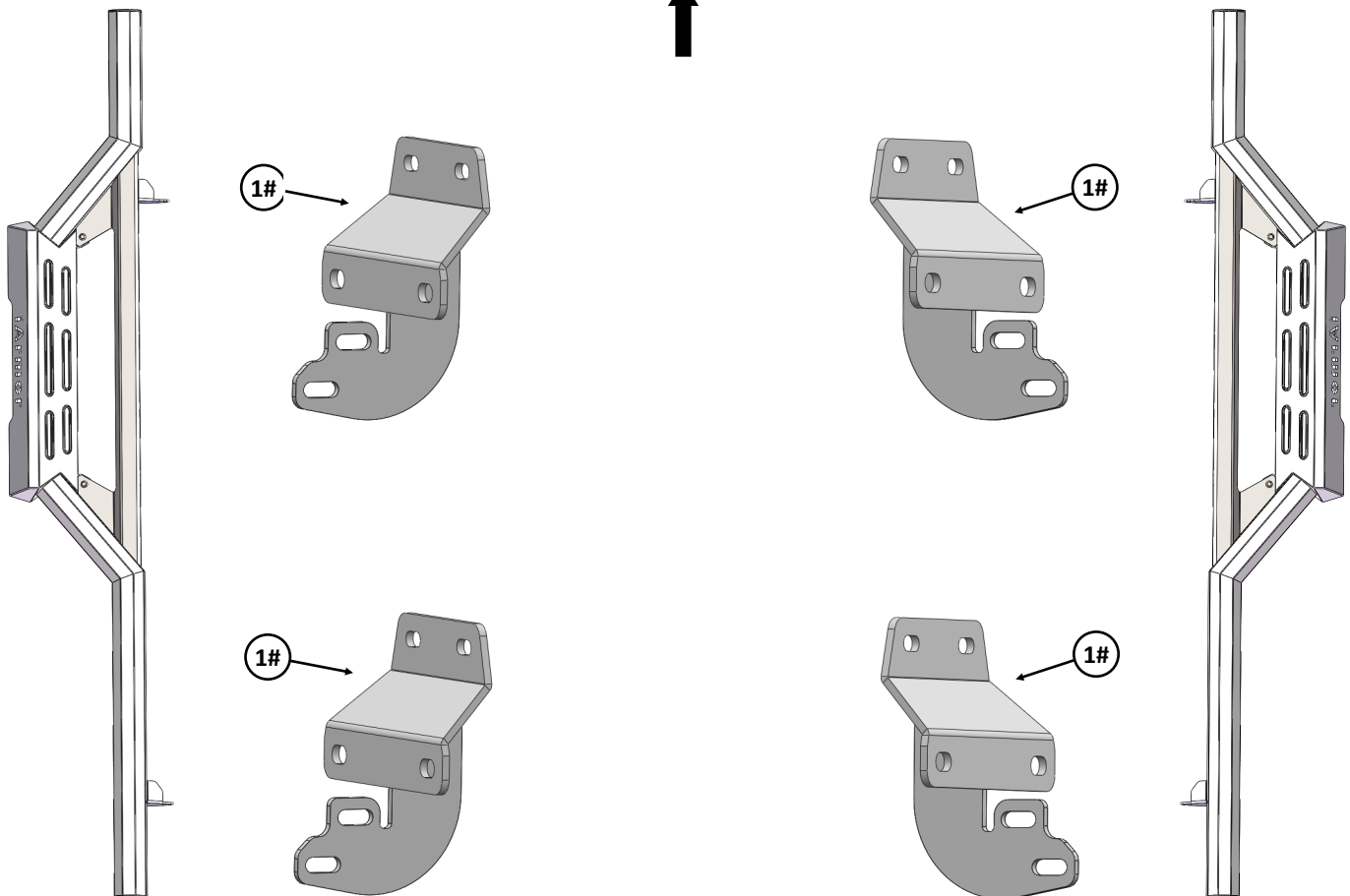

iArmor[®]

Hardware Package (For Brackets & Step Bars Installation)

Item	QTY	Description	Item	QTY	Description
1#	4	Mounting Brackets	5#	8	M10X1.5-25 Hex Bolts
2#	12	M8 Plastic Washers	6#	16	M10 Flat Washers
3#	12	M8 Large Flat Washers	7#	8	M10X1.5 Nylon Lock Nuts
4#	12	M8X1.25 Nylon Lock Nuts			

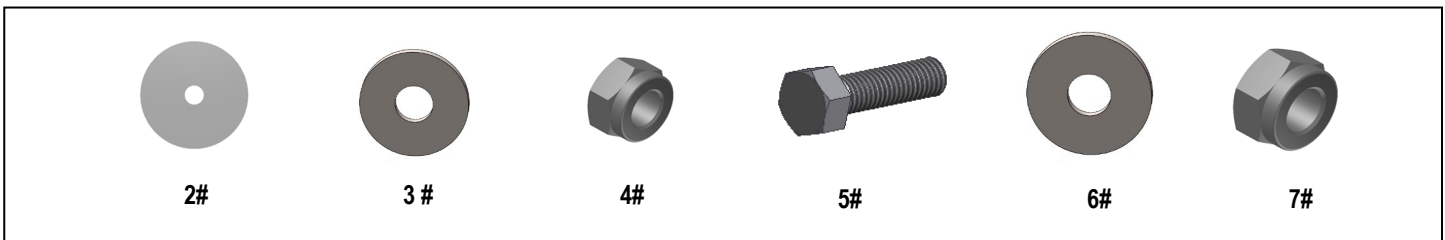

iArmor®

The instruction here is for your reference only. We strongly recommend the professional installer for best result. We are not responsible for any damage caused by the installation.

STEP 1

Starting from the Driver front of the vehicle, locate the threaded mounting studs in the rocker panel, **(Fig 1)**. **Clean mounting studs with wire brush to remove paint and debris.**

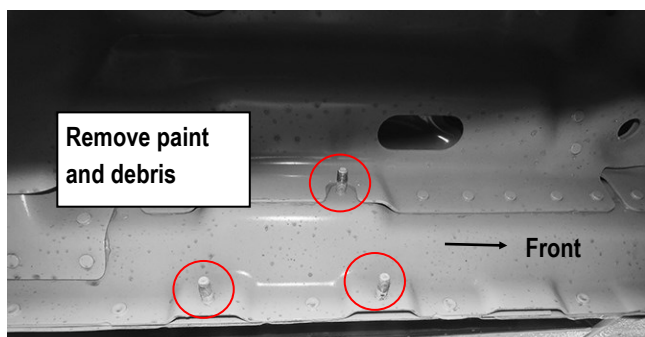

(Fig 1) Driver Side Front Mounting Location

STEP 2

Slide (3) M8 Plastic Washers over the (3) factory mounting studs on the rocker panel.

NOTE: The Plastic Washers are designed to prevent corrosion between the aluminum rocker panel and the steel mounting brackets.

STEP 3

Select (1) mounting bracket, attach the mounting bracket to the driver side front mounting location with (3) M8 Flat Washers and (3) M8X1.25 Nylon Lock Nuts, **(Fig 3)**. Do not fully tighten hardware at this time.

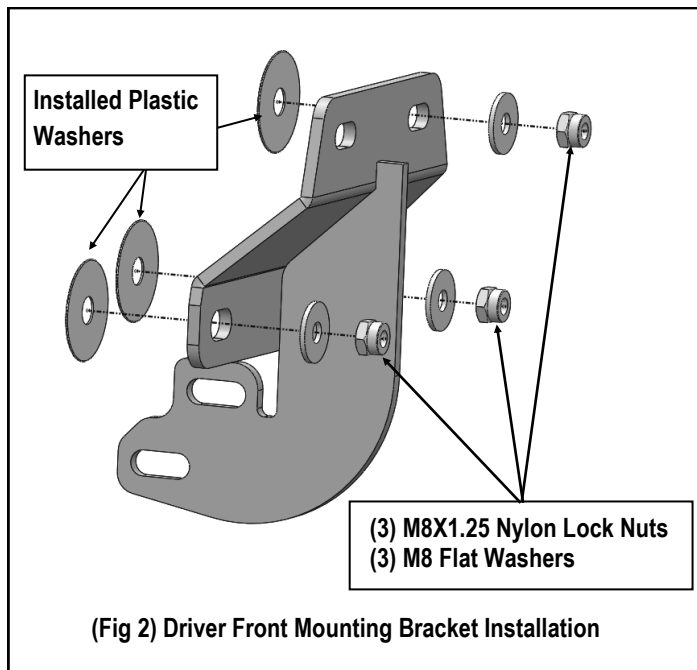

STEP 4

Move to Driver Side Rear Mounting Location **(Fig 3)**. Repeat **Steps 2-3** to install the Driver Rear Mounting Bracket. Do not fully tighten hardware at this time.

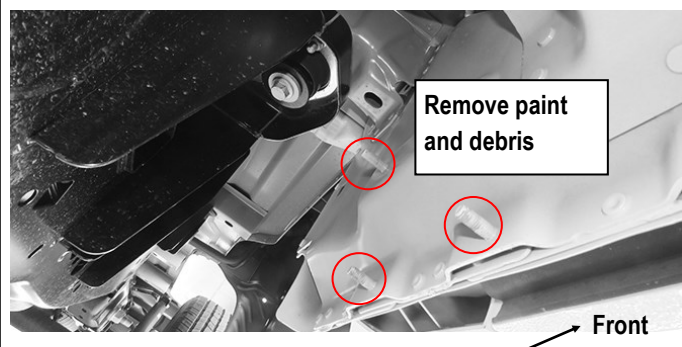

(Fig 3) Driver Side Rear Mounting Location

iArmor®

STEP 5

Once all (2) Driver Side Mounting Brackets have been installed, attach the Driver Side Step Bar to the Mounting Brackets with (4) M10X1.5-25 Hex Bolts, (8) M10 Flat Washers and (4) M10X1.5 Nylon Lock Nuts, (**Fig 4**). Properly level and adjust the Step Bar and fully tighten all hardware.

STEP 6

Move to the other side of the vehicle. Repeat **Steps 1-5** to install the other side step bar.

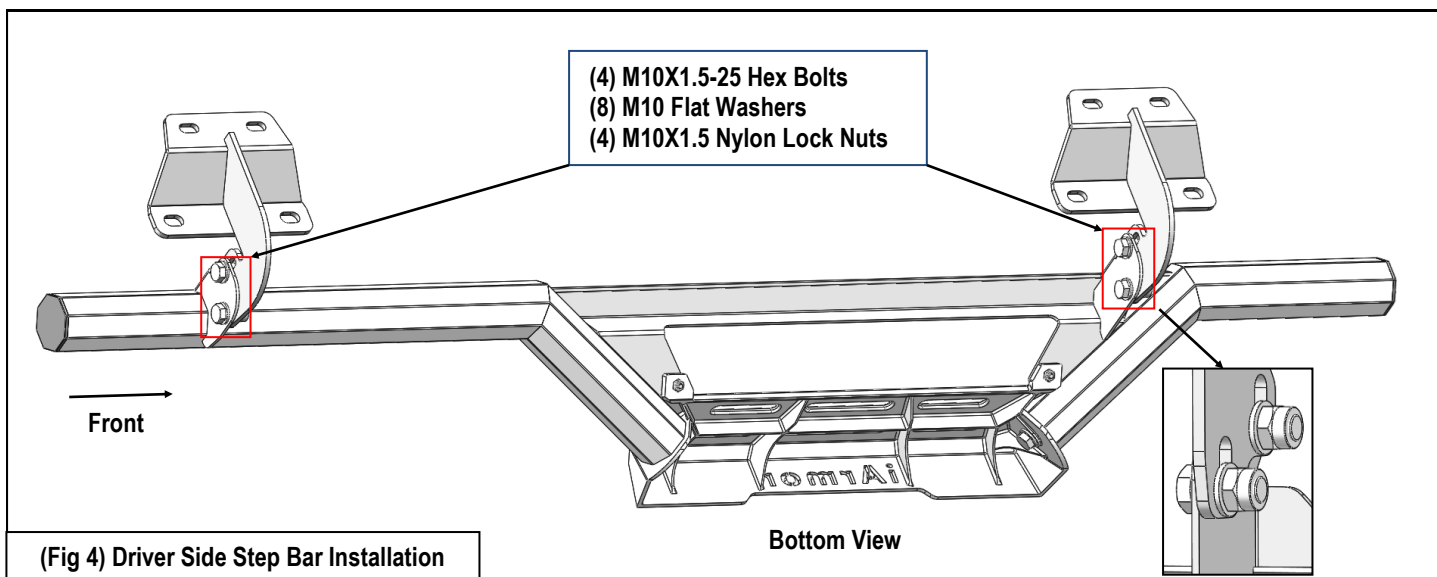

Attention

Do periodic inspections to the installation to make sure that all hardware is secure and tight.
In order to protect your bars/boards, please use mild soap/non-abrasive products for cleaning only.