

# iArmor<sup>®</sup>

## iArmor<sup>®</sup> by APS

PART#: IA-S003&S011

### BEFORE INSTALLATION

REMOVE CONTENTS FROM BOX. VERIFY ALL PARTS ARE PRESENT. READ INSTRUCTIONS CAREFULLY BEFORE STARTING INSTALLATION. ASSISTANCE IS RECOMMENDED. THANK YOU FOR CHOOSING OUR PRODUCT!

\*ROCKER PANEL MOUNT

\*NO DRILLING /TRIMMING REQUIRED

Fastener Size	Tightening Torque (ft-lbs)	Required
6mm	6-7	X
8mm	16-18	√
10mm	31-32	X
12mm	56-58	X
14mm	92-94	X

Item	QTY	Description	Item	QTY	Description
1#	3	Driver Front / Center / Rear Mounting Brackets	7#	6	M8X1.25 Nylon Lock Nuts
2#	3	Passenger Front / Center / Rear Mounting Brackets	8#	6	M8 Clip Nuts
3#	6	U Brackets	9#	6	M8X1.25-55mm Carriage Bolts
4#	12	Spacers	10#	6	M8 Lock Washers
5#	12	M8X1.25-25mm Hex Bolts	11#	6	M8X1.25 Hex Nuts
6#	26	M8 Large Flat Washers			

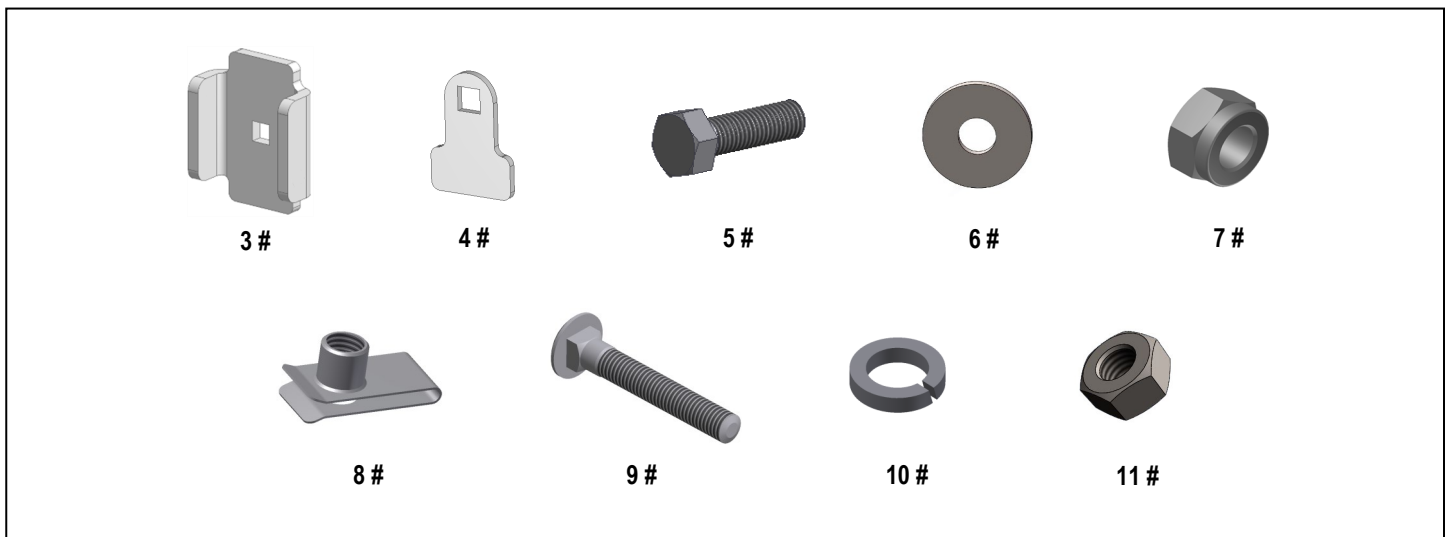

# iArmor<sup>®</sup>

Driver

Front



Passenger

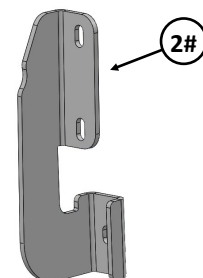
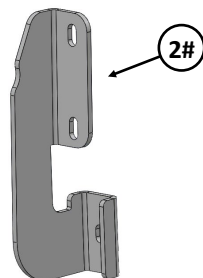
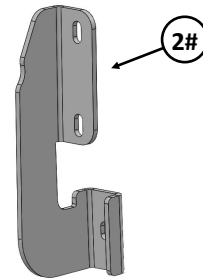
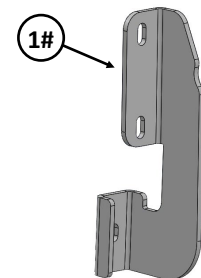
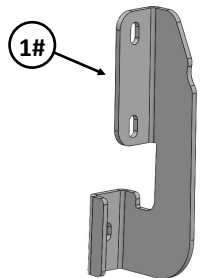
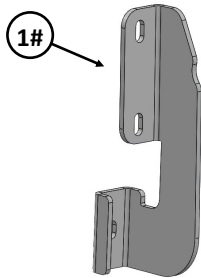
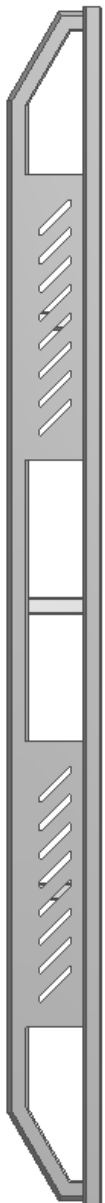

# iArmor®

The instruction here is for your reference only. We strongly recommend the professional installer for best result. We are not responsible for any damage caused by the installation.

## STEP 1

Starting on the passenger side of the vehicle, locate the (2) holes through the bottom of the body panel, (pinch weld). Next locate the rectangular opening and (2) small holes in the inner body panel directly above the holes in the pinch weld, (Figs 1 & 2). **NOTE:** The holes in the inner panel may be covered with sealing tape or insulation, remove as required.

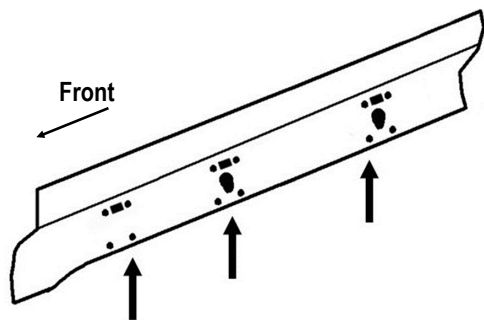

(Fig 1) Passenger Side Mounting Area Illustrated For Instruction Purposes

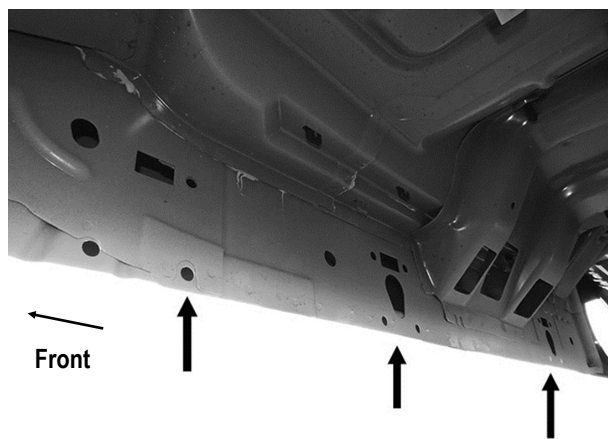

(Fig 2) Passenger Side Mounting Location Pictured

## STEP 2

Slide (1) M8 Clip Nut into the rectangular opening with the nut towards the inside. Line up the threaded nut on the clip with the round hole toward the rear, (Fig 3).

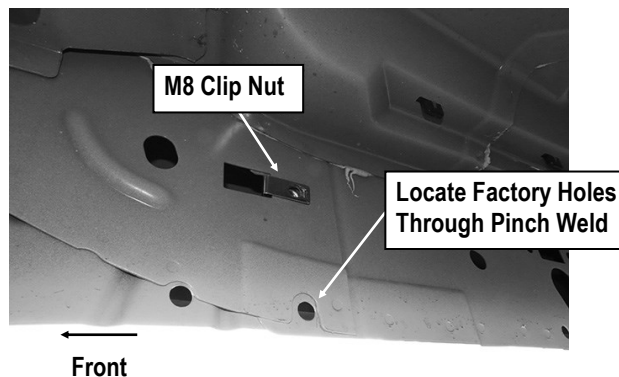

(Fig 3) Slide M8 Clip Nut Into Rectangular Opening

## STEP 3

Select (1) Passenger Front Mounting Bracket. Attach the top of the Bracket to the M8 Clip Nut with (1) M8X1.25-25mm Hex Bolt and (1) M8 Flat Washer, (Fig 4). Do not fully tighten hardware at this time.

Line up the lower hole in the Bracket with the hole through the pinch weld. Bolt the Bracket to the pinch weld with (1) M8X1.25-25mm Hex Bolt, (2) M8 Flat Washers and (1) M8X1.25 Nylon Lock Nut, (Fig 4). Snug but do not fully tighten Bracket hardware.

## STEP 4

Repeat **Steps 1-3** for Passenger Center & Rear Mounting Brackets installation. Do not fully tighten hardware at this time.

# iArmor®

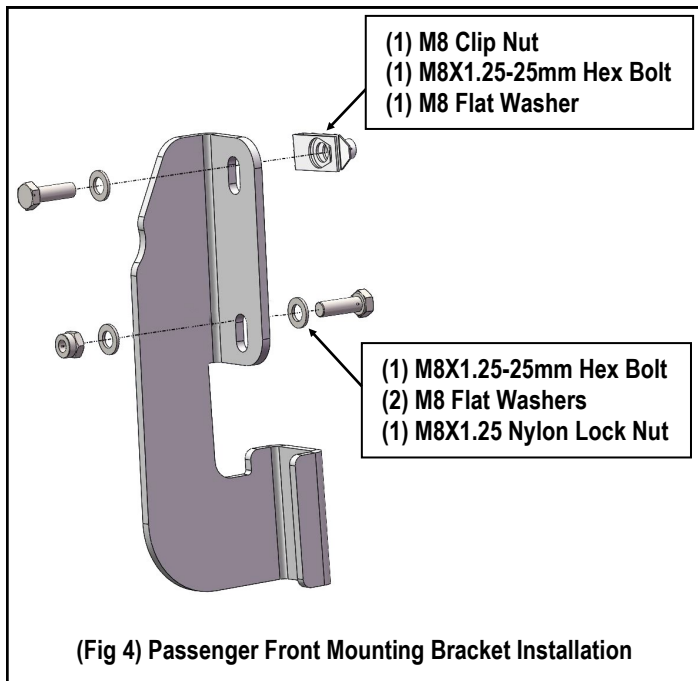

## STEP 5

Once all (3) passenger side mounting brackets are installed, select and attach the Passenger Side Step Bar onto the Mounting Brackets with (3) U Brackets, (6) Spacers, (3) M8X1.25-55mm Carriage Bolts, (3) M8 Large Flat Washers, (3) M8 Lock Washers and (3) M8X1.25 Hex Nuts, (Fig 5). Do not fully tighten hardware at this time.

## STEP 6

Properly level and adjust the Step Bar and fully tighten all hardware.

## STEP 7

Move to the driver side of the vehicle. Repeat **Steps 1-6** to install the driver side step bar.

Installation completed.

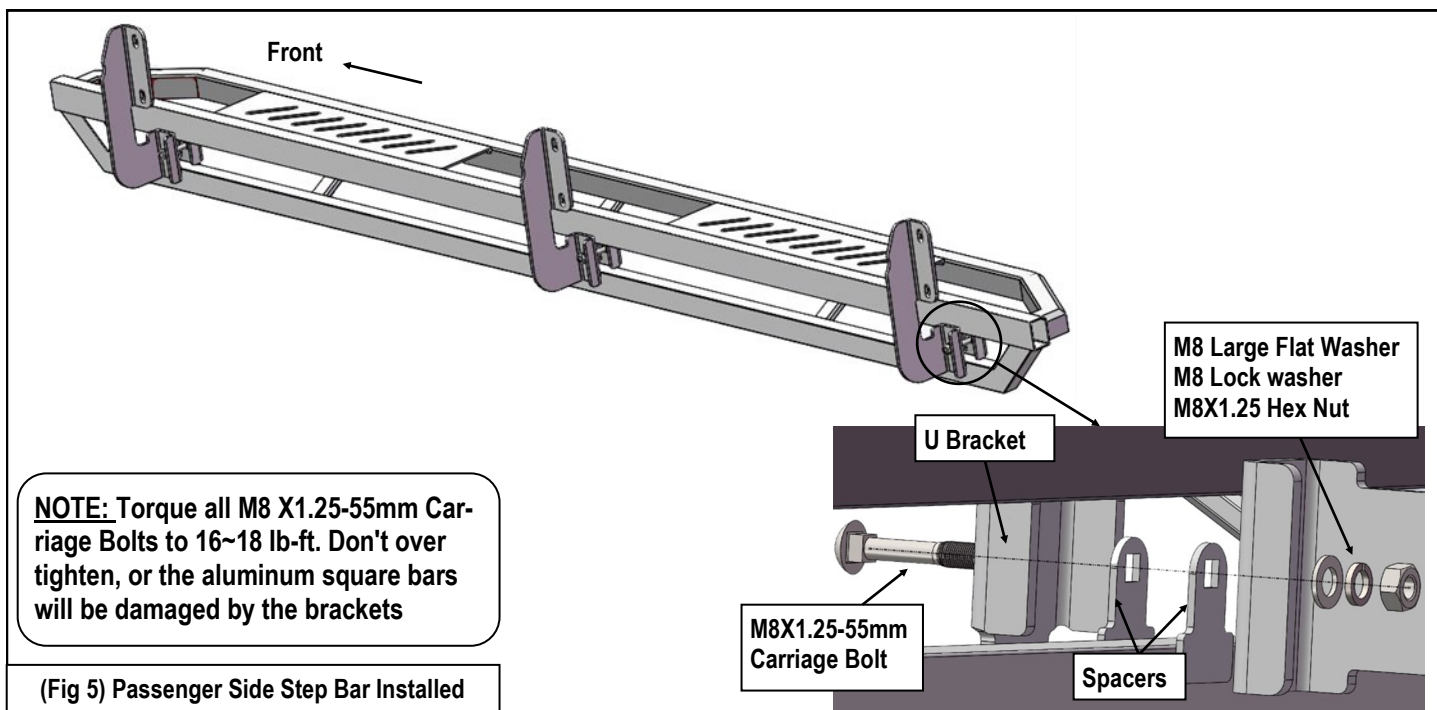

### Attention

Do periodic inspections to the installation to make sure that all hardware is secure and tight. In order to protect your bars/boards, please use only mild soap/non-abrasive products for cleaning.