

# iArmor<sup>®</sup>

## iArmor<sup>®</sup> by APS

PART#: IA-S042H

### BEFORE INSTALLATION

REMOVE CONTENTS FROM BOX. VERIFY ALL PARTS ARE PRESENT. READ INSTRUCTIONS CAREFULLY BEFORE STARTING INSTALLATION. ASSISTANCE IS RECOMMENDED. THANK YOU FOR CHOOSING OUR PRODUCT!

\*ROCKER PANEL MOUNT

\*NO DRILLING / TRIMMING REQUIRED

### Torque Value

| Fastener Size | Tightening Torque (ft-lbs) | Required |
|---------------|----------------------------|----------|
| 6mm           | 6-7                        | X        |
| 8mm           | 16-18                      | √        |
| 10mm          | 31-32                      | √        |
| 12mm          | 56-58                      | X        |
| 14mm          | 92-94                      | X        |

### PART LIST

#### Driver Side Step Bar

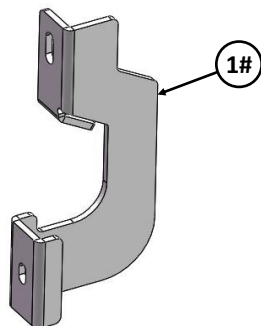
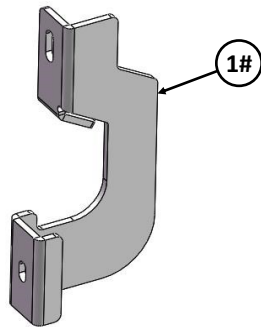

Front



#### Passenger Side Step Bar

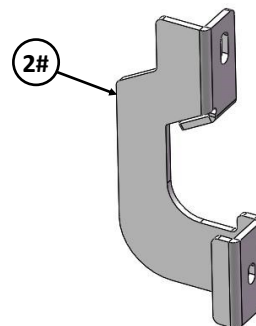
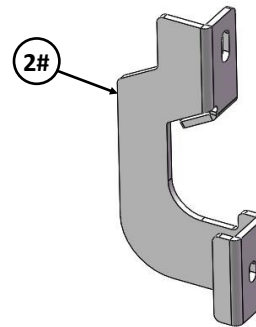
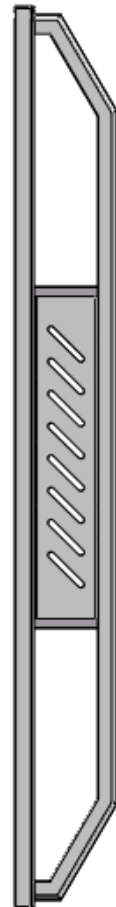

| Hardware Package A (For Bracket Installation) |     |  |      |     |                        |
|---|-----|--|------|-----|------------------------|
| Item  | QTY | Description                              | Item | QTY | Description            |
| 1#  | 2   | Driver Front & Rear Mounting Brackets    | 7#   | 4   | M8 Clip Nuts           |
| 2#  | 2   | Passenger Front & Rear Mounting Brackets | 8#   | 4   | M10X1.5-25mm Hex Bolts |
| 3#  | 4   | U Brackets                               | 9#   | 8   | M10 Flat Washers       |
| 4#  | 4   | M8X1.25-25mm Hex Bolts                   | 10#  | 4   | M10 Lock Washers       |
| 5#  | 4   | M8 Large Flat Washers                    | 11#  | 4   | M10 Hex Nuts           |
| 6#  | 4   | M8 Lock Washers                          |      |     |                        |

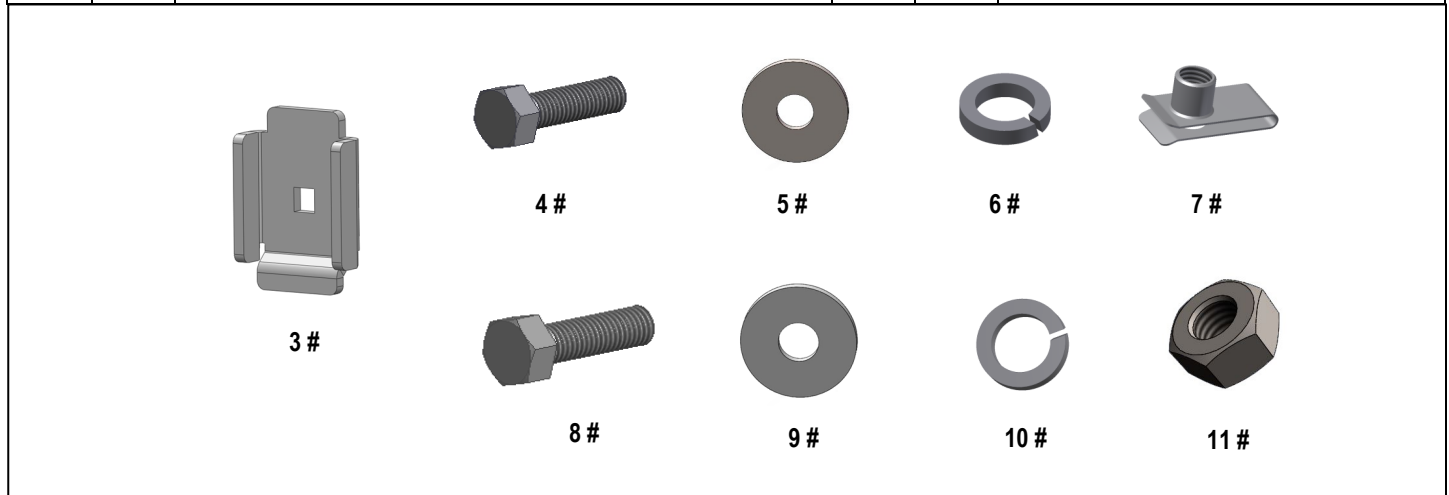

| Hardware Package B (For Step Bar Installation) |     |                             |      |     |                 |
|--|-----|-----------------------------|------|-----|-----------------|
| Item   | QTY | Description                 | Item | QTY | Description     |
| 1#   | 4   | M8X1.25-55mm Carriage Bolts | 3#   | 4   | M8 Lock Washers |
| 2#   | 4   | M8 Large Flat Washers       | 4#   | 4   | M8 Hex Nuts     |

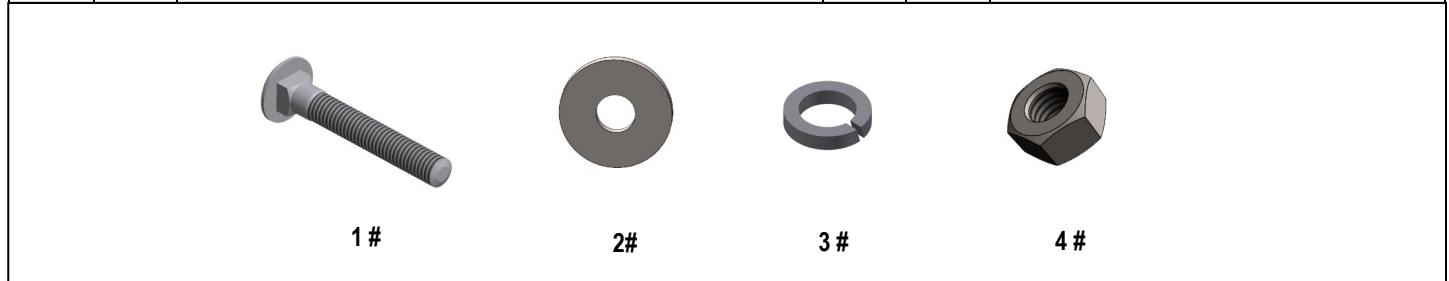

# iArmor®

The instruction here is for your reference only. We strongly recommend the professional installer for best result. We are not responsible for any damage caused by the installation.

## STEP 1

Start installation from the passenger side of the vehicle. Locate Passenger Side mounting locations as shown on **Fig 1**.

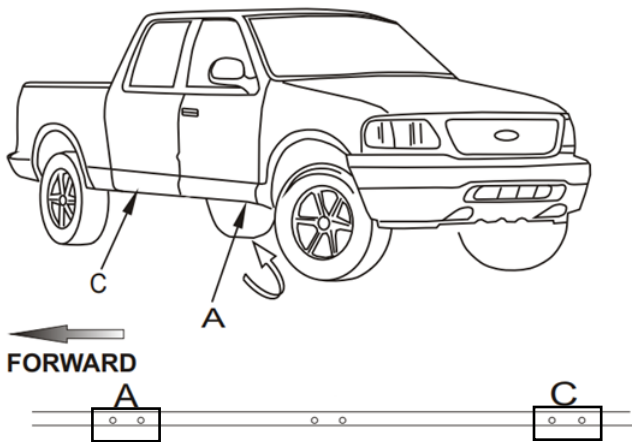

(Fig 1) Passenger Side Mounting Locations

## STEP 2

Start from the passenger front mounting location. Select (1) M8 Clip Nut. Install M8 Clip Nut as shown, (**Fig 2**).

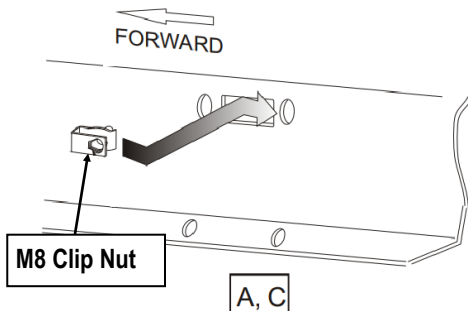

(Fig 2) M8 Clip Nut Installation

- (1) M8X1.25-25mm Hex Bolt
- (1) M8 Flat Washer
- (1) M8 Lock Washer

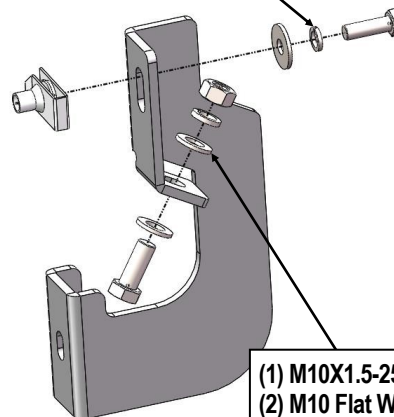

- (1) M10X1.5-25mm Hex Bolt
- (2) M10 Flat Washers
- (1) M10 Lock Washer
- (1) M10 Hex Nut

(Fig 3) Passenger Front Mounting Bracket Installation

## STEP 3

Attach (1) Passenger Front Mounting Bracket to the installed M8 Clip Nut with (1) M8X1.25-25mm Hex Bolt, (1) M8 Flat Washer, (1) M8 Lock Washer; to pinch weld with (1) M10X1.5-25mm Hex Bolt, (2) M10 Flat Washers, (1) M10 Lock Washer, (1) M10 Hex Nut, (**Fig 3**). Do not fully tighten hardware at this time.

## STEP 4

Move to the passenger side rear of the vehicle. Select (1) Passenger Rear Mounting Bracket. Repeat **Steps 1—3** to install the passenger side Rear Mounting Brackets.

# iArmor®

## STEP 5

Once all (2) passenger side mounting brackets are installed, select and attach the Passenger Side Step Bar onto the Mounting Brackets with (2) U Brackets, (2) M8X1.25-55mm Carriage Bolts, (2) M8 Large Flat Washers, (2) M8 Lock Washers and (2) M8 Hex Nuts (**Fig 4**). Do not fully tighten hardware at this time.

## STEP 6

Properly level and adjust the Step Bar and fully tighten all hardware.

## STEP 7

Move to the driver side of the vehicle. Repeat **Steps 1-6** to install the driver side step bar.

Installation completed.

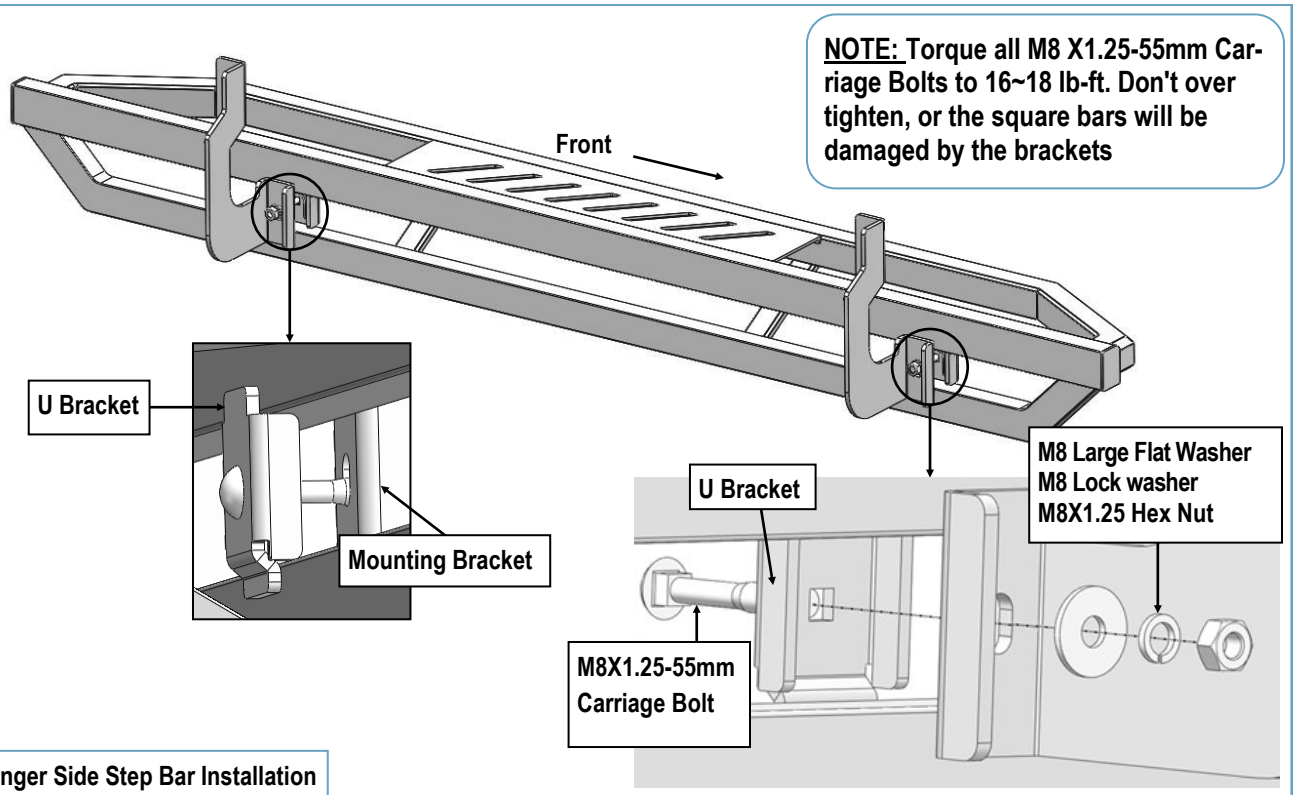

### Attention

Do periodic inspections to the installation to make sure that all hardware is secure and tight.  
In order to protect your bars/boards, please use mild soap/non-abrasive products for cleaning only.