

iArmor[®]

iArmor[®] by APS

PART#: IA-S039

BEFORE INSTALLATION

REMOVE CONTENTS FROM BOX. VERIFY ALL PARTS ARE PRESENT. READ INSTRUCTIONS CAREFULLY BEFORE STARTING INSTALLATION. ASSISTANCE IS RECOMMENDED. THANK YOU FOR CHOOSING OUR PRODUCT!

***ROCKER PANEL MOUNT**

***DRILLING IS REQUIRED/ NO TRIMMING REQUIRED**

Torque Value

Fastener Size	Tightening Torque (ft-lbs)	Required
6mm	6-7	√
8mm	16-18	√
10mm	31-32	X
12mm	56-58	X
14mm	92-94	X

PART LIST

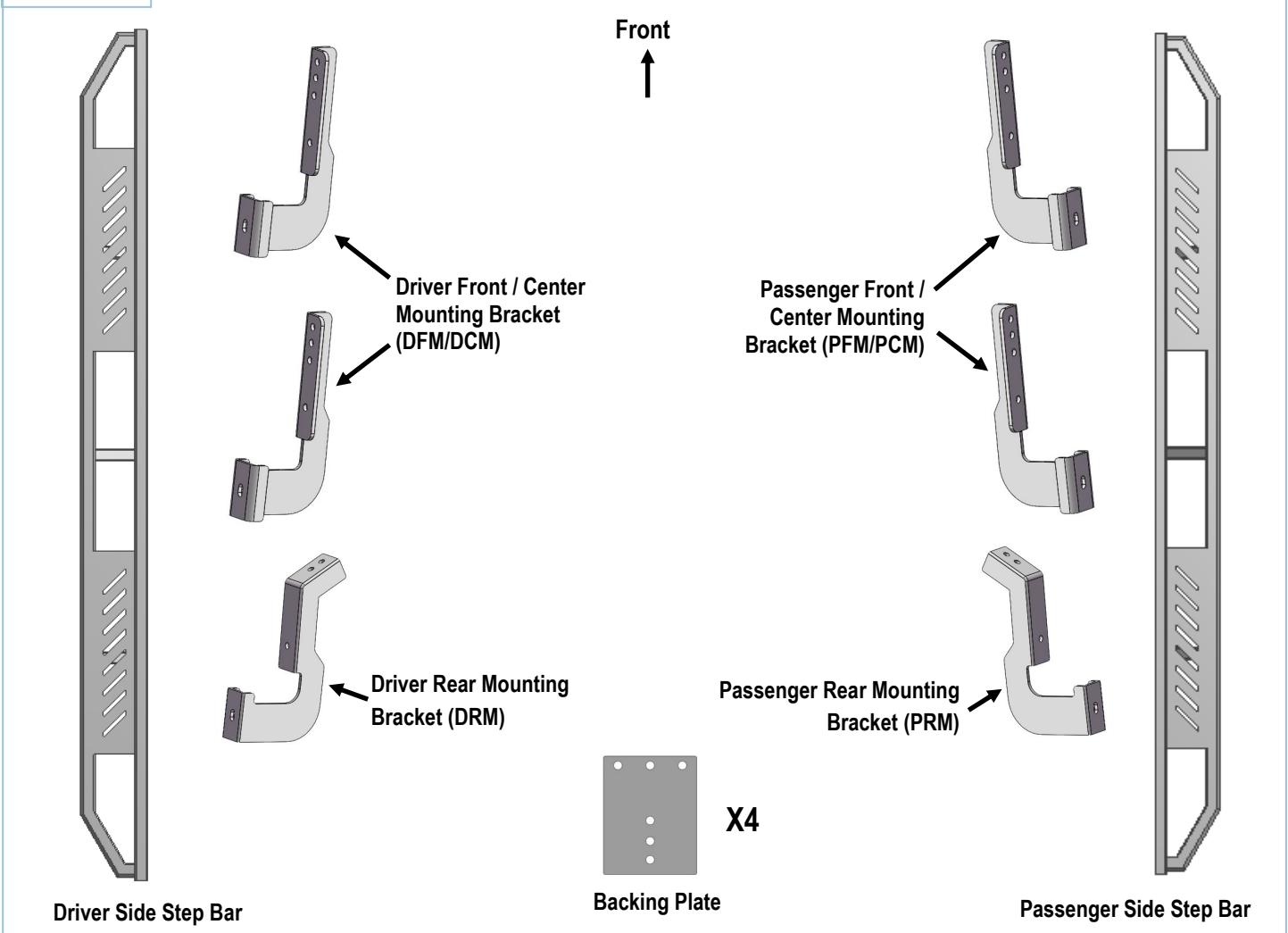

Customer Support: info@iarmorauto.com

iArmor®



The instruction here is for your reference only. We strongly recommend the professional installer for best result. We are not responsible for any damage caused by the installation.

STEP 1

Start installing from the passenger side of the vehicle. Drill (3) 5/16" holes on the pinch weld and the body panel as shown (Both sides), (Fig 1).

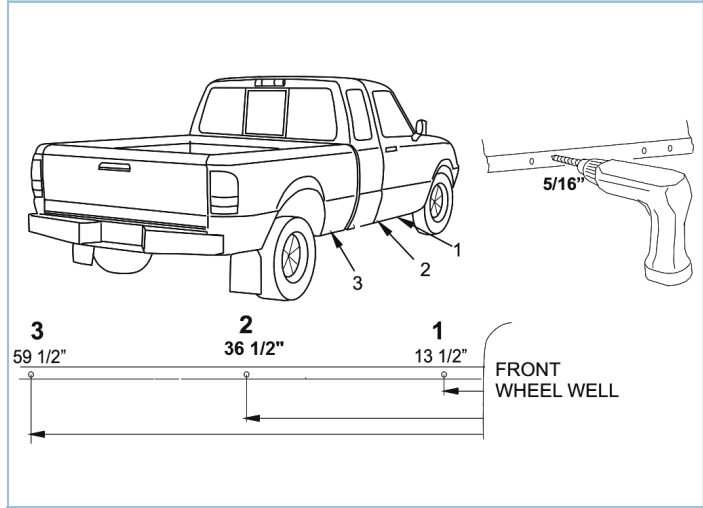

(Fig 1) Passenger Side Mounting Locations

STEP 2

Attach Passenger Front Mounting Bracket (PFM/PCM) with Backing Plate to body panel with (2) ST6.3x22mm Hex Self Tapping Screws, and to pinch weld with (1) M8X1.25-20mm Hex Bolt, (2) M8 Large Flat Washers, (1) M8 Lock Washer and (1) M8 Hex Nut, (Fig 2). Do not fully tighten hardware at this time.

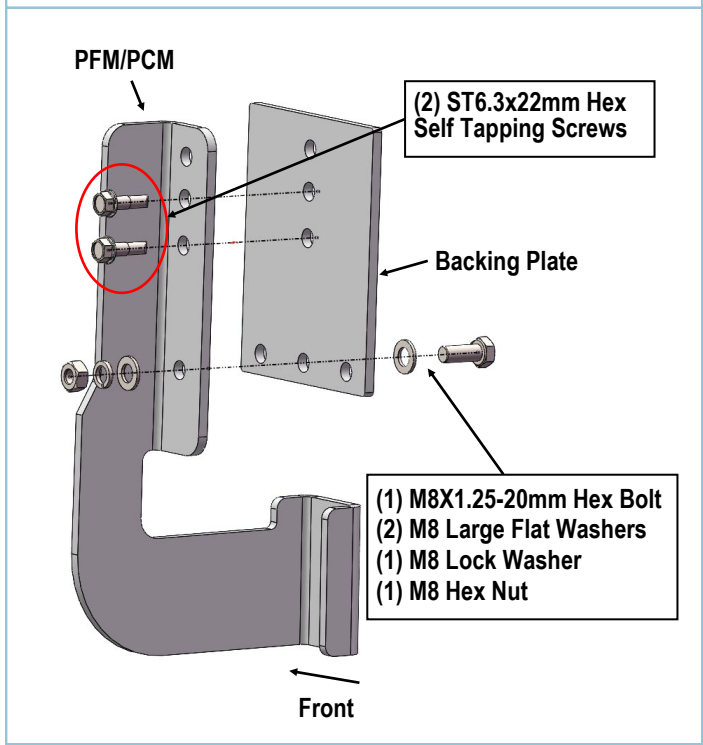

(Fig 2) Passenger Front Mounting Bracket Installed

iArmor[®]

STEP 3

Repeat **Step 2** to install the Passenger Center Mounting Bracket. **Note:** Passenger Front Mounting Bracket and Passenger Center Mounting Bracket are universal.

STEP 4

Attach Passenger Rear Mounting Bracket (**PRM**) to body panel with (2) ST6.3x22mm Hex Self Tapping Screws, and to pinch weld with (1) M8X1.25-20mm Hex Bolt, (2) M8 Large Flat Washers, (1) M8 Lock Washer and (1) M8 Hex Nut, (**Fig 3**). Do not fully tighten hardware at this time.

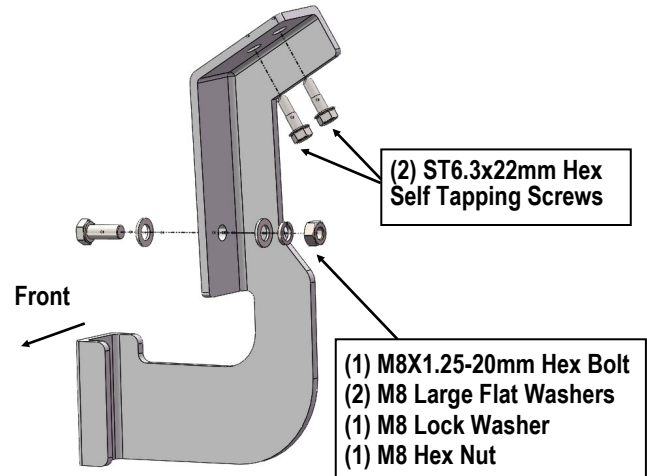

(Fig 3) Passenger Rear Mounting Bracket Installed

STEP 5

Once all (3) passenger side mounting brackets are installed, select and attach the Passenger Side Step Bar onto the Mounting Brackets with (3) U Brackets, (6) Spacers, (3) M8X1.25-55mm Carriage Bolts, (3) M8 Large Flat Washers, (3) M8 Lock Washers and (3) M8 Hex Nuts, (**Fig 4**). Do not fully tighten hardware at this time.

NOTE: Torque all M8 X1.25-55mm Carriage Bolts to 16~18 lb-ft. Don't over tighten, or the aluminum square bars will be damaged by the brackets

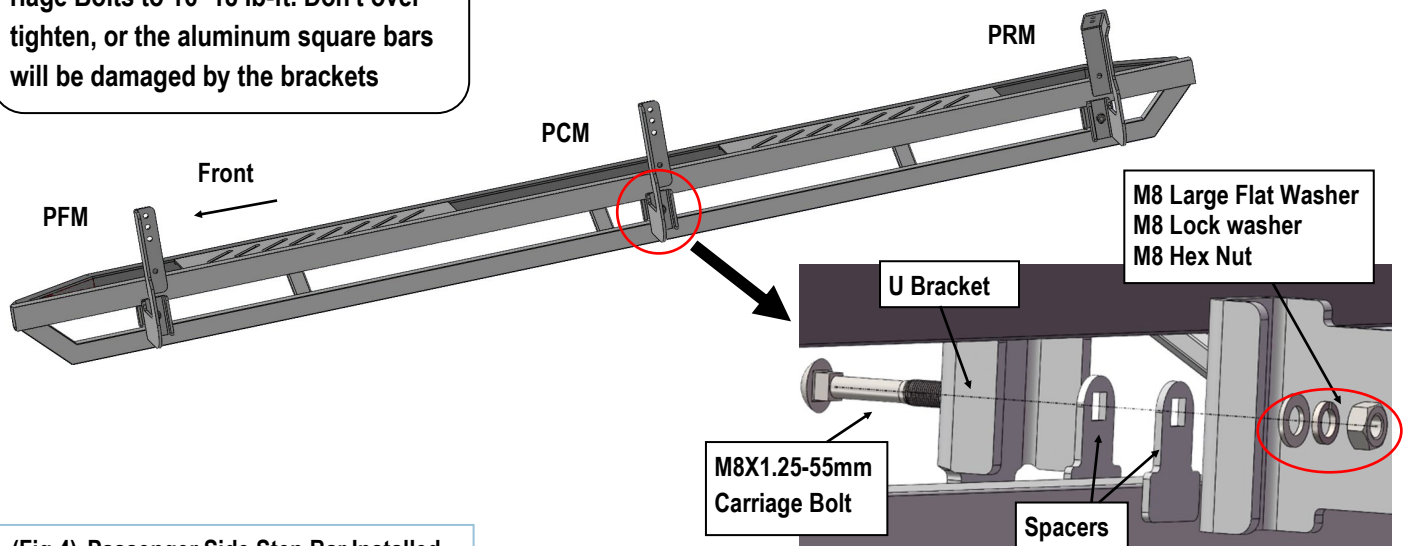

(Fig 4) Passenger Side Step Bar Installed

iArmor®

STEP 6

Properly level and adjust the Step Bar and fully tighten all hardware.

STEP 7

Move to the driver side of the vehicle. Repeat **Steps 1-6** to install driver side step bar.

Installation completed.

Attention

Do periodic inspections to the installation to make sure that all hardware is secure and tight.

In order to protect your bars/boards, please use only mild soap/non-abrasive products for cleaning.