

# iArmor<sup>®</sup>

## iArmor<sup>®</sup> by APS

PART#: IA-S925

### BEFORE INSTALLATION

REMOVE CONTENTS FROM BOX. VERIFY ALL PARTS ARE PRESENT. READ INSTRUCTIONS CAREFULLY BEFORE STARTING INSTALLATION. ASSISTANCE IS RECOMMENDED. THANK YOU FOR CHOOSING OUR PRODUCT!

\*ROCKER PANEL MOUNT

\*NO DRILLING /TRIMMING REQUIRED

Fastener Size	Tightening Torque (ft-lbs)	Required
6mm	6-7	X
8mm	16-18	√
10mm	31-32	X
12mm	56-58	X
14mm	92-94	X

Driver

Front

Passenger

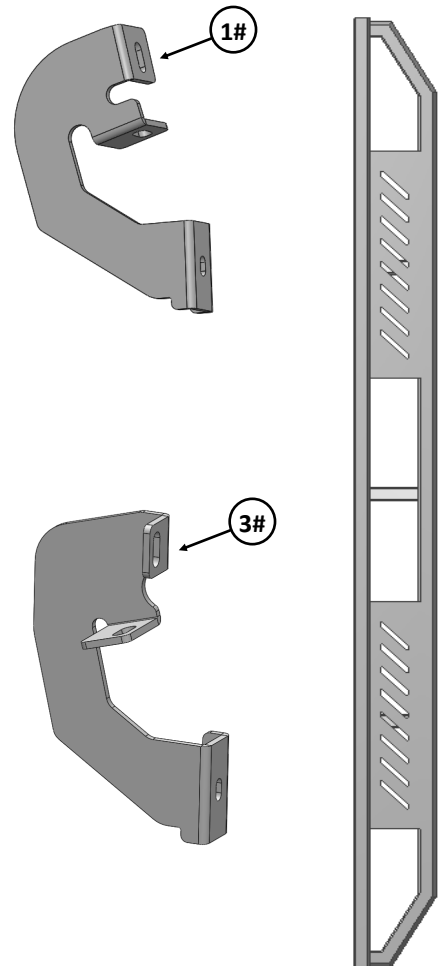
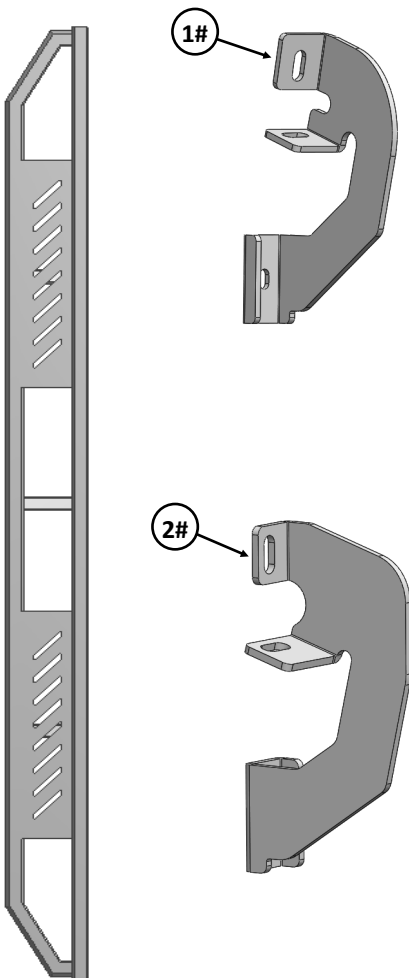

Customer Support: [info@iarmorauto.com](mailto:info@iarmorauto.com)

# iArmor®

Item	QTY	Description	Item	QTY	Description
1#	2	Driver / Passenger Front Mounting Brackets	7#	16	M8 Large Flat Washers
2#	1	Driver Rear Mounting Bracket	8#	12	M8 Lock Washers
3#	1	Passenger Rear Mounting Bracket	9#	8	M8X1.25 Hex Nuts
4#	4	U Brackets	10#	4	ST8X25mm Hex Self Tapping Screws
5#	8	Spacers	11#	4	M8X1.25-55mm Carriage Bolts
6#	8	M8X1.25-25mm Hex Bolts			

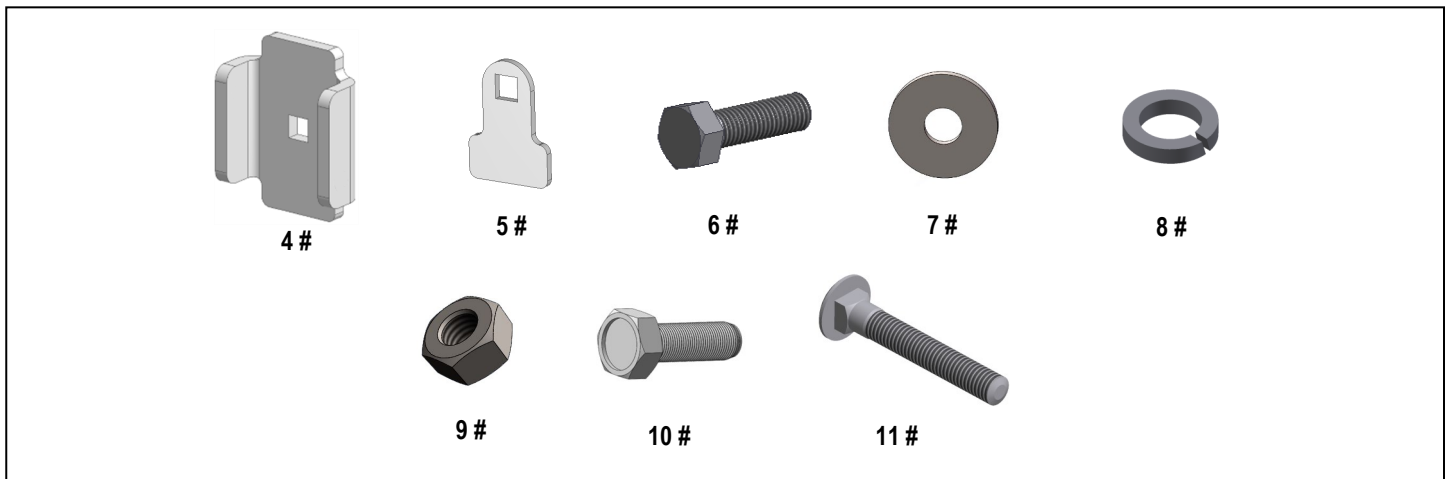

# iArmor®

The instruction here is for your reference only. We strongly recommend the professional installer for best result. We are not responsible for any damage caused by the installation.

## STEP 1

Start the installation from Passenger Side of the vehicle. Identify the mounting locations along the inner side of the rocker panel, (Fig 1). Remove any tape on the inside of rocker panel that covers the mounting holes.

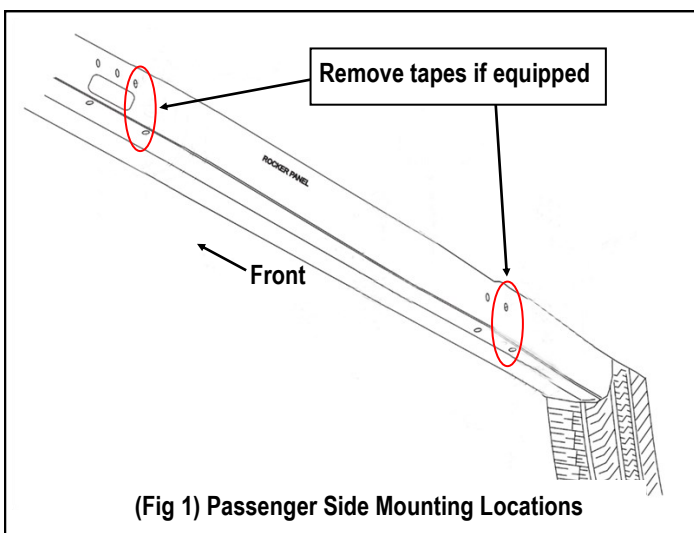

(Fig 1) Passenger Side Mounting Locations

## STEP 2

Attach (1) Passenger Front Mounting Bracket and (1) Passenger Rear Mounting Brackets the passenger side mounting locations as shown, (Figs 2&3).

**NOTE:** (1) ST8X25mm Hex Self Tapping Screw replace (1) M8X1.25-25mm Hex Bolt per bracket if the factory holes are not tapped for M8x1.25-25mm Hex Bolts.

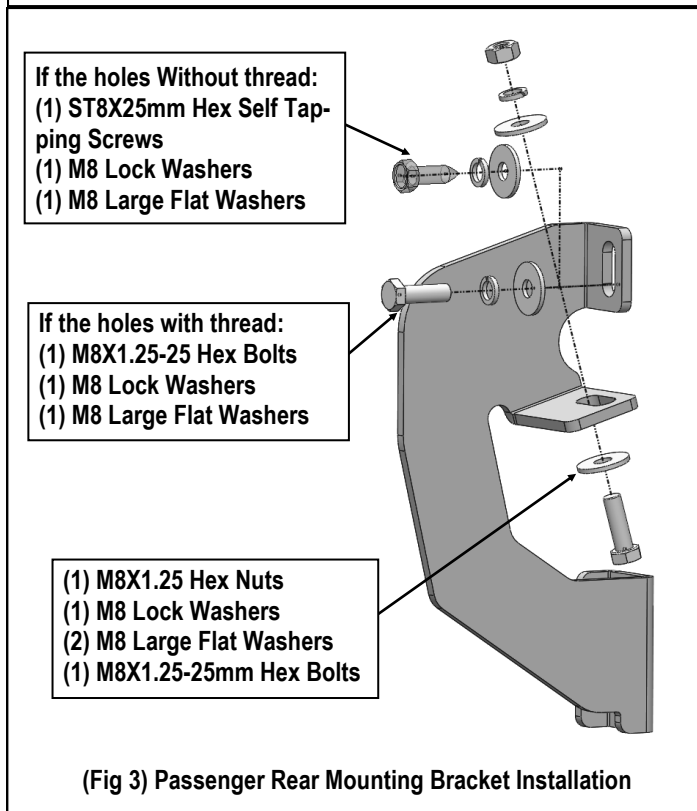
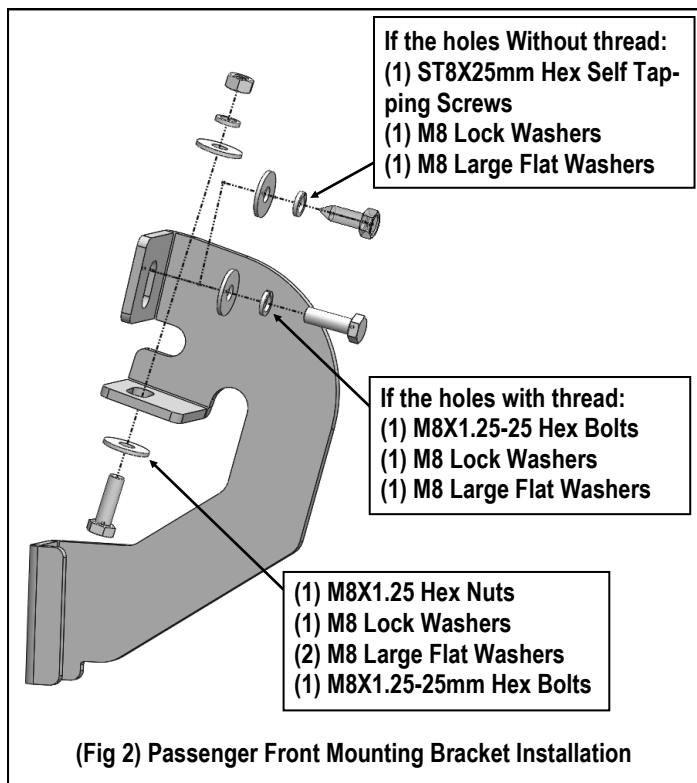

# iArmor®

## STEP 3

Once all (2) passenger side mounting brackets are installed, select and attach the Passenger Side Step Bar onto the Mounting Brackets with (2) U Brackets, (4) Spacers, (2) M8X1.25-55mm Carriage Bolts, (2) M8 Large Flat Washers, (2) M8 Lock Washers and (2) M8X1.25 Hex Nuts, (Fig 4). Do not fully tighten hardware at this time.

## STEP 4

Properly level and adjust the Step Bar and fully tighten all hardware.

## STEP 5

Move to the driver side of the vehicle. Repeat **Steps 1-4** to install the driver side step bar.

Installation completed.

### Attention

Do periodic inspections to the installation to make sure that all hardware is secure and tight.

In order to protect your bars/boards, please use mild soap/non-abrasive products for cleaning only.

**NOTE:** Torque all M8 X1.25-55mm Carriage Bolts to 16~18 lb-ft. Don't over tighten, or the aluminum square bars will be damaged by the brackets

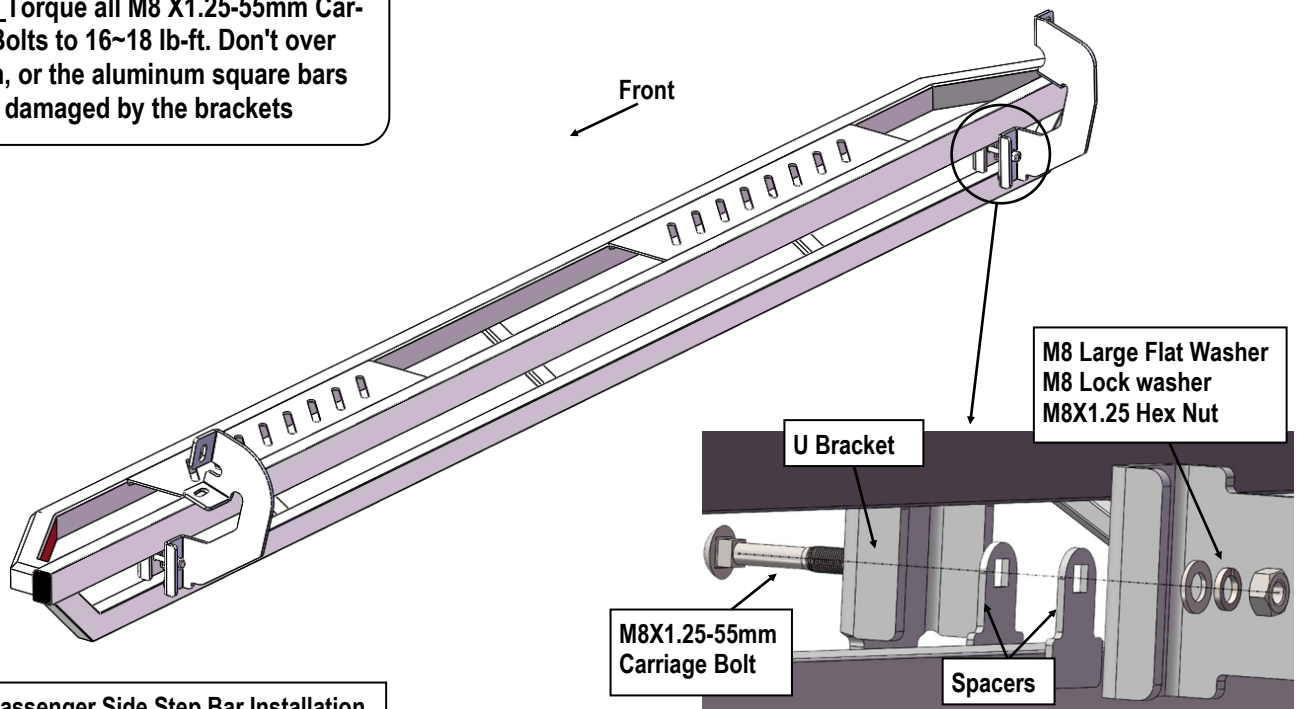

(Fig 4) Passenger Side Step Bar Installation