

iArmor[®]

iArmor[®] by APS

PART#: IA-S177

BEFORE INSTALLATION

REMOVE CONTENTS FROM BOX. VERIFY ALL PARTS ARE PRESENT. READ INSTRUCTIONS CAREFULLY BEFORE STARTING INSTALLATION. ASSISTANCE IS RECOMMENDED. THANK YOU FOR CHOOSING OUR PRODUCT!

*ROCKER PANEL MOUNT

*DRILLING IS REQUIRED/ NO TRIMMING REQUIRED

Fastener Size	Tightening Torque (ft-lbs)	Required
6mm	6-7	X
8mm	16-18	√
10mm	31-32	√
12mm	56-58	X
14mm	92-94	X

Driver

Front

Passenger

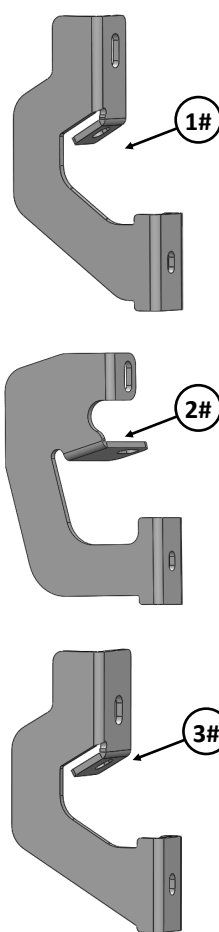
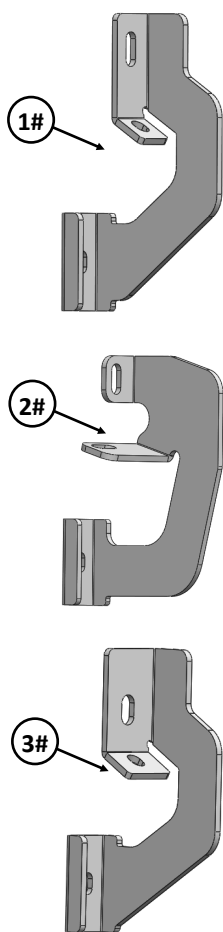

iArmor[®]

Item	QTY	Description	Item	QTY	Description
1#	2	Driver & Passenger Front Mounting Brackets	9#	2	M10X1.5 Hex Nuts
2#	2	Driver & Passenger Center Mounting Brackets	10#	10	M8X1.25-25mm Hex Bolts
3#	2	Driver & Passenger Rear Mounting Brackets	11#	22	M8 Large Flat Washers
4#	6	U Brackets	12#	16	M8 Lock Washers
5#	12	Spacers	13#	4	M8 Clip Nuts
6#	2	M10X45mm Bolt Plates	14#	12	M8X1.25 Hex Nuts
7#	2	M10 Large Flat Washers	15#	6	M8X1.25-55mm Carriage Bolts
8#	2	M10 Lock Washers			

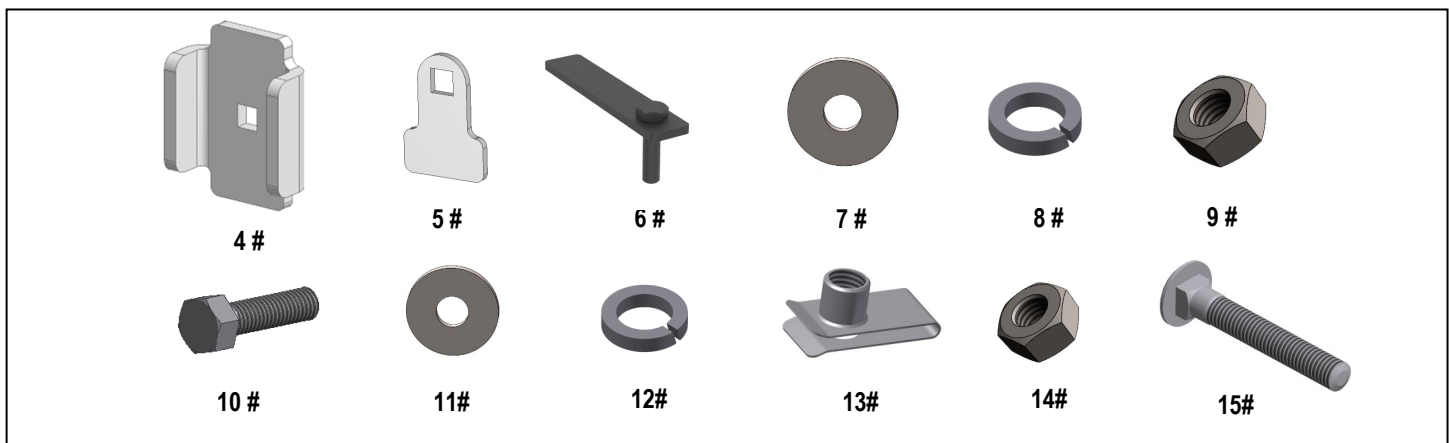

iArmor[®]

The instruction here is for your reference only. We strongly recommend the professional installer for best result. We are not responsible for any damage caused by the installation.

STEP 1

Identify the passenger side mounting locations as shown, (Fig 1).

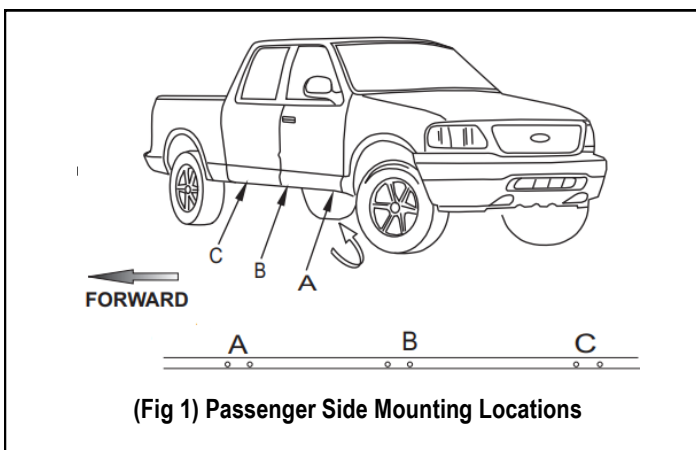

STEP 2

Install M8 Clip Nuts as shown, (Figs 2-3).

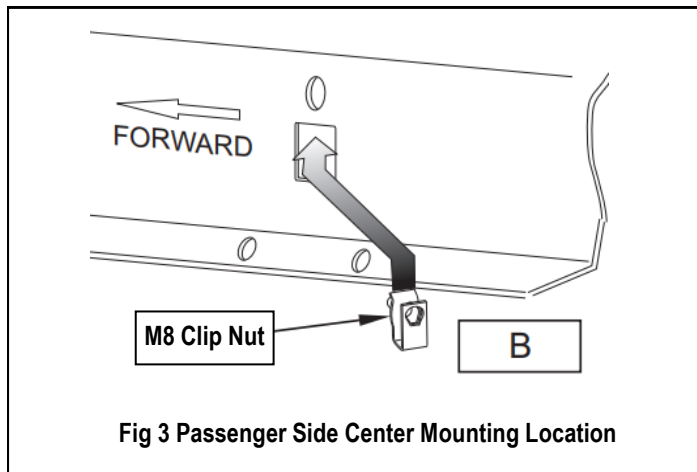
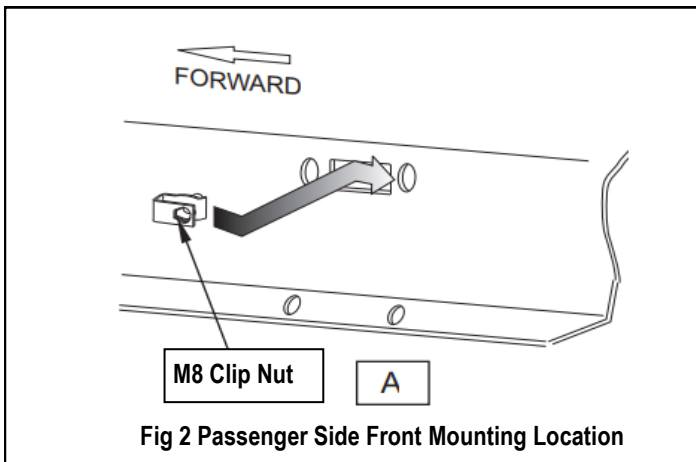

STEP 3

Attach the Passenger Front Bracket and Passenger Center Bracket to the rocker panel as shown (Figs 4 & 5). Don't fully tighten at this time.

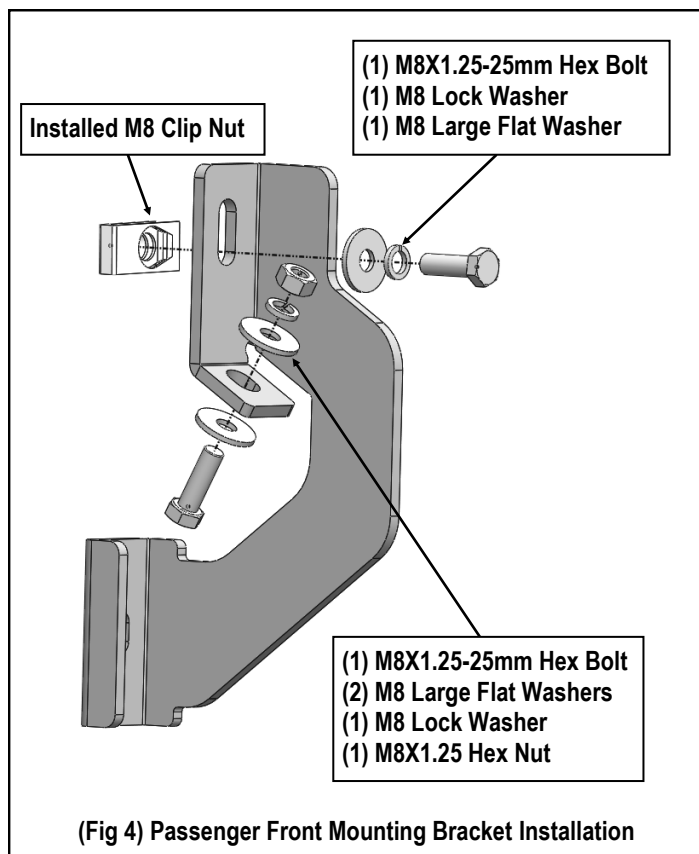

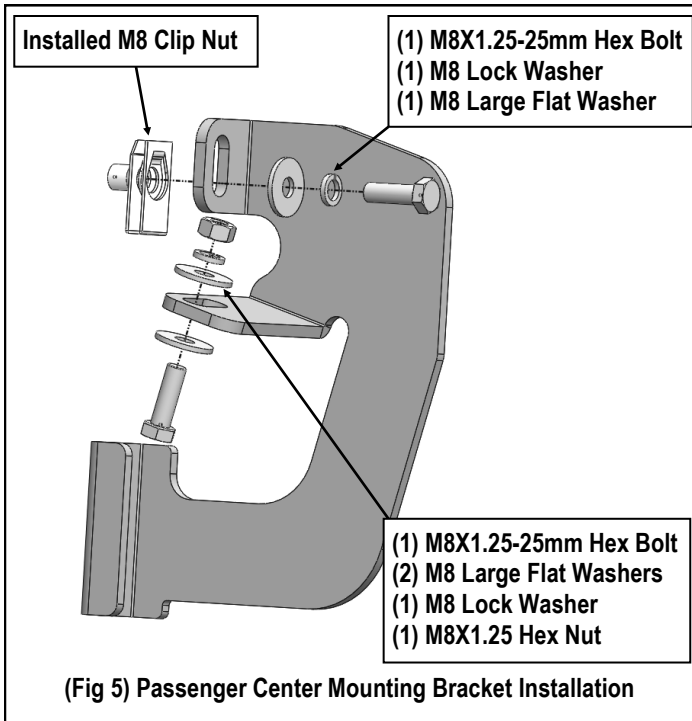

STEP 4

Attach the Passenger Rear Mounting Bracket by locating the large circular hole on the rocker panel insert (1) M10X45mm Bolt Plate into the hole and attach the rear bracket with (1) M10 Large Flat Washer, (1) M10 Lock Washer, and (1) M10X1.5 Hex Nut. Don't fully tighten at this time, (Fig 6).

Once attached, drill a 8mm hole through the pinch weld and install lower hole of the bracket with (1) M8X1.25-25mm Hex Bolts, (2) M8 Large Flat Washers, (1) M8 Lock Washers, (1) M8X1.25 Hex Nuts. Don't fully tighten at this time, (Fig 6).

STEP 5

Once all (3) passenger side mounting brackets are installed, select and attach the Passenger Side Step Bar onto the Mounting Brackets with (3) U Brackets, (6) Spacers, (3) M8X1.25-55mm Carriage Bolts, (3) M8 Large Flat Washers, (3) M8 Lock Washers and (3) M8X1.25 Hex Nuts. Do not fully tighten hardware at this time, (Fig 7).

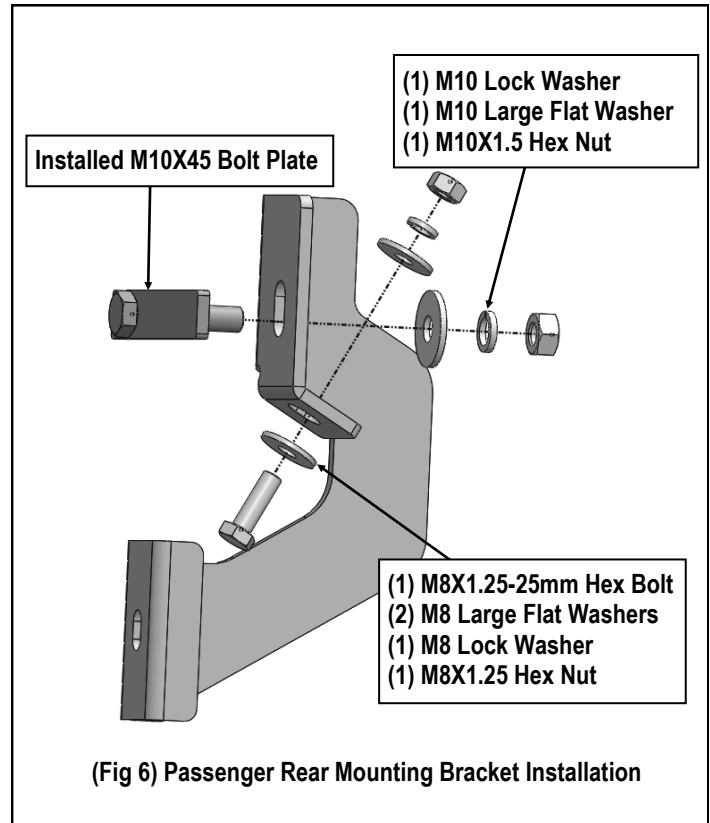

STEP 6

Properly level and adjust the Step Bar and fully tighten all hardware.

STEP 7

Move to the driver side of the vehicle. Repeat **Steps 1-6** to install the driver side step bar.

Installation completed.

Attention

Do periodic inspections to the installation to make sure that all hardware is secure and tight.

In order to protect your bars/boards, please use mild soap/non-abrasive products for cleaning only.

iArmor®

NOTE: Torque all M8 X1.25-55mm Carriage Bolts to 16~18 lb-ft. Don't over tighten, or the aluminum square bars will be damaged by the brackets

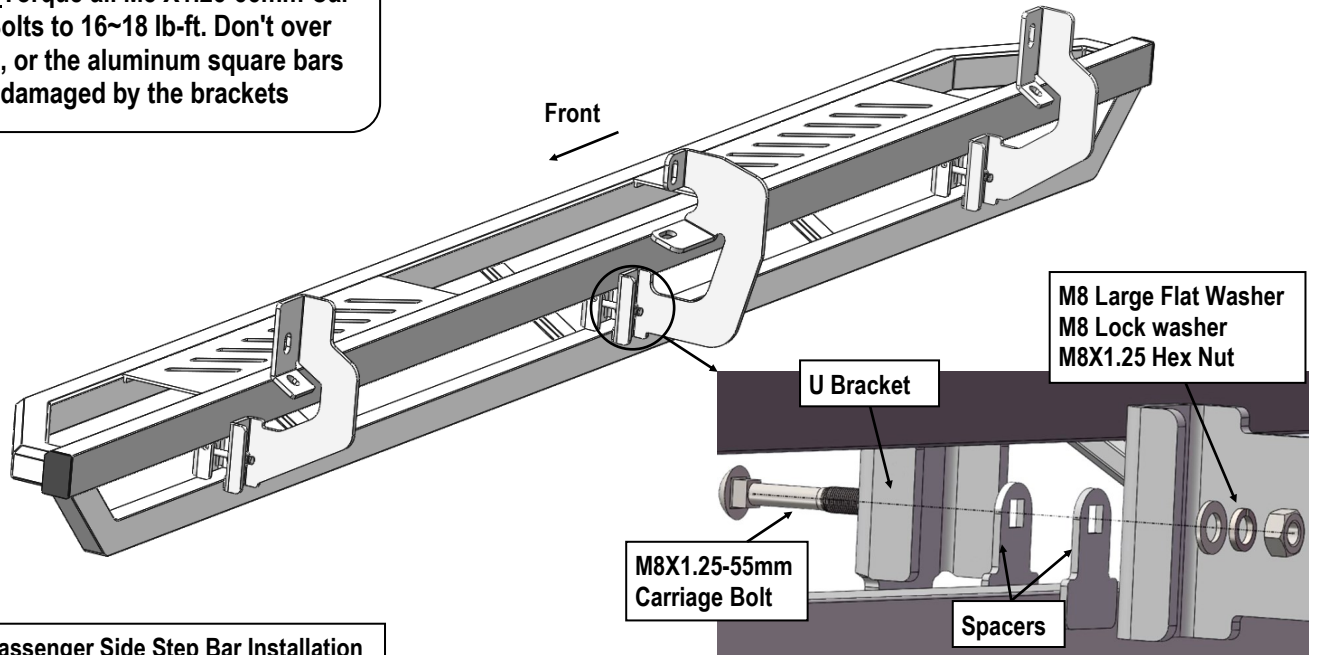

(Fig 7) Passenger Side Step Bar Installation