

iArmor[®]

iArmor[®] by APS

PART#: IA-S176

BEFORE INSTALLATION

REMOVE CONTENTS FROM BOX. VERIFY ALL PARTS ARE PRESENT. READ INSTRUCTIONS CAREFULLY BEFORE STARTING INSTALLATION. ASSISTANCE IS RECOMMENDED. THANK YOU FOR CHOOSING OUR PRODUCT!

***ROCKER PANEL MOUNT**

***NO DRILLING / TRIMMING REQUIRED**

Torque Value

Fastener Size	Tightening Torque (ft-lbs)	Required
6mm	6-7	X
8mm	16-18	√
10mm	31-32	√
12mm	56-58	X
14mm	92-94	X

PART LIST

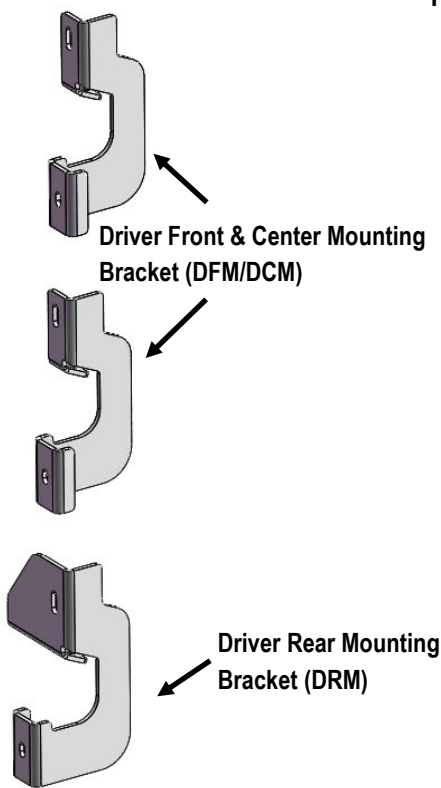

Front
↑

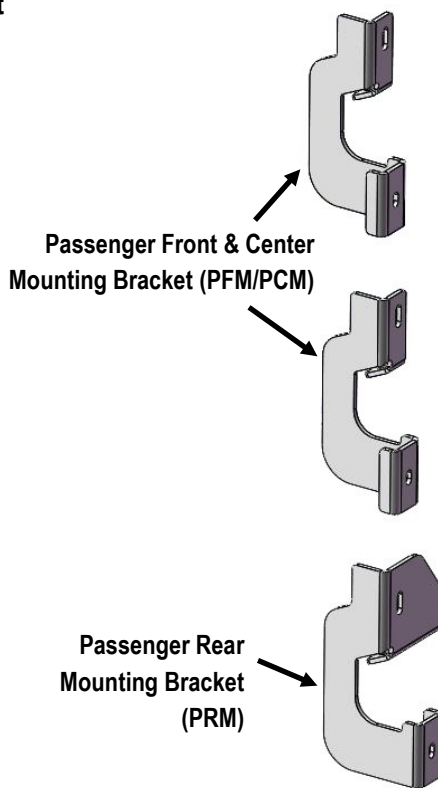

*Driver Front Mounting Bracket and Driver Center Mounting Bracket are Universal.

*Passenger Front Mounting Bracket and Passenger Center Mounting Bracket are Universal.

Customer Support: info@iarmorauto.com

iArmor®

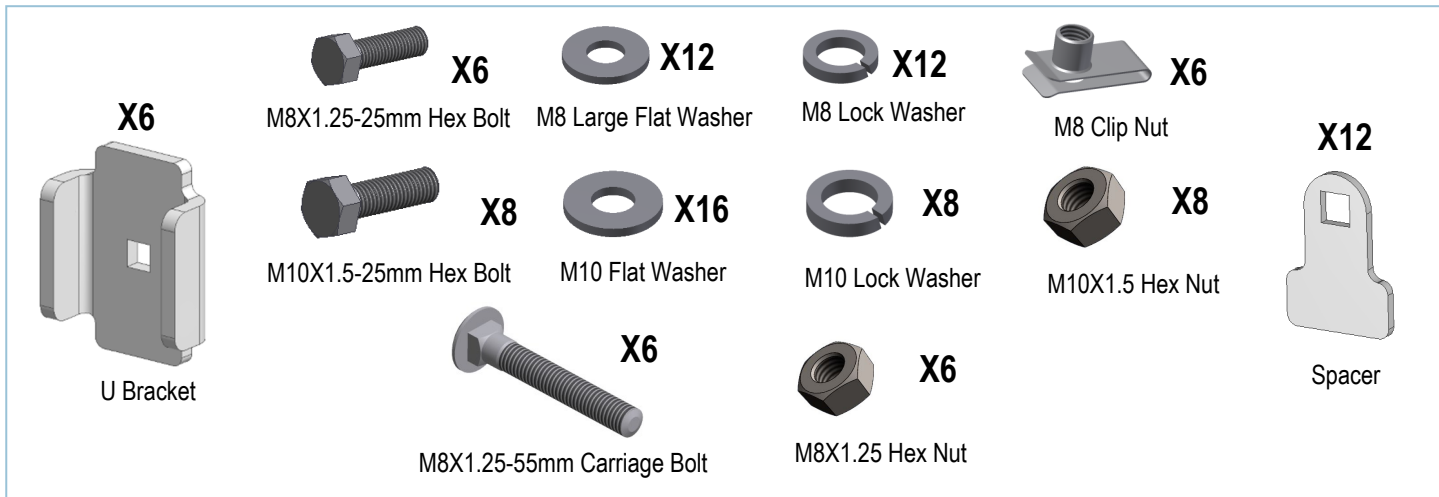

The instruction here is for your reference only. We strongly recommend the professional installer for best result. We are not responsible for any damage caused by the installation.

STEP 1

Locate Passenger Side mounting locations on pinch weld as shown on (See Fig 1).

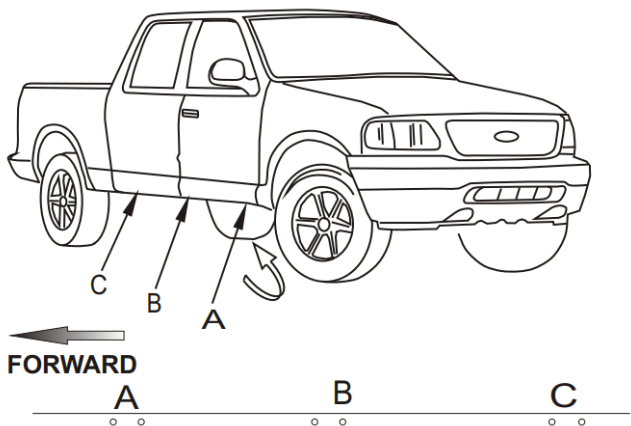

(Fig 1) Passenger Side Mounting Locations Pictured

STEP 2

Install M8 Clip Nuts into the holes on the body pane as shown (Fig 2).

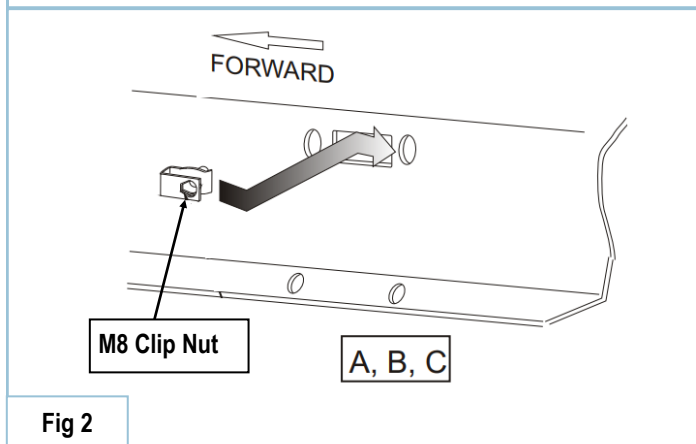

Fig 2

STEP 3

Start the installation from Passenger front mounting location. Attach Passenger Front Mounting Bracket with (1) M8X1.25-25mm Hex Bolt, (1) M8 Large Flat Washer, (1) M8 Lock Washer and (1) M10X1.5-25mm Hex Bolt, (2) M10 Flat Washers, (1) M10 Lock Washer, (1) M10X1.5 Hex Nut. Finger tightens (Fig 3).

Repeat to install Passenger Center Mounting Bracket.

iArmor®

STEP 4

Move to Driver Side Rear Mounting Location . Attach Passenger Rear Mounting Bracket as shown. Leave brackets loose at this time.

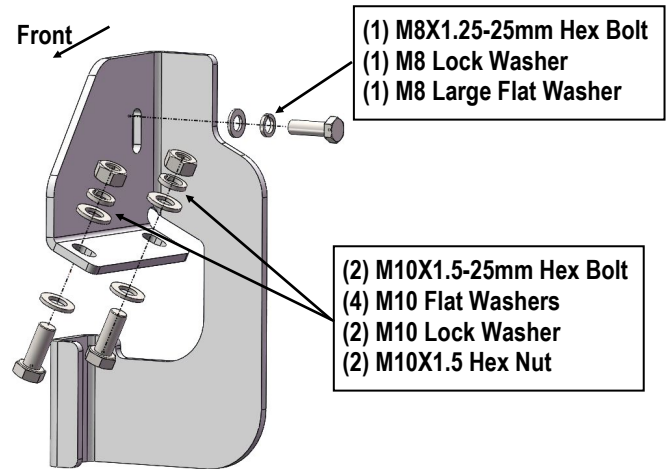

(Fig 4) Passenger Rear Mounting Bracket Installation

STEP 5

Once all (3) passenger side mounting brackets are installed, select and attach the Passenger Side Step Bar onto the Mounting Brackets with (3) U Brackets, (6) Spacers, (3) M8X1.25-55mm Carriage Bolts, (3) M8 Large Flat Washers, (3) M8 Lock Washers and (3) M8X1.25 Hex Nuts (Fig 5). Do not fully tighten hardware at this time.

NOTE: Torque all M8 X1.25-55mm Carriage Bolts to 16~18 lb-ft. Don't over tighten, or the aluminum square bars will be damaged by the brackets

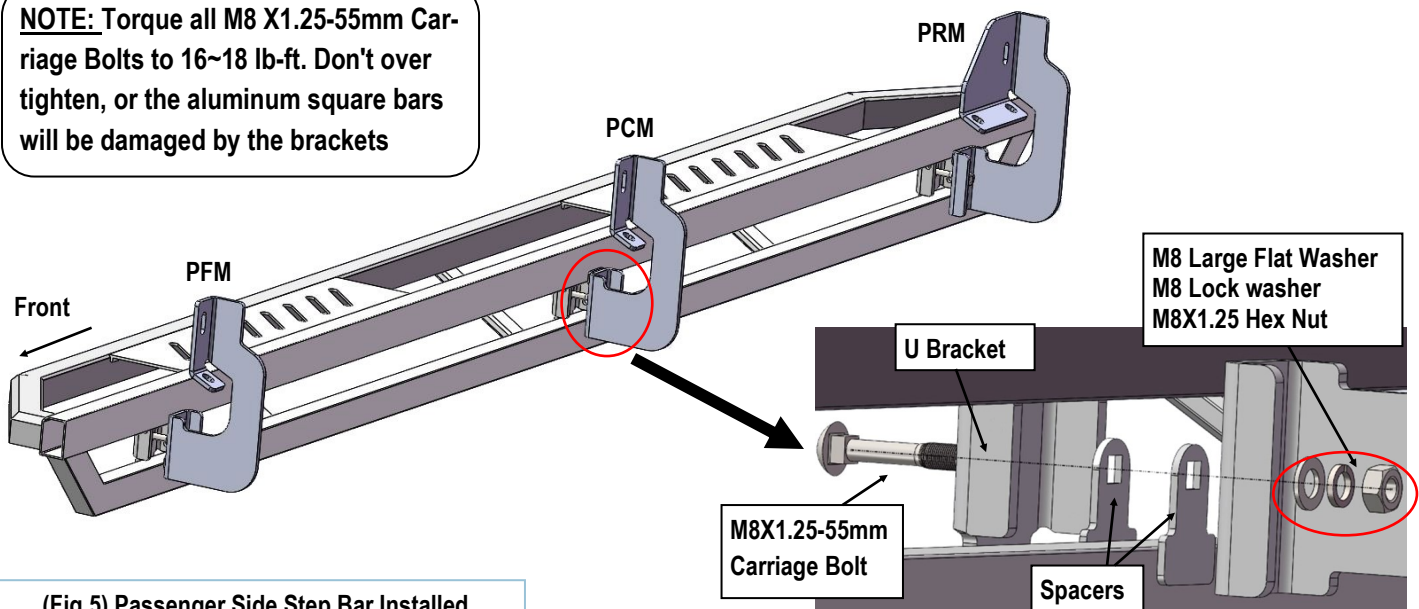

(Fig 5) Passenger Side Step Bar Installed

iArmor[®]

STEP 6

Properly level and adjust the Step Bar and fully tighten all hardware.

STEP 7

Move to the driver side of the vehicle. Repeat **Steps 1-6** to install driver side step bar.

Installation completed.

Attention

Do periodic inspections to the installation to make sure that all hardware is secure and tight.

In order to protect your bars/boards, please use only mild soap/non-abrasive products for cleaning.