

IARMOR EDGE™

PART#: IA-N042

BEFORE INSTALLATION

REMOVE CONTENTS FROM BOX. VERIFY ALL PARTS ARE PRESENT. READ INSTRUCTIONS CAREFULLY BEFORE STARTING INSTALLATION. ASSISTANCE IS RECOMMENDED. THANK YOU FOR CHOOSING OUR PRODUCT!

*DRILLING NOT REQUIRED

*TRIMMING NOT REQUIRED

Fastener Size	Tightening Torque (ft-lbs)	Required
6mm	6-7	√
8mm	16-18	√
10mm	31-32	√
12mm	56-58	X
14mm	92-94	X

Item	QTY	Description	Item	QTY	Description
1#	4	Mounting Brackets	7#	8	M10 Flat Washers
2#	4	M8X1.25-25mm Hex Bolts	8#	4	M10 Lock Washers
3#	4	M8 Flat Washers	9#	4	M10 Hex Nuts
4#	4	M8 Lock Washers	10#	24	M6X1-20mm T-Bolts
5#	4	M8 Clip Nuts	11#	24	M6 Large Flat Washers
6#	4	M10X1.5-25mm Hex Bolts	12#	24	M6 Nylon Lock Nuts

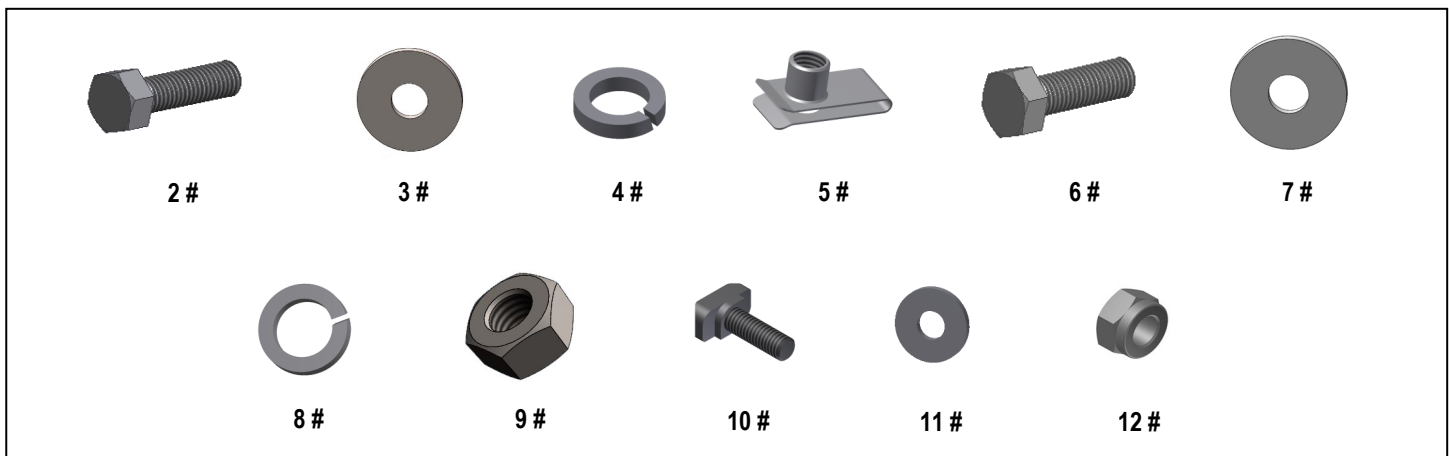

iArmor[®]

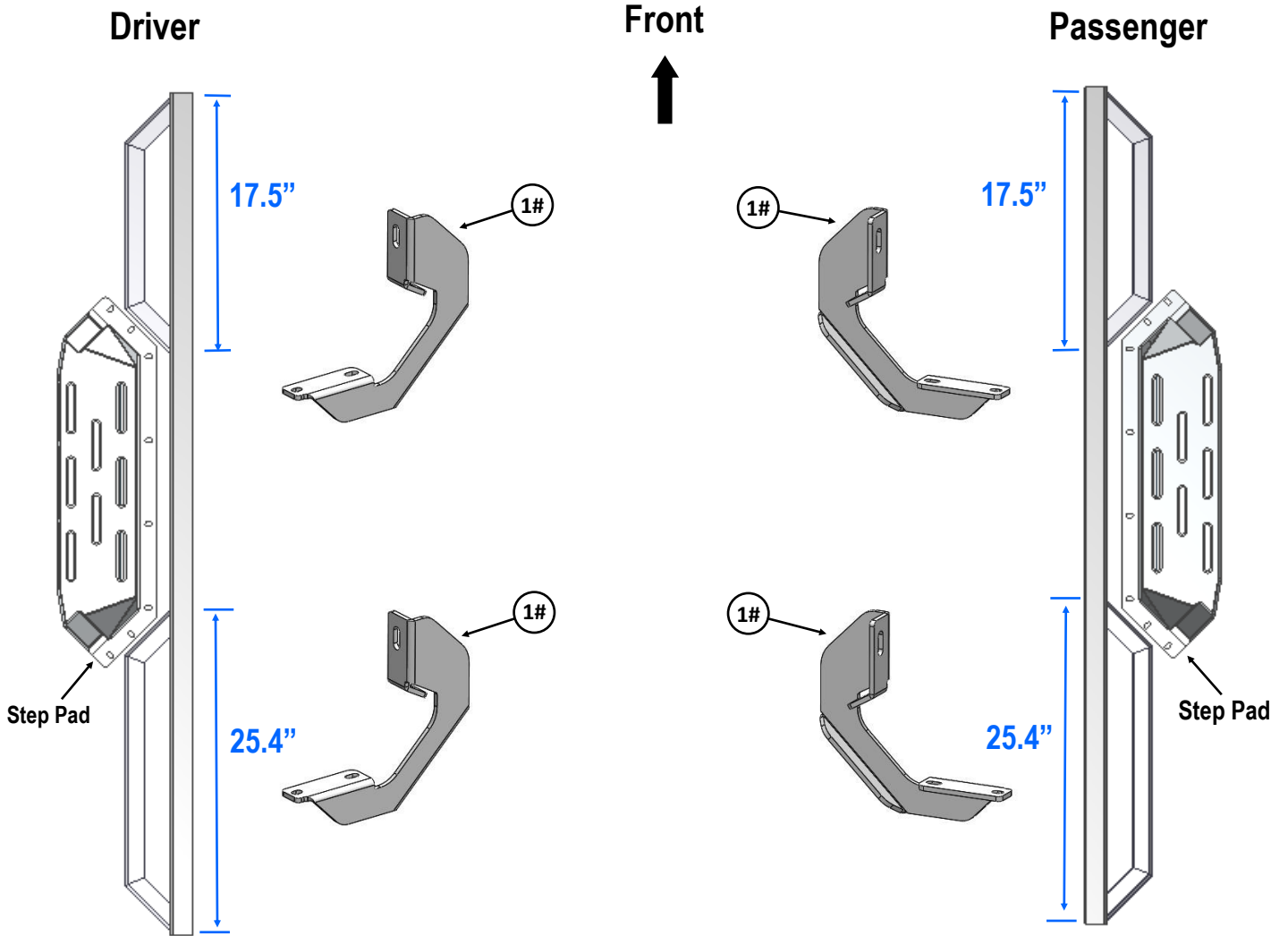

iArmor[®]

The instruction here is for your reference only. We strongly recommend the professional installer for best result. We are not responsible for any damage caused by the installation.

STEP 1

Install the Step Pads onto the step bars with (16) M6x1-20mm T-Bolts, (16) M6 Flat Washers and (16) M6 Nylon Lock Nuts.

IMPORTANT: Don't hit the step pad by any metal hammer within step pad installation, or the step pad will be damaged.

(8) M6X1-20mm T-Bolts
(8) M6 Flat Washers
(8) M6 Nylon Lock Nuts

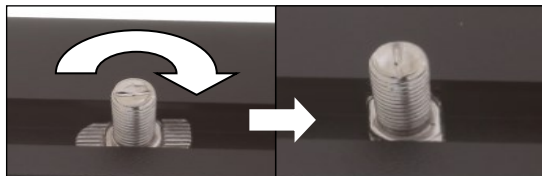

Note: Rotate 90° after inserting the T-Bolts into the Channel!!!

STEP 2

Start installation from the passenger side of the vehicle. Locate Passenger Side mounting locations as shown on **Fig 1**.

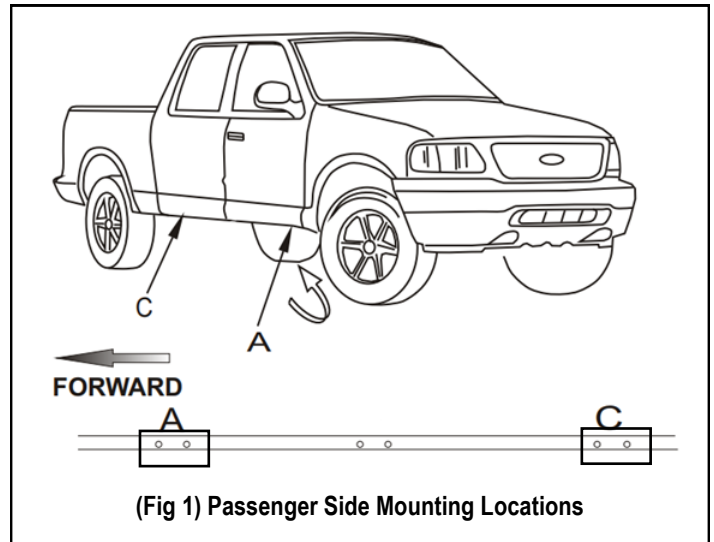

(Fig 1) Passenger Side Mounting Locations

STEP 3

Start from the passenger front mounting location. Select (1) M8 Clip Nut. Install M8 Clip Nut as shown, (**Fig 2**).

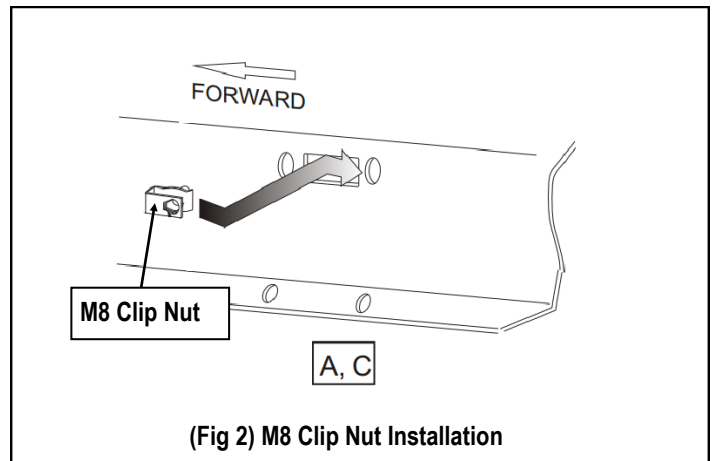

(Fig 2) M8 Clip Nut Installation

STEP 4

Attach (1) Mounting Bracket to the installed M8 Clip Nut with (1) M8X1.25-25mm Hex Bolt, (1) M8 Flat Washer, (1) M8 Lock Washer; to pinch weld with (1) M10X1.5-25mm Hex Bolt, (2) M10 Flat Washers, (1) M10 Lock Washer, (1) M10 Hex Nut, (**Fig 3**). Do not fully tighten hardware at this time.

iArmor®

- (1) M8X1.25-25mm Hex Bolt
- (1) M8 Flat Washer
- (1) M8 Lock Washer

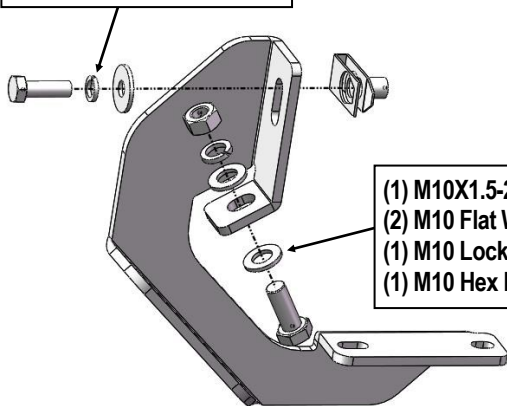

(Fig 3) Passenger Front Mounting Bracket Installed

STEP 5

Move to the passenger side rear of the vehicle. Select (1) Mounting Bracket. Repeat **Steps 1—3** to install the passenger side Rear Mounting Brackets.

STEP 6

Once (2) passenger side brackets are installed, attach the assembled Passenger Side Step Bar onto the Mounting Brackets with (4) M6X1-20mm T-Bolts, (4) M6 Flat Washers and (4) M6 Nylon Lock Nuts, (Fig 4). Do not fully tighten hardware.

STEP 7

Properly level and adjust the Step Bar and fully tighten all hardware.

STEP 8

Move to the Driver side of the vehicle. Repeat **Steps 2-7** for the Driver Side Step Bar installation.

Attention

Do periodic inspections to the installation to make sure that all hardware is secure and tight.

In order to protect your bars/boards, please use only mild soap/non-abrasive products for cleaning.

(Fig 4) Passenger Side Step Bar Installation

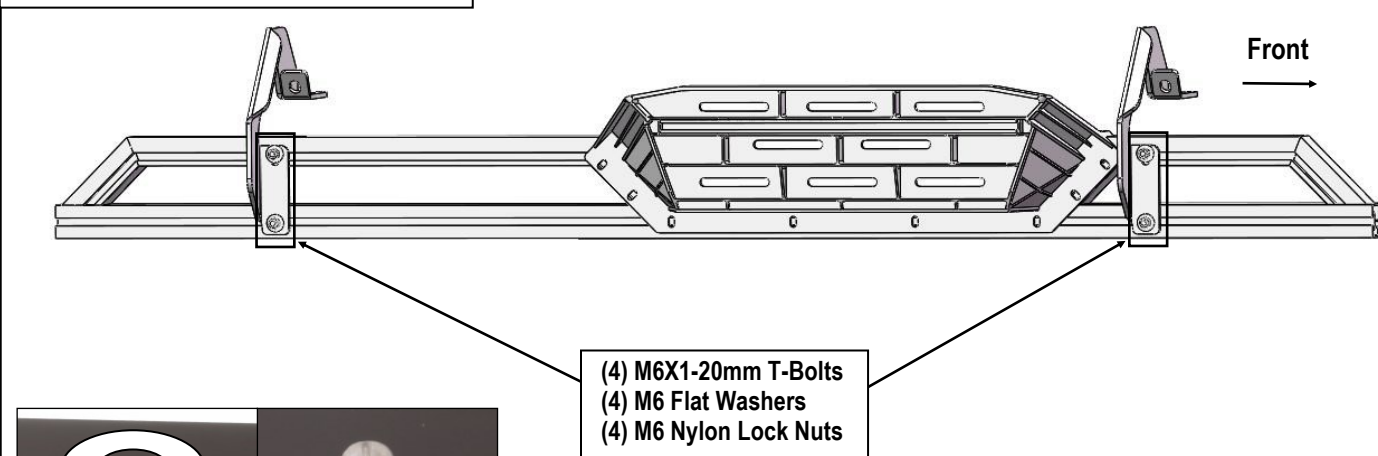

Warning: Install the T-bolt on the step bar and rotate it to 90 degrees!!!