

iArmor[®]

IARMOR EDGE™

PART#: IA-N011

BEFORE INSTALLATION

REMOVE CONTENTS FROM BOX. VERIFY ALL PARTS ARE PRESENT. READ INSTRUCTIONS CAREFULLY BEFORE STARTING INSTALLATION. ASSISTANCE IS RECOMMENDED. THANK YOU FOR CHOOSING OUR PRODUCT!

*DRILLING NOT REQUIRED

*TRIMMING NOT REQUIRED

Torque Value

Fastener Size	Tightening Torque (ft-lbs)	Required
6mm	6-7	√
8mm	16-18	√
10mm	31-32	√
12mm	56-58	X
14mm	92-94	X

PART LIST

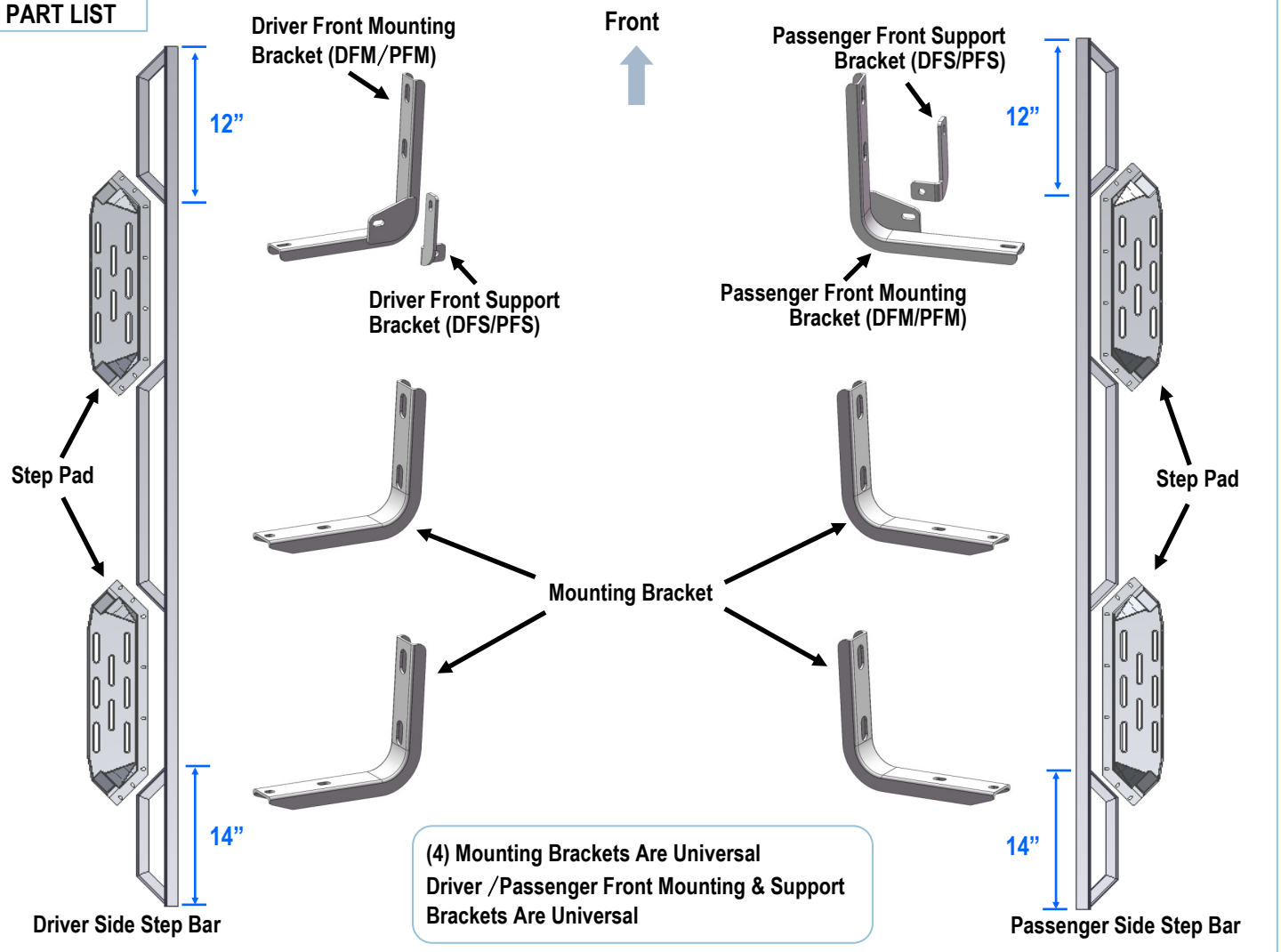

Customer Support: info@iarmorauto.com

iArmor®

 X12 M10X1.5-30 Hex Bolt	 X18 M10 Flat Washer	 X12 M10 Lock Washer	 X6 M10 Hex Nut	 X6 M10 Clip Nut	 X2 M8X1.25-30 Hex Bolt
 X4 M8 Flat Washer	 X2 M8 Nylon Lock Nut	 X4 M6X1-20 Square Head Bolt	 X40 M6X1-20 T-Bolt	 X44 M6 Large Flat Washer	 X44 M6 Nylon Lock Nut

The instruction here is for your reference only. We strongly recommend the professional installer for best result. We are not responsible for any damage caused by the installation.

STEP 1

Install the Step Pads onto the step bars with (32) M6X1-20 T-Bolts, (32) M6 Large Flat Washers and (32) M6 Nylon Lock Nuts.

IMPORTANT: Don't hit the step pad by any metal hammer within step pad installation, or the step pad will be damaged.

(8) M6X1-20 T-Bolts
(8) M6 Flat Washers
(8) M6 Nylon Lock Nuts

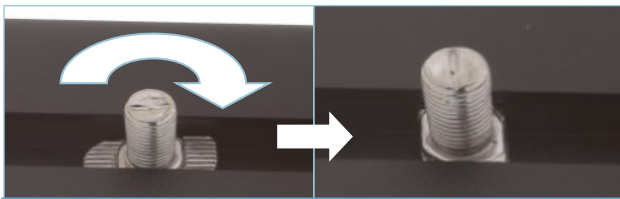

Note: Rotate 90° after inserting the T-Bolts into the Channel!!!

STEP 2

Starting installation from the passenger side of the vehicle, locate the (5) pairs of factory holes along the pinch weld. Move to the 2nd pair of holes directly under the center of the front door, (Figs 1 & 2). **NOTE:** There are (5) mounting locations along the inner body panel. Running Board installation will use the 2nd, 3rd and 5th mounting locations, (Fig 1).

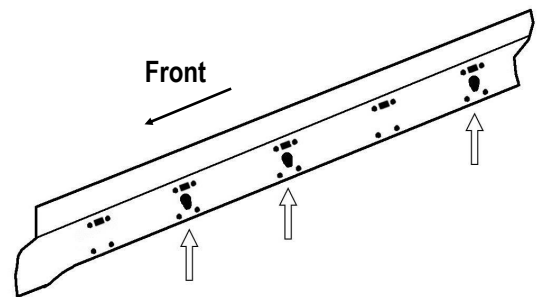

(Fig 1) Passenger Side Mounting Locations (on The inner side of the Rocker Panel)

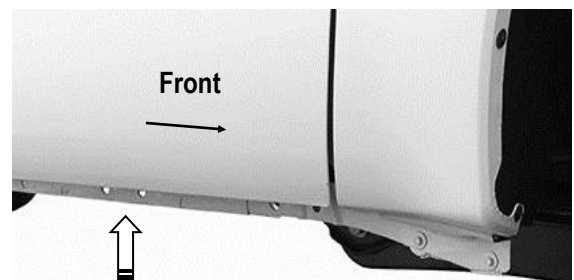

(Fig 2) Passenger Side Front Mounting Location (The 2nd Pair of Factory Holes on Pinch Weld)

iArmor®

STEP 3

Select (1) M10 Clip Nut. Insert Clip Nuts into the round hole beside the rectangular opening. **NOTE:** Threaded nut must go towards the inside of the side panel, (Figs 3 & 4).

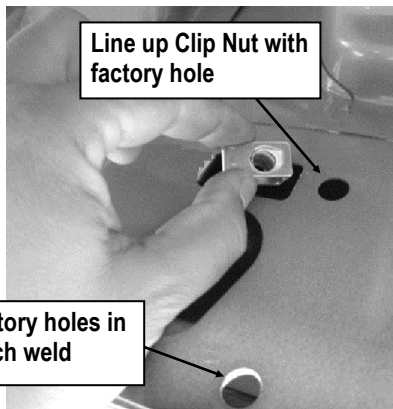

(Fig 3) Typical Mounting Location

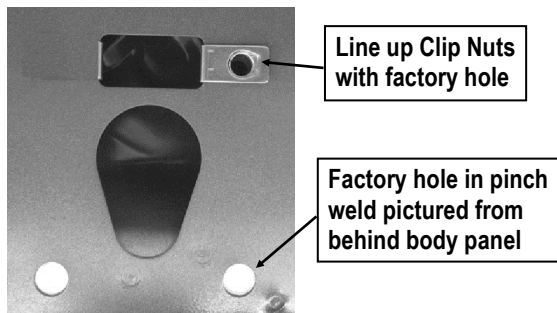

(Fig 4) M10 Clip Nut Installation

STEP 4

Assemble the Passenger Front Mounting Bracket (DFM/PFM) and Passenger Front Support Bracket (DFS/PFS) with (1) M8X1.25-30 Hex Bolt, (2) M8 Flat Washers and (1) M8 Nylon Lock Nut, (Fig 5). Do not fully tighten hardware at this time.

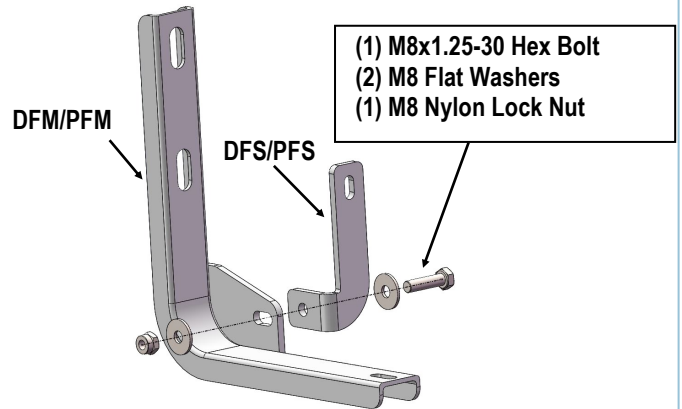

(Fig 5) Passenger Front Mounting Bracket Assembly

STEP 5

Attach the Assembled Passenger Front Bracket to the Clip Nut with the included (1) M10X1.5-30 Hex Bolt, (1) M10 Lock Washer and (1) M10 Flat Washer, (Fig 6). Attach the bottom hole in the Mounting Bracket to the (1) hole in the pinch weld with the included (1) M10X1.5-30 Hex Bolt, (2) M10 Flat Washers, (1) M10 Lock Washer and (1) M10 Hex Nut, (Fig 6). Do not fully tighten hardware at this time.

NOTE: Insert the Hex Bolt with Flat Washer through pinch weld first then through the Bracket from outside to inside.

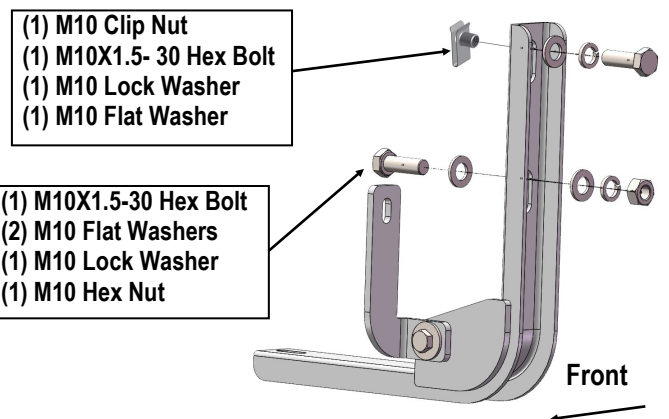

(Fig 6) Passenger Front Bracket Installation

iArmor®

STEP 6

Move to the Passenger Side Center Mounting location, (Fig 7). Repeat **Steps 3 & 5** to install the Passenger Center Mounting Bracket, (Fig 8). **Note: Passenger Center/Rear and Driver Center/ Rear Mounting Brackets are universal.**

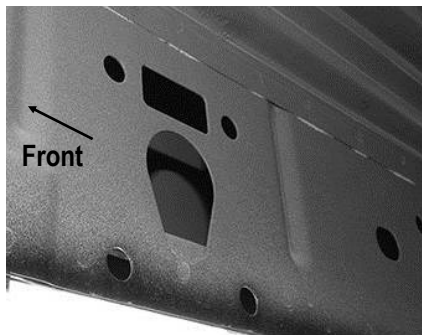

(Fig 7) Passenger Side Center Mounting Location

- (1) M10 Clip Nut
- (1) M10X1.5- 30 Hex Bolt
- (1) M10 Lock Washer
- (1) M10 Flat Washer

- (1) M10X1.5-30 Hex Bolt
- (2) M10 Flat Washers
- (1) M10 Lock Washer
- (1) M10 Hex Nut

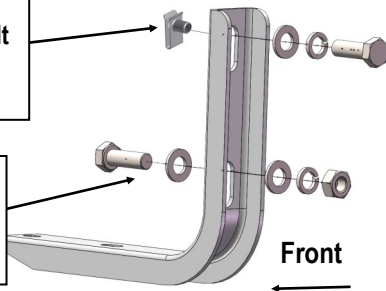

(Fig 8) Passenger Center Mounting Bracket Installed

STEP 7

Move to the Passenger Side Rear Mounting Location. Repeat **Step 6** to install the Passenger Rear Mounting Bracket **onto** the Passenger Side Rear Mounting location at the back of the cab.

STEP 8

Once all (3) Brackets have been fully installed, attach the Assembled Passenger Side Step Bar onto the brackets with (4) M6X1-20 T-Bolts, (2) M6X1-20 Square Head Bolts, (6) M6 Large Flat Washers and (6) M6 Nylon Lock Nuts, (Fig 9). Do not fully tighten hardware at this time.

STEP 9

Properly level and adjust the Step Bar and fully tighten all hardware.

STEP 10

Move to the Driver side of the vehicle. Repeat **Steps 2-9** for the Driver Side Step Bar installation.

Attention

Do periodic inspections to the installation to make sure that all hardware is secure and tight.

In order to protect your bars/boards, please use only mild soap/non-abrasive products for cleaning.

iArmor[®]

(Fig 9) Passenger Side Step Bar Installation

- (2) M6X1-20 Square Head Bolts
- (2) M6 Large Flat Washers
- (2) M6 Nylon Lock Nuts

