

IARMOR EDGE™

PART#: IA-N010

BEFORE INSTALLATION

REMOVE CONTENTS FROM BOX. VERIFY ALL PARTS ARE PRESENT. READ INSTRUCTIONS CAREFULLY BEFORE STARTING INSTALLATION. ASSISTANCE IS RECOMMENDED. THANK YOU FOR CHOOSING OUR PRODUCT!

*DRILLING NOT REQUIRED

*TRIMMING NOT REQUIRED

Fastener Size	Tightening Torque (ft-lbs)	Required
6mm	6-7	√
8mm	16-18	√
10mm	31-32	X
12mm	56-58	X
14mm	92-94	X

Item	QTY	Description	Item	QTY	Description
1#	2	Driver Front / Rear Mounting Brackets	6#	4	M8 Clip Nuts
2#	2	Passenger Front / Rear Mounting Brackets	7#	24	M6X1-20 T-Bolts
3#	8	M8X1.25-25 Hex Bolts	8#	24	M6 Large Flat Washers
4#	12	M8 Large Flat Washers	9#	24	M6X1 Nylon Lock Nuts
5#	4	M8X1.25 Nylon Lock Nuts			

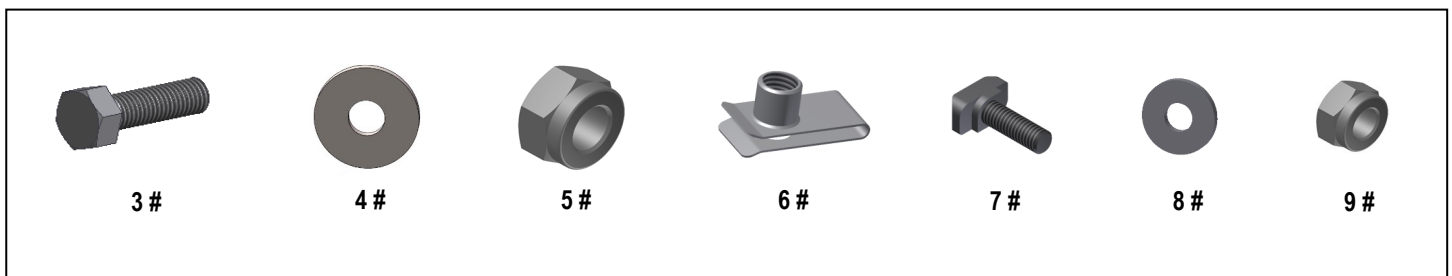

iArmor[®]

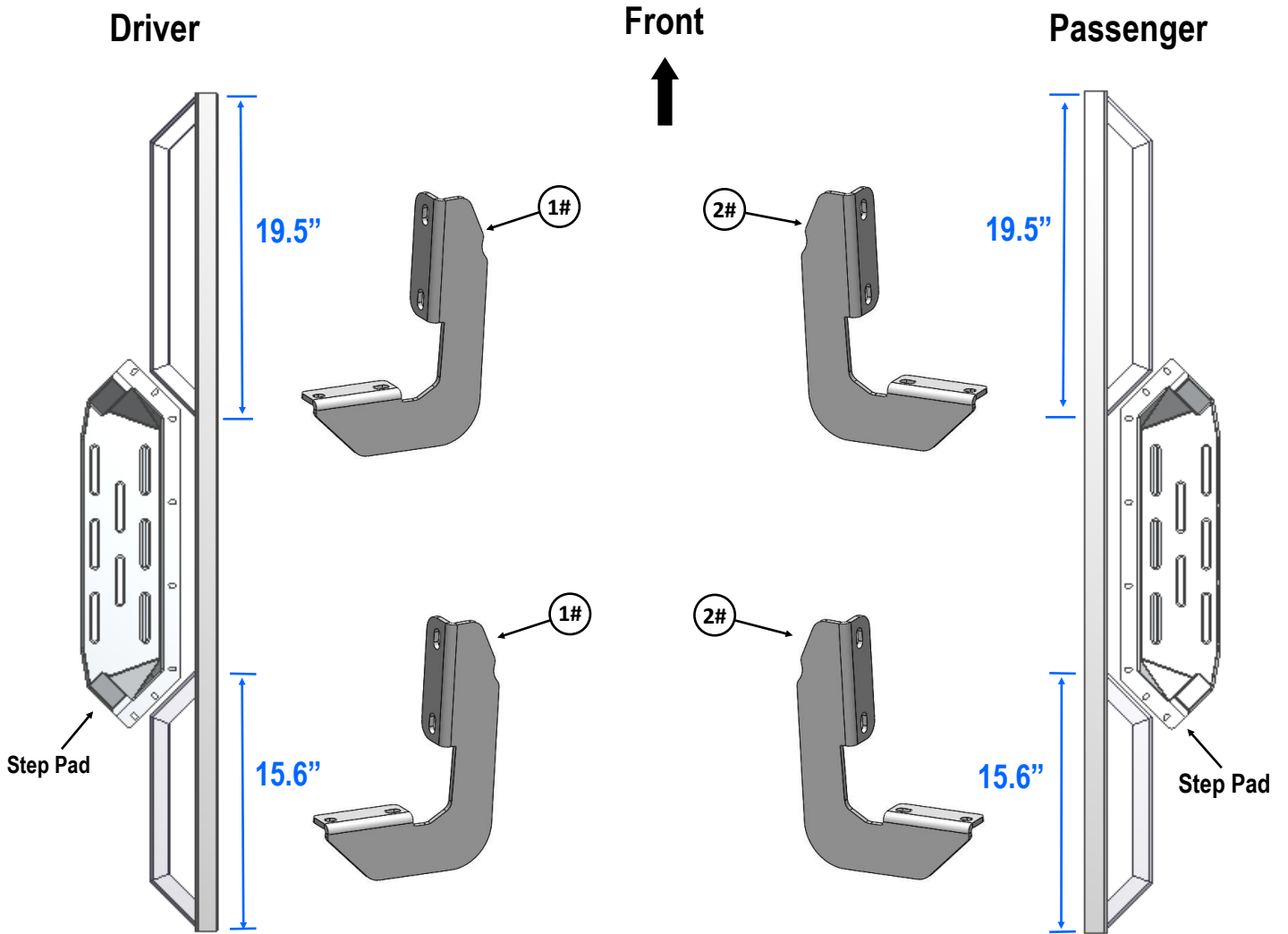

iArmor[®]

The instruction here is for your reference only. We strongly recommend the professional installer for best result. We are not responsible for any damage caused by the installation.

STEP 1

Install the Step Pads onto the step bars with (16) M6x1-20 T-Bolts, (16) M6 Flat Washers and (16) M6x1 Nylon Lock Nuts.

IMPORTANT: Don't hit the step pad by any metal hammer within step pad installation, or the step pad will be damaged.

(8) M6X1-20mm T-Bolts
(8) M6 Flat Washers
(8) M6 Nylon Lock Nuts

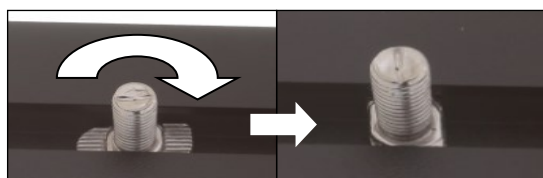

Note: Rotate 90° after inserting the T-Bolts into the Channel!!!

STEP 2

Starting from the passenger side of the vehicle, locate the passenger side mounting locations, (Figs 1 & 2).

NOTE: The mounting holes may be covered by sealing tapes or insulation, remove as required.

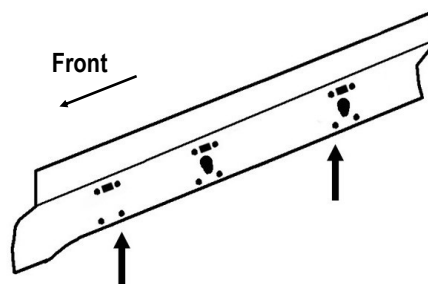

(Fig 1) Passenger Side Mounting Locations

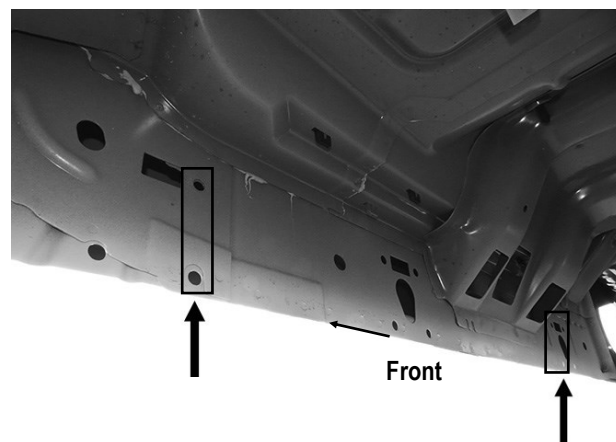

(Fig 2) Passenger Side Mounting Locations

STEP 3

Locate the Passenger Side Front Mounting Location, insert (1) M8 Clip Nut into the rectangular opening with the nut towards the inside. Line up the threaded nut on the clip with the round hole toward the rear, (Fig 3).

STEP 4

Attach the Passenger Front Mounting Bracket onto the installed M8 Clip Nut with (1) M8 Clip Nut, (1) M8X1.25-25 Hex Bolt and (1) M8 Large Flat Washer, (Fig 4).

Next, secure the lower mounting hole on the bracket to the pinch weld with (1) M8X1.25-25 Hex Bolt, (2) M8 Large Flat Washers and (1) M8X1.25 Nylon Lock Nut, (Fig 4).

iArmor®

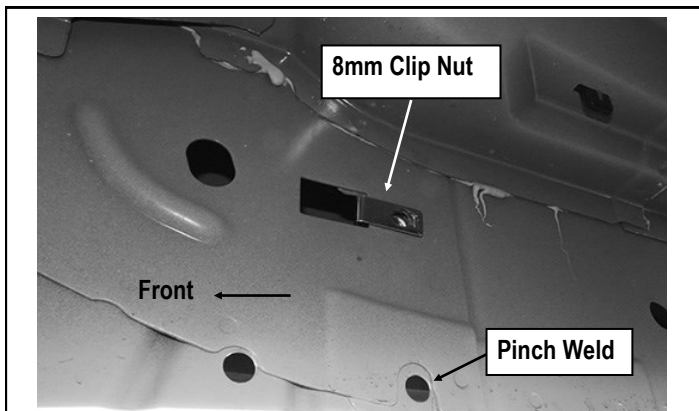

(Fig 3) M8 Clip Nut Installed
(On Passenger Front Mounting Location)

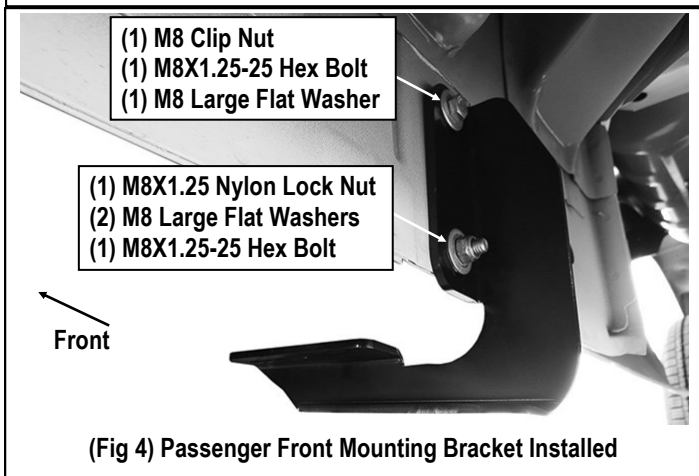

(Fig 4) Passenger Front Mounting Bracket Installed

STEP 5

Move to the Passenger Side Rear Mounting Location. Repeat **Steps 3-4** to attach the Passenger Rear Mounting Bracket to the vehicle. Do not fully tighten hardware at this time.

STEP 6

Once (2) passenger side brackets are installed, attach the Assembled Passenger Side Step Bar onto the Mounting Brackets with (4) M6X1-20 T-Bolts, (4) M6 Large Flat Washers and (4) M6x1 Nylon Lock Nuts, (**Fig 5**). Do not fully tighten hardware.

STEP 7

Properly level and adjust the Step Bar and fully tighten all hardware.

Move to the Driver side of the vehicle. Repeat **Steps 2-6** for the Driver Side Step Bar installation.

Attention

Do periodic inspections to the installation to make sure that all hardware is secure and tight.
In order to protect your bars/boards, please use only mild soap/non-abrasive products for cleaning.

(Fig 5) Passenger Side Step Bar Installation

