

iArmor®

IARMOR EDGE™

PART#: IA-N189

BEFORE INSTALLATION

REMOVE CONTENTS FROM BOX. VERIFY ALL PARTS ARE PRESENT. READ INSTRUCTIONS CAREFULLY BEFORE STARTING INSTALLATION. ASSISTANCE IS RECOMMENDED. THANK YOU FOR CHOOSING OUR PRODUCT!

*DRILLING NOT REQUIRED

*TRIMMING NOT REQUIRED

Torque Value

Fastener Size	Tightening Torque (ft-lbs)	Required
6mm	6-7	√
8mm	16-18	√
10mm	31-32	X
12mm	56-58	X
14mm	92-94	X

PART LIST

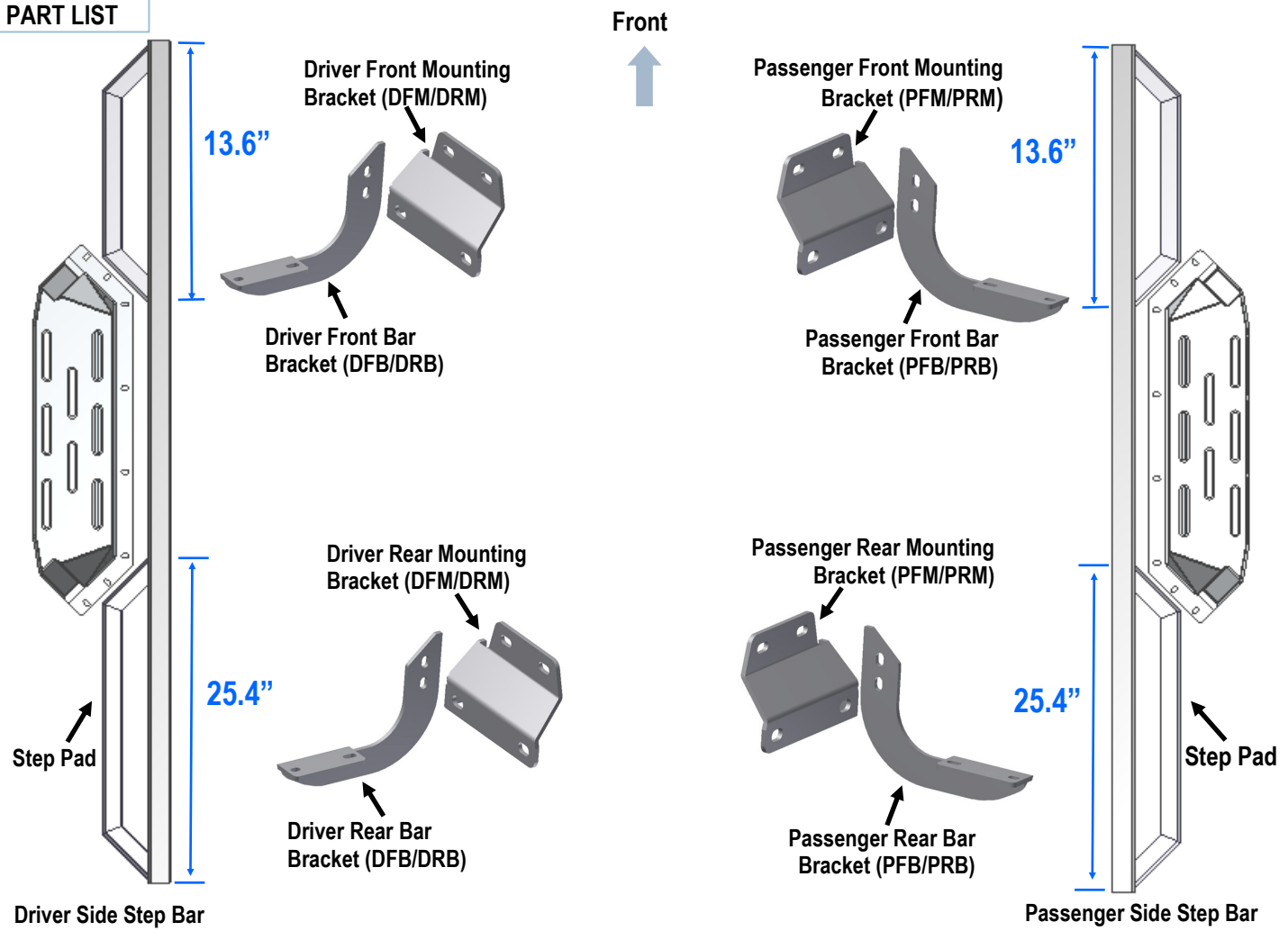

Customer Support: info@iarmorauto.com

iArmor[®]



M8 Plastic Washer



M8 Flat Washer



M8X1.25 Nylon Lock Nut



M8X1.25-20mm Round Head Bolt



M6X1-20mm T-Bolt



M6X1 Nylon Lock Nut



M6 Large Flat Washer

The instruction here is for your reference only. We strongly recommend the professional installer for best result. We are not responsible for any damage caused by the installation.

STEP 1

Install the Step Pads onto the step bars with (16) M6X1-20mm T-Bolts, (16) M6 Large Flat Washers and (16) M6X1 Nylon Lock Nuts.

IMPORTANT: Don't hit the step pad by any metal hammer within step pad installation, or the step pad will be damaged.

(8) M6X1-20 T-Bolts
(8) M6 Flat Washers
(8) M6 Nylon Lock Nuts

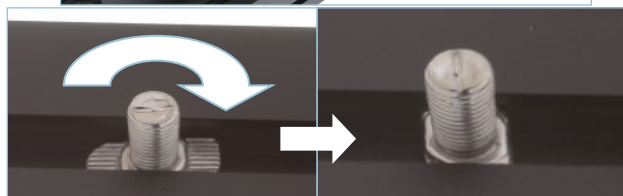

Note: Rotate 90° after inserting the T-Bolts into the Channel!!!

STEP 2

Starting from the Driver front of the vehicle, locate the threaded mounting studs in the rocker panel, (Fig 1). **Clean mounting studs with wire brush to remove paint and debris.**

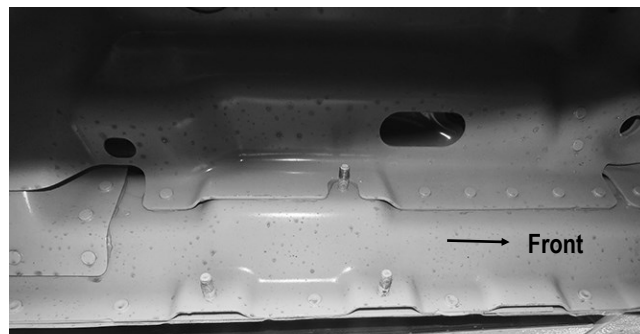

(Fig 1) Driver Side Front Mounting Location Pictured

STEP 3

Slide (1) M8 Plastic Washer over each of the (3) factory mounting studs in the rocker panel. **IMPORTANT:** The Plastic Washers are designed to prevent corrosion between the aluminum rocker panel and the steel mounting brackets. **Do not install the Brackets without the Plastic Washers.**

Customer Support: info@iarmorauto.com

iArmor®

STEP 4

Attach the Driver Front Bar Bracket (**DFB/DRB**) on the Driver Front Mounting Bracket (**DFM/DRM**) with (2) M8X1.25-20mm Round Head Bolts, (2) M8 Flat Washers and (2) M8X1.25 Nylon Lock Nuts, (**Fig 2**).

Note: Driver side brackets are universal.

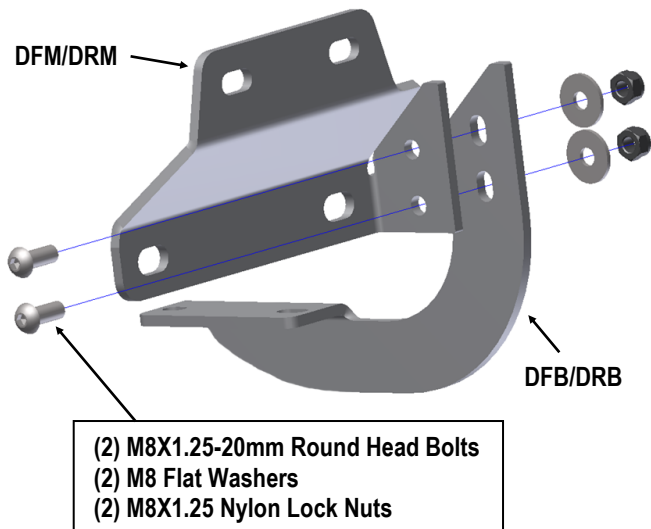

(Fig 2) Driver Side Front Mounting Bracket Assembly

STEP 5

Attach the Assembled Driver Front Mounting Bracket to the factory studs with (3) M8 Flat Washers and (3) M8X1.25 Nylon Lock Nuts, (**Fig 3**). Do not fully tighten hardware at this time.

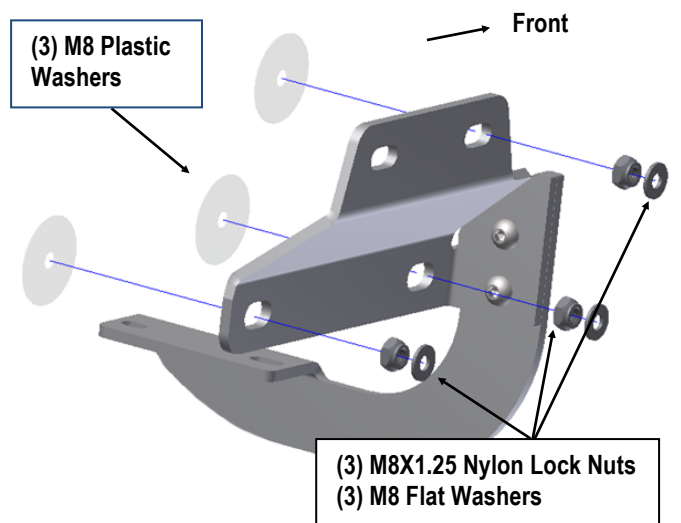

(Fig 3) Driver Side Front Mounting Bracket Installed

STEP 6

Move to Driver Side Rear Mounting Location (**Fig 4**). Repeat **Steps 4—5** to install the Assembled Driver Rear Mounting Bracket (**DFM/DRM**). Do not fully tighten hardware at this time.

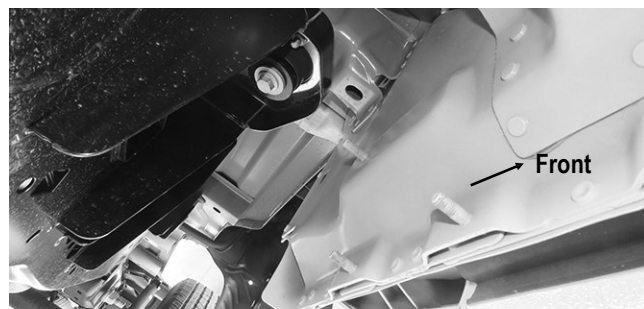

(Fig 4) Driver Side Rear Mounting Location

iArmor[®]

STEP 7

Once all (2) Brackets have been installed, attach the assembled Driver Side Step Bar to the Mounting Brackets with (4) M6X1-20mm T-Bolts, (4) M6 Large Flat Washers & (4) M6X1 Nylon Lock Nuts, (Fig 5). Do not tighten hardware at this time.

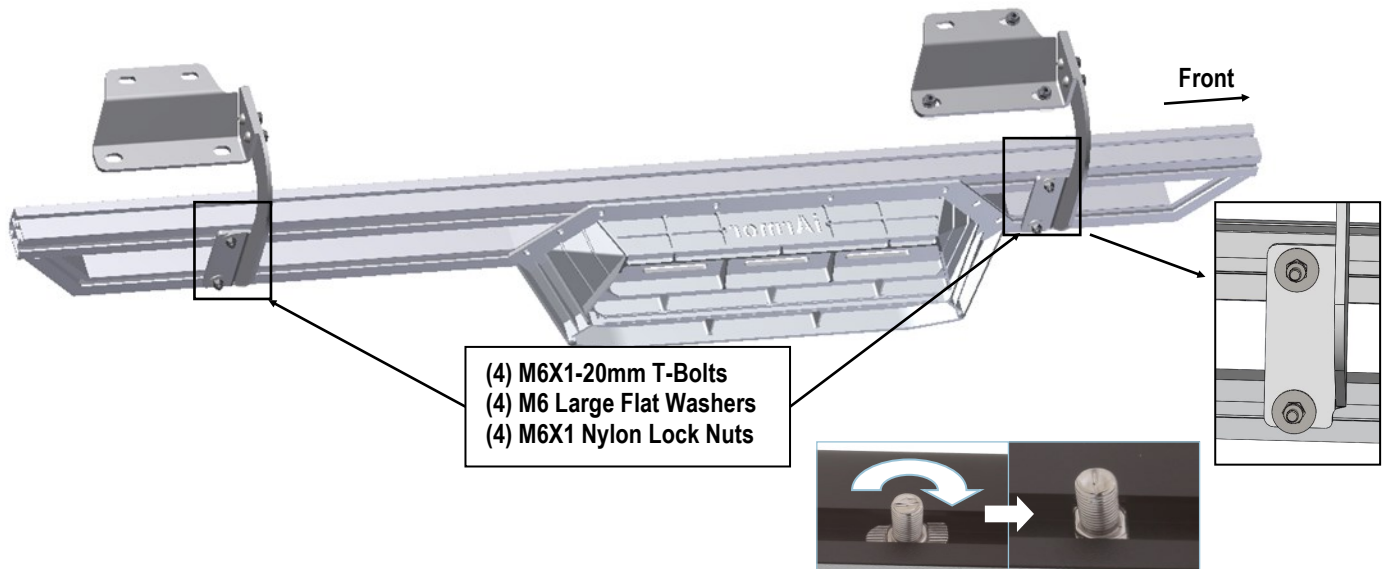

(Fig 5) Assembled Driver Side Step Bar Installed

STEP 8

Properly level and adjust the Step Bar and fully tighten all hardware.

STEP 9

Move to the passenger side of the vehicle. Repeat **Steps 2-8** to install the passenger side step bar.

Attention

Do periodic inspections to the installation to make sure that all hardware is secure and tight.

In order to protect your bars/boards, please use only mild soap/non-abrasive products for cleaning.