

## IARMOR EDGE™

PART#: IA-N152

### BEFORE INSTALLATION

REMOVE CONTENTS FROM BOX. VERIFY ALL PARTS ARE PRESENT. READ INSTRUCTIONS CAREFULLY BEFORE STARTING INSTALLATION. ASSISTANCE IS RECOMMENDED. THANK YOU FOR CHOOSING OUR PRODUCT!

\*DRILLING IS REQUIRED

\*TRIMMING NOT REQUIRED

### Torque Value

Fastener Size	Tightening Torque (ft-lbs)	Required
6mm	6-7	√
8mm	16-18	√
10mm	31-32	√
12mm	56-58	X
14mm	92-94	X

### PART LIST

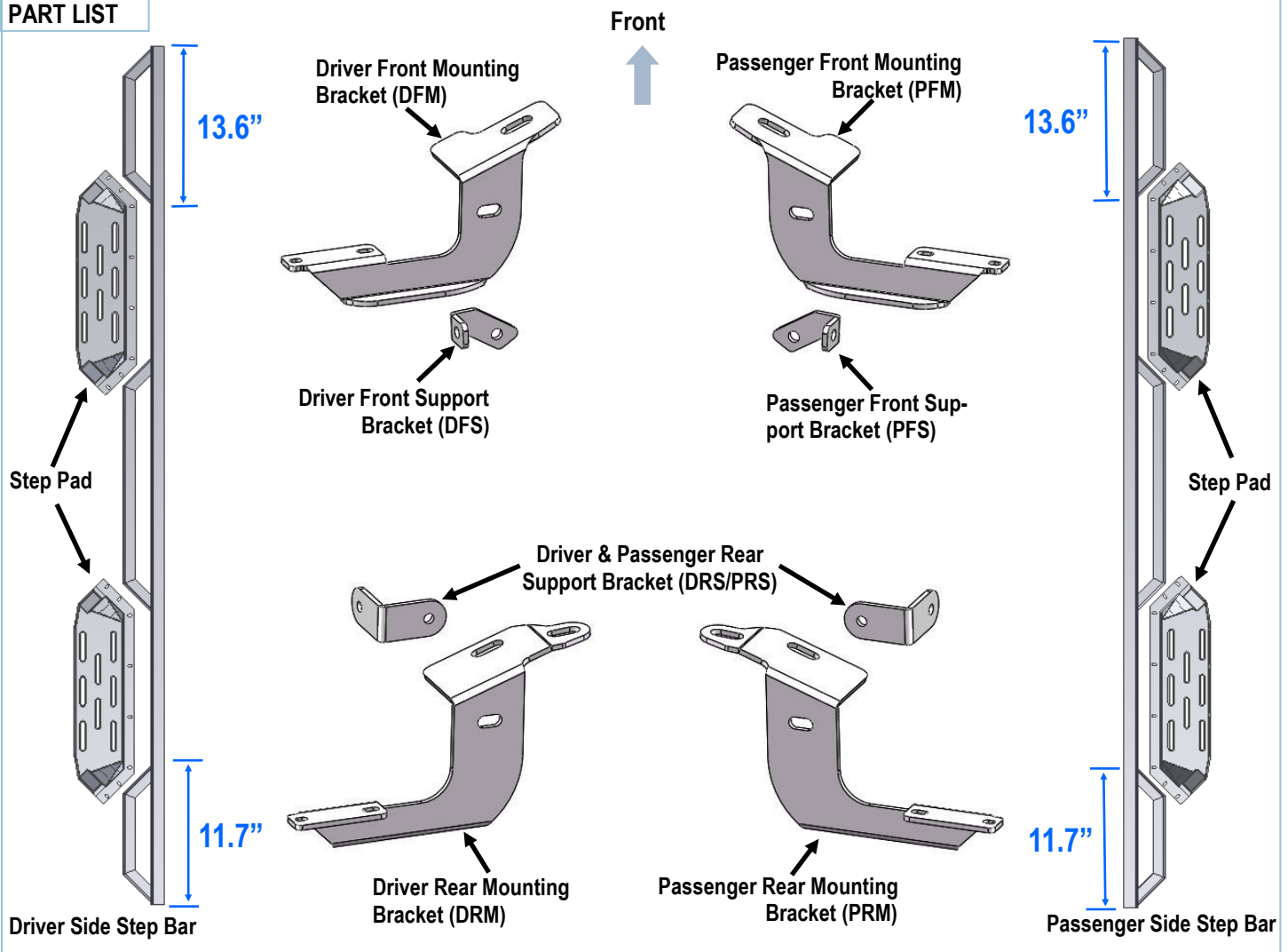

Customer Support: [info@iarmorauto.com](mailto:info@iarmorauto.com)

# iArmor®

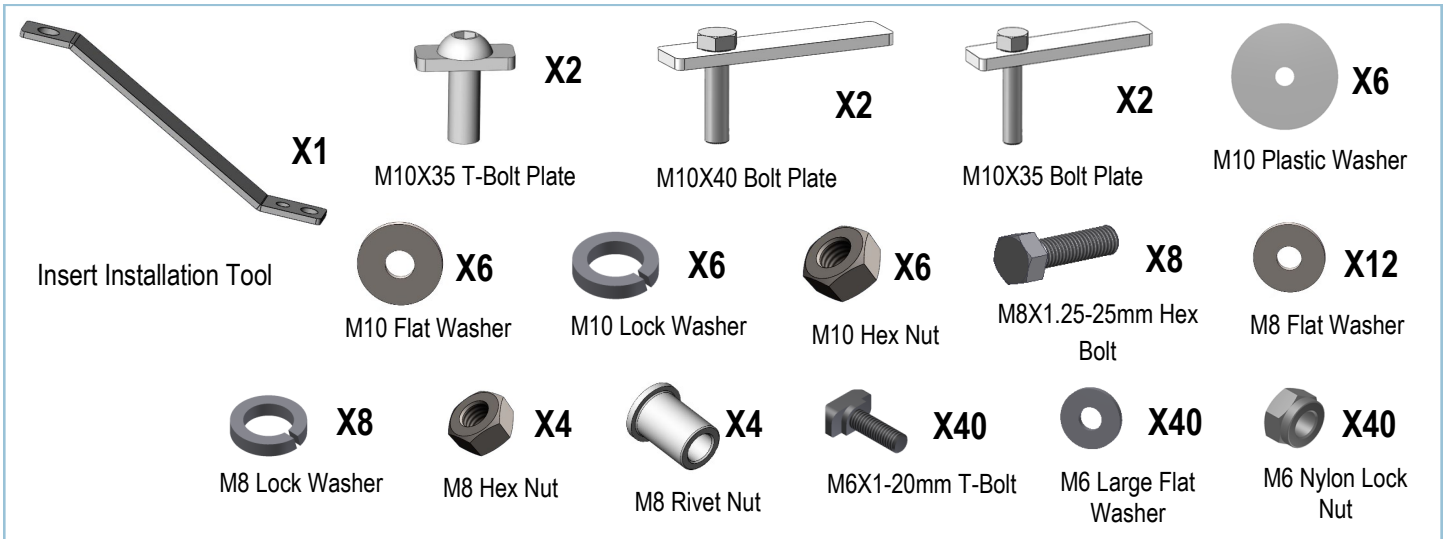

The instruction here is for your reference only. We strongly recommend the professional installer for best result. We are not responsible for any damage caused by the installation.

## STEP 1

Install the Step Pads onto the step bars with (32) M6X1-20mm T-Bolts, (32) M6 Large Flat Washers and (32) M6 Nylon Lock Nuts.  
**IMPORTANT:** Don't hit the step pad by any metal hammer within step pad installation, or the step pad will be damaged.

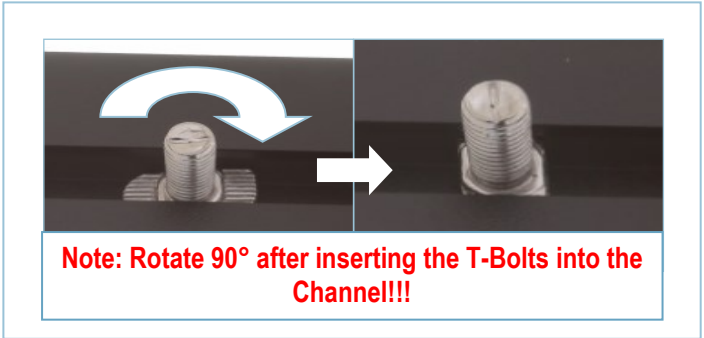
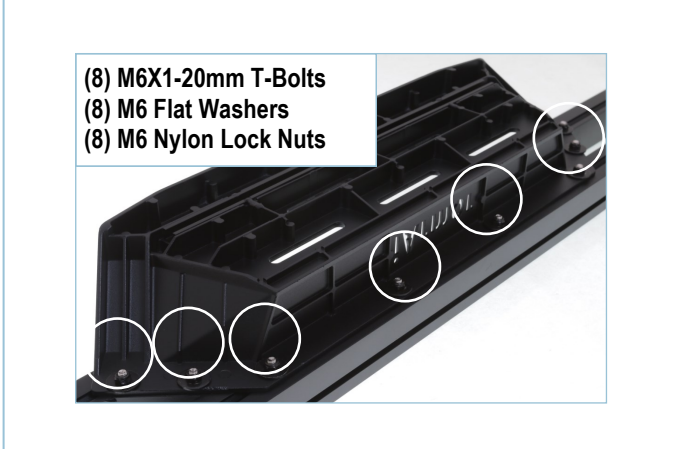

## STEP 2

Start installation under the driver side front of the vehicle. Select and insert (1) M10X35 T-Bolt Plate into the factory oval hole in the floor panel, (**Figs 1A & 1B**). Rotate the Bolt Plate 90-degrees so that the plate is across in the oval hole. Hang the Driver Front Mounting Bracket (**DFM**) to the installed M10X35 T-Bolt Plate with (1) M10 Flat Washer, (1) M10 Lock Washer and (1) M10 Hex Nut, (**Fig 2**).

**NOTE:** Make sure that the mounting flange on the front Bracket is lined up properly with the indent in the floor panel. The front Mounting Bracket must sit flat against the floor panel. Do not fully tighten hardware at this time.

# iArmor®

M10 X 35 T-Bolt Plate

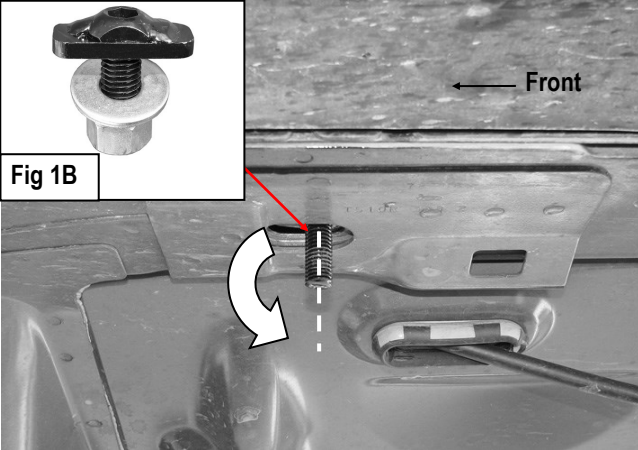

(Fig 1A) M10X35 T-Bolt Plate Installation

- (1) M10 Flat Washer
- (1) M10 Lock Washer
- (1) M10 Hex Nut

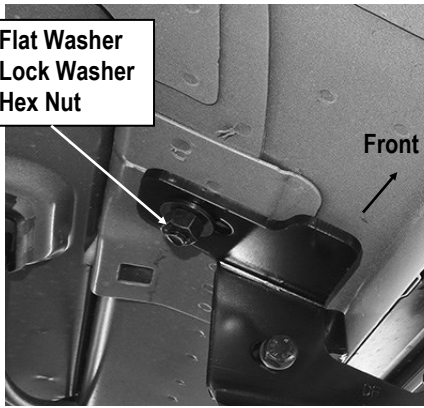

(Fig 2) Driver Front Mounting Bracket Installed

## STEP 3

Select the Driver Front Support Bracket (DFS), (Fig 3A). Bolt the Driver Front Support Bracket to the back of the Driver Front Mounting Bracket with (1) M8X1.25-25mm Hex Bolt, (2) M8 Flat Washers, (1) M8 Lock Washer and (1) M8 Hex Nut, (Figs 3 & 4).

**Note:** Line up the mounting tab on the Support Bracket to the inner side of the pinch weld. Do not fully tighten hardware at this time.

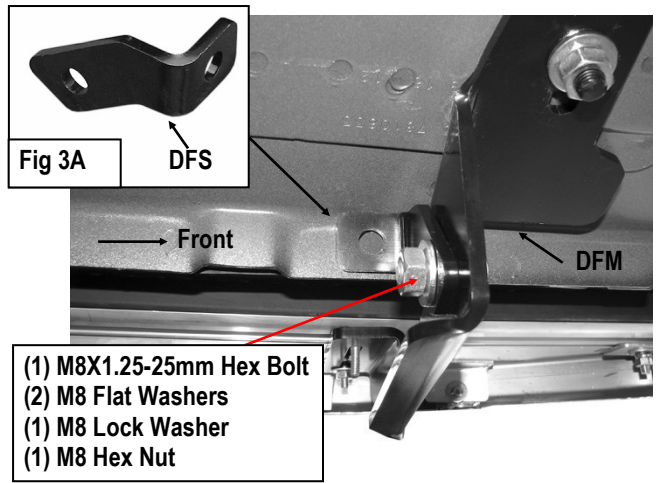

- (1) M8X1.25-25mm Hex Bolt
- (2) M8 Flat Washers
- (1) M8 Lock Washer
- (1) M8 Hex Nut

(Fig 3) Attach Driver Front Support Bracket to Driver Front Mounting Bracket

- (1) M10 Flat Washer
- (1) M10 Lock Washer
- (1) M10 Hex Nut
- (1) M8X1.25-25mm Hex Bolt
- (2) M8 Flat Washers
- (1) M8 Lock Washer
- (1) M8 Hex Nut

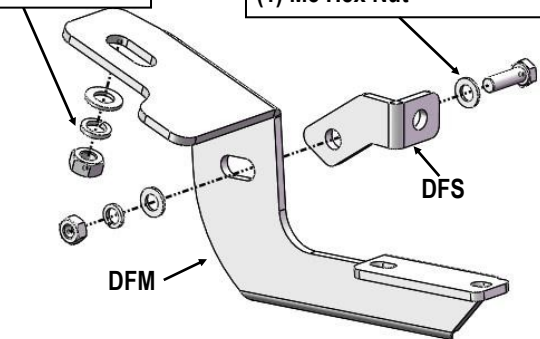

(Fig 4) Driver Side Front Brackets Installation

## STEP 4

Move to the Driver Side Rear Mounting Location. Locate the oval and round holes on the floor panel, (Fig 5A). Insert (1) M10X35 Bolt Plate into the round hole, (Fig 5B). Insert (1) M10X40 Bolt Plate into the oval hole next to the pinch weld, (Fig 5C). Rotate 90-degree for the M10X40 Bolt Plate till the plate across on the oval hole.

# iArmor®

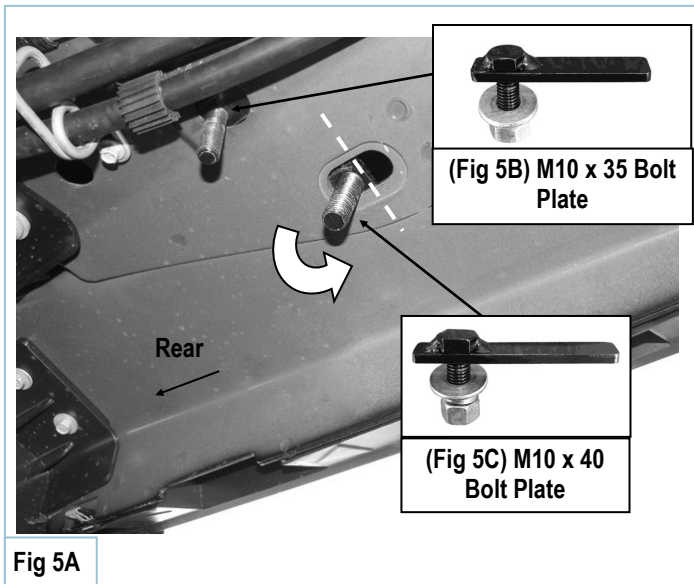
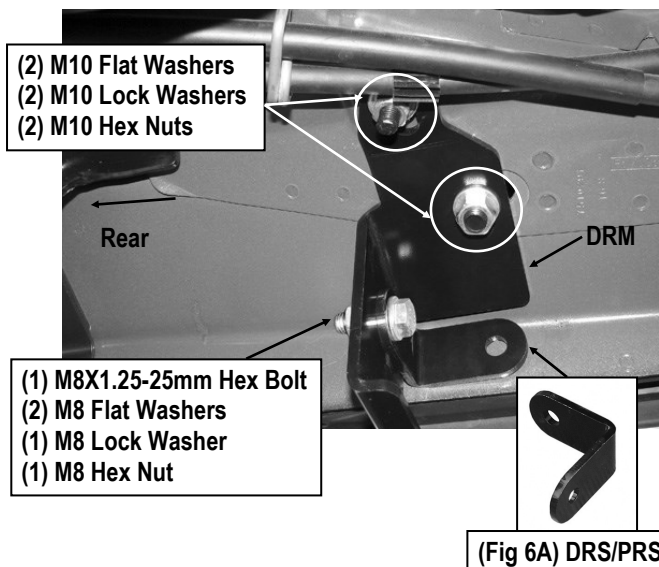

Fig 5A

## STEP 5

Attach the Driver Rear Mounting Bracket (**DRM**) to the (2) installed M10 Bolt Plates with (2) M10 Flat Washers, (2) M10 Lock Washers and (2) M10 Hex Nuts, (**Fig 6**). Do not fully tighten hardware at this time.



(Fig 6) Driver Rear Mounting Bracket Installation

## STEP 6

Next, select (1) Driver Rear Support Bracket (**DRS/PRS**), (**Fig 6A**). Bolt the Support Bracket to the front side of the Driver Rear Mounting Bracket (**DRM**) with (1) M8X1.25-25mm Hex Bolt, (2) M8 Flat Washers, (1) M8 Lock Washer and (1) M8 Hex Nut, (**Figs 6 & 7**). Do not fully tighten hardware at this time.

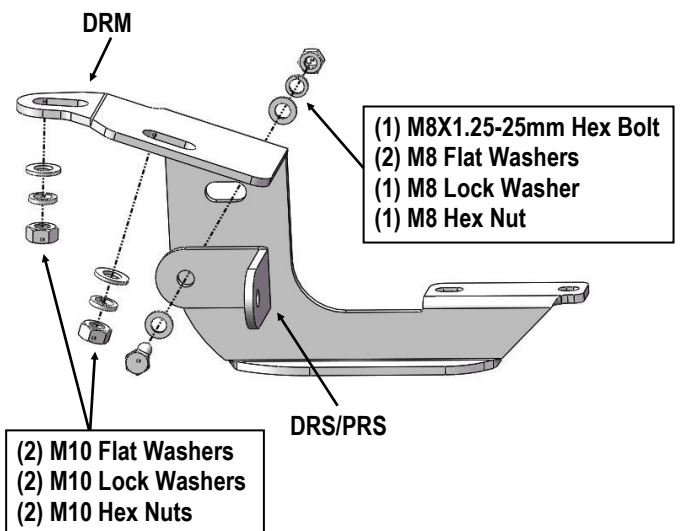

(Fig 7) Driver Side Rear Brackets Installation

## STEP 7

Once all (2) Driver side brackets are installed, select and attach the Driver Side Step Bar onto the Mounting Brackets with (4) M6X1-20mm T-Bolts, (4) M6 Large Flat Washers and (4) M6 Nylon Lock Nuts, (**Fig 8**). Do not fully tighten hardware at this time.

**NOTE:** Level and adjust the Running Board and tighten the Mounting Brackets to Bolt Plate only. Do not tighten the hardware for the front and rear Support Brackets at this time.

# iArmor®

(Fig 8) Driver Side Step Bar Installation

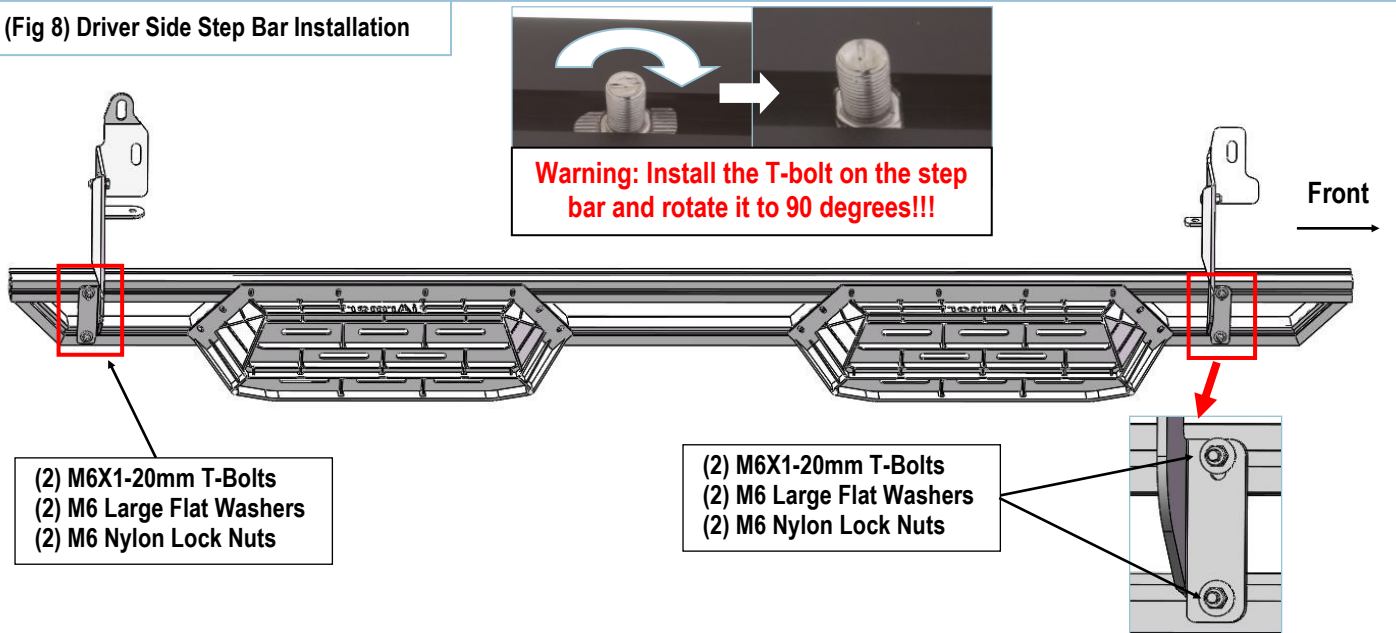

## STEP 8

Return to the Driver Front Mounting Bracket (DFM) and Driver Front Support Bracket (DFS). Hold the Front Support Bracket firmly against the inner of the pinch weld. Mark the mounting hole location onto the inner side of the pinch weld, (Fig 9).

Make sure the Running Board is level, and then drill a  $7/16$ " hole on the pinch weld according to the mark.

**CAUTION:** Do not drill the hole too close to the bottom edge of the pinch weld.

**VERY IMPORTANT!** Be very careful and drill slowly through the pinch weld to avoid damaging the outer trim panel.

**NOTE:** Any cutting or drilling tool may break or shatter. Government regulations require safety glasses & equipment at all times when cutting or drilling.

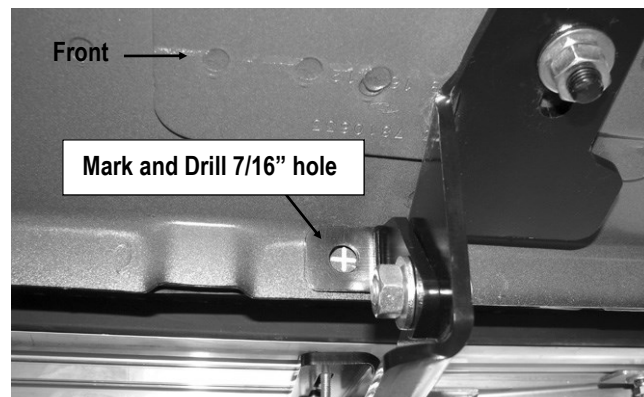

(Fig 9) Mark And Drill  $7/16$ " Hole On Pinch Weld According To The Support Bracket Location

## STEP 9

Select (1) Insert Installation Tool, (1) M8 Rivet Nut, (1) M8X1.25-25mm Hex Bolt and (1) M8 Flat Washer. Assemble the Insert Installation Tool as shown on Fig 11.

**NOTE:** Select 8 mm hole on threaded tool (Fig 10).

# iArmor®

Hold the handle and push the M8 Rivet Nut into the drilled hole in the pinch weld. **NOTE:** Insert must fit snug in hole. If necessary, use a small hammer to carefully tap the Insert into the hole until the rim on the insert is flush against the pinch weld. Firmly hold the tool handle and tighten the Hex Bolt in the Tool to expand the M8 Rivet Nut in the hole. Continue until threads are pulled up close to the top of the Insert, (Figs 11A & 14). Remove the Tool and hardware. Bolt the Support Bracket to the M8 Rivet Nut with (1) M8x1-25mm Hex Bolt, (1) M8 Lock Washer and (1) M8 Flat Washer, (Fig 12). Do not fully tighten at this time.

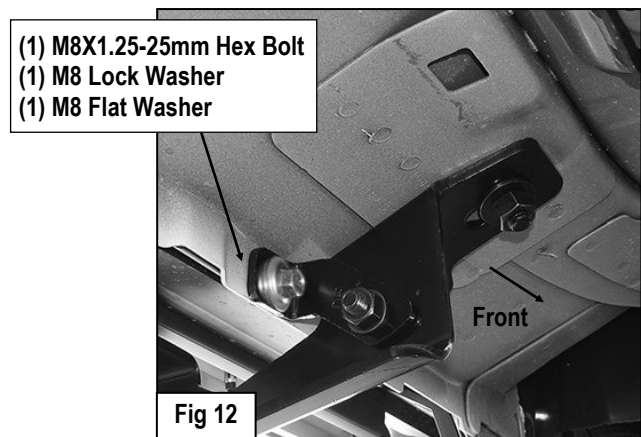
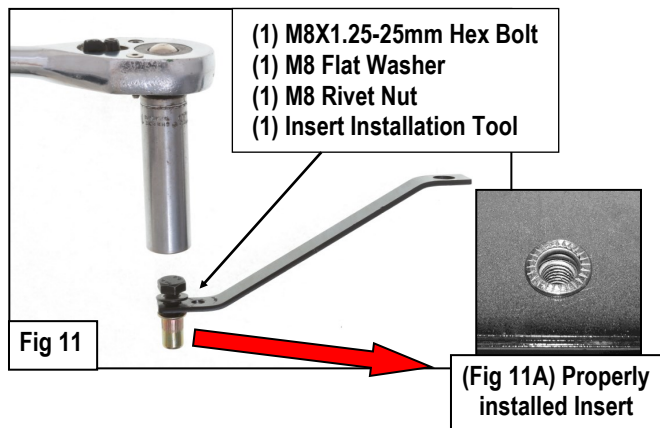
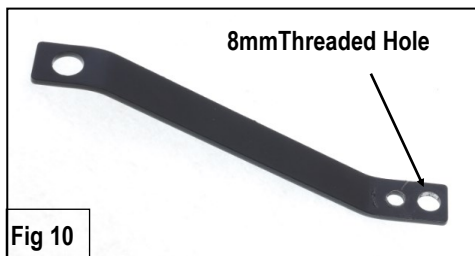

## STEP 10

Move to the driver side rear Mounting Bracket. Hold the Driver Rear Support Bracket (DRS/PRS) firmly against the back of the pinch weld. Repeat Steps 8—9 to mark and drill the pinch weld and install the M8 Rivet Nut, (Figs 13 & 14). Reinstall the Support Bracket. Bolt the Support Bracket to the Insert with (1) M8x1-25mm Hex Bolt, (1) M8 Lock Washer and (1) M8 Flat Washer, (Fig 15). Tighten the front and rear Bracket hardware only at this time.

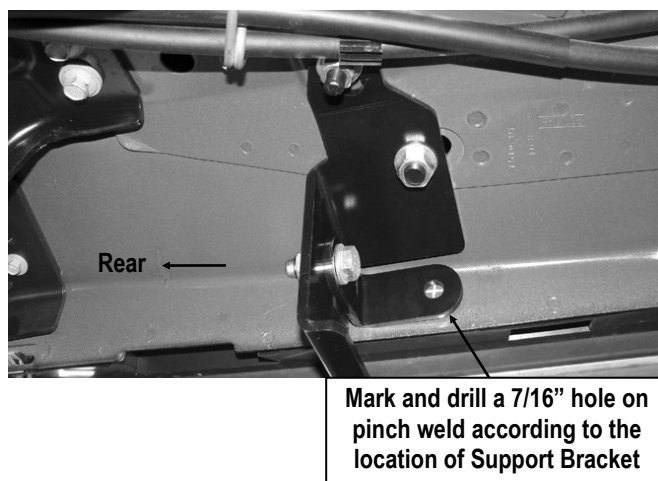

(Fig 13) Mark & Drill A Hole On The Pinch Weld According To The Driver Rear Support Bracket Location

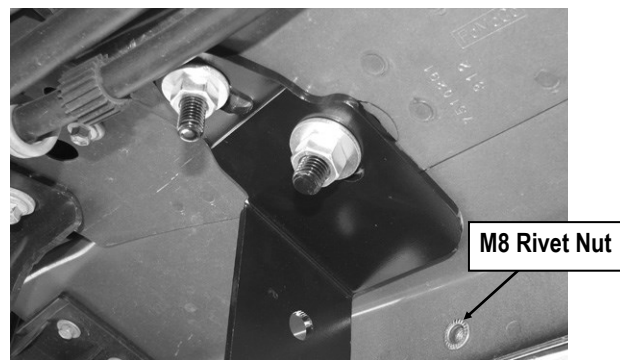

(Fig 14) M8 Rivet Nut Installed On Pinch Weld (Driver Rear Support Bracket Location)

# iArmor®

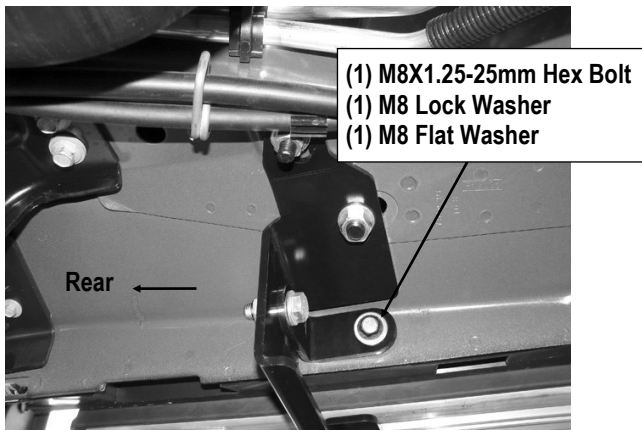

(Fig 15) Driver Rear Support Bracket Installed

## STEP 11

Properly level and adjust the Step Bar and fully tighten all hardware.

## STEP 12

Move to the other side of the vehicle. Repeat **Steps 1—11** for other side Step Bar installation.

### Attention

Do periodic inspections to the installation to make sure that all hardware is secure and tight.

In order to protect your bars/boards, please use only mild soap/non-abrasive products for cleaning.