

iArmor®

IARMOR EDGE™

PART#: IA-W159

BEFORE INSTALLATION

REMOVE CONTENTS FROM BOX. VERIFY ALL PARTS ARE PRESENT. READ INSTRUCTIONS CAREFULLY BEFORE STARTING INSTALLATION. ASSISTANCE IS RECOMMENDED. THANK YOU FOR CHOOSING OUR PRODUCT!

*ROCKER PANEL MOUNT

*DRILLING/TRIMMING NOT REQUIRED

Torque Value

Fastener Size	Tightening Torque (ft-lbs)	Required
6mm	6-7	X
8mm	16-18	√
10mm	31-32	√
12mm	56-58	X
14mm	92-94	X

PART LIST

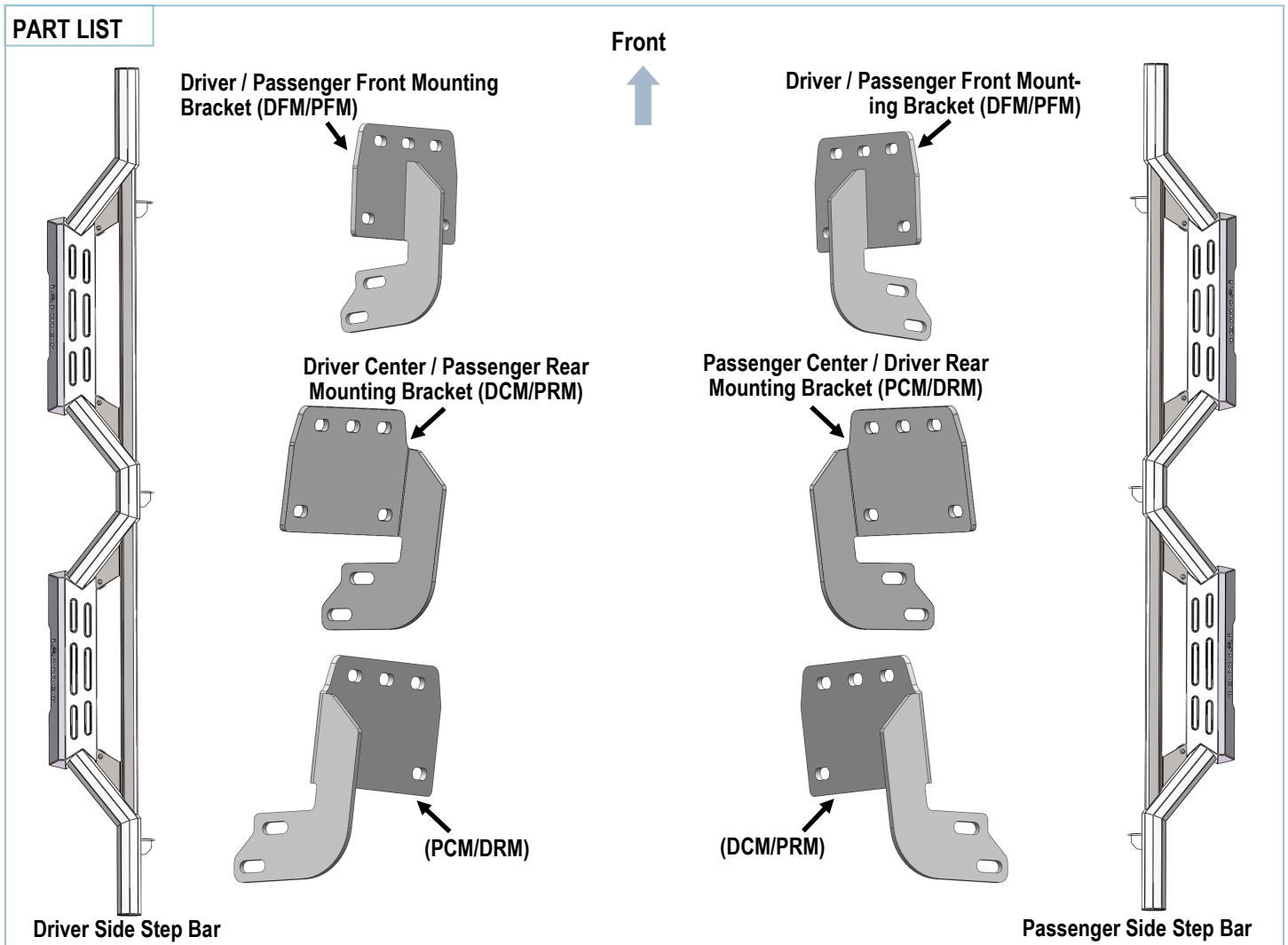

Customer Support: info@iarmorauto.com

iArmor®

Hardware Package (For Brackets & Step Bars Installation)

Item	QTY	Description	Item	QTY	Description
1#	18	M8 Large Flat Washers	4#	24	M10 Flat Washers
2#	18	M8X1.25 Nylon Lock Nuts	5#	12	M10 Nylon Lock Nuts
3#	12	M10X1.5-25 Hex Bolts			



1#



2#



3#



4#

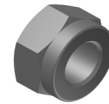

5#

iArmor®

The instruction here is for your reference only. We strongly recommend the professional installer for best result. We are not responsible for any damage caused by the installation.

STEP 1

Start the installation from the Driver side front of the vehicle. Locate the front (3) factory studs along the inner side of the body panel. (Fig 1). Use a wire brush to remove paint on the threaded studs if equipped.

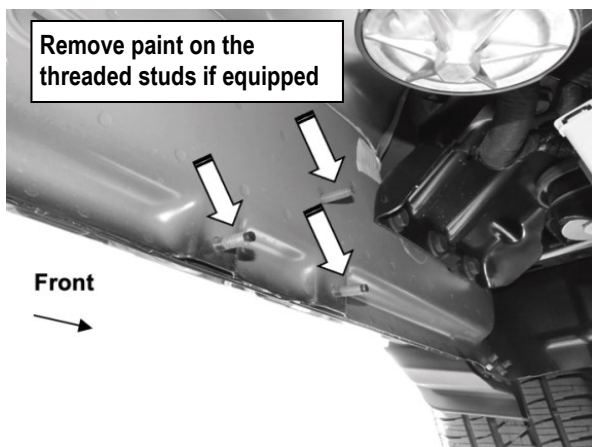

(Fig 1) Driver Side Front Mounting Location

STEP 2

Select (1) Driver Front Mounting Bracket (DFM/PFM). Attach the mounting bracket to the (3) factory studs with (3) M8 Large Flat Washers and (3) M8X1.25 Nylon Lock Nuts, (Fig 2). Do not fully tighten hardware at this time.

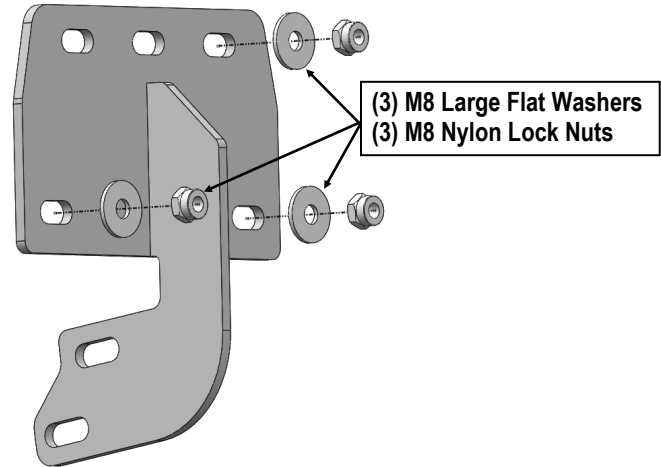

(Fig 2) Driver Front Mounting Bracket Installation

STEP 3

Repeat Steps 1-2 to install Driver Center Mounting bracket (PCM/DRM) and Driver Rear Mounting bracket (DCM/PRM), (Figs 3-6). Do not fully tighten hardware at this time.

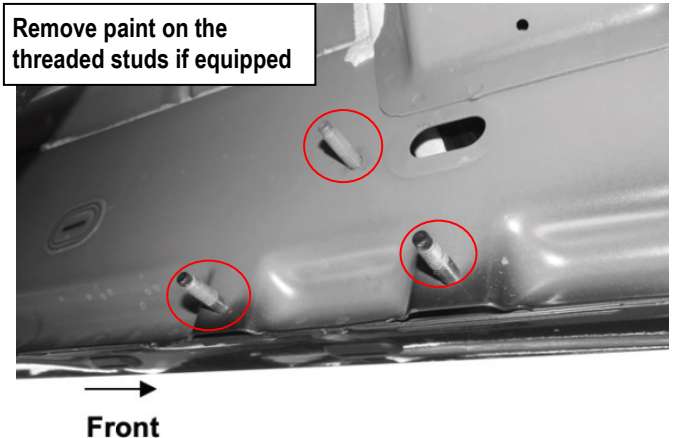

(Fig 3) Driver Side Center Mounting Location

iArmor®

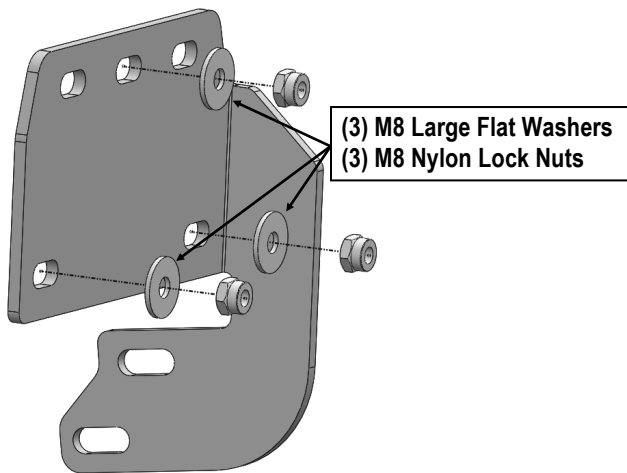

(Fig 4) Driver Center Mounting Bracket Installation

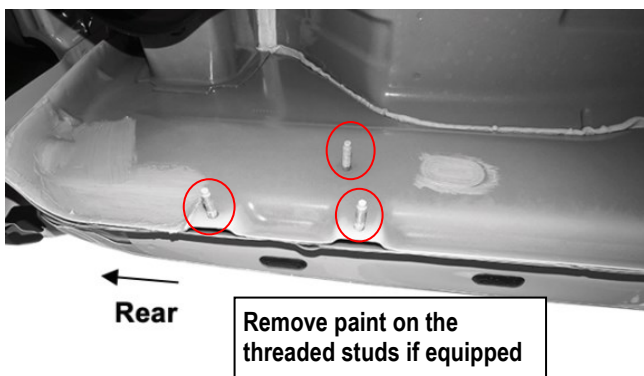

(Fig 5) Driver Rear Mounting Location

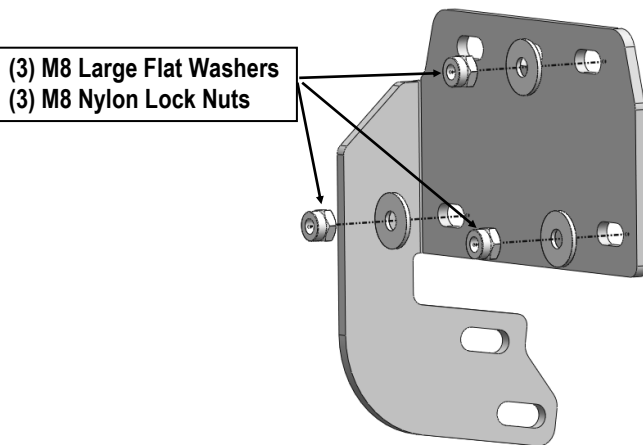

(Fig 6) Driver Rear Mounting Bracket Installation

STEP 4

Once all (3) Mounting Brackets have been installed, attach the Driver Side Step Bar to the Mounting Brackets with (6) M10X1.5-25 Hex Bolts, (12) M10 Flat Washers and (6) M10X1.5 Nylon Lock Nuts, (Fig 7). Do not fully tighten hardware at this time.

STEP 5

Properly level and adjust the Step Bar and fully tighten all hardware.

STEP 6

Move to the other side of the vehicle. Repeat **Steps 1-5** for the other Side Step Bar installation.

Attention

Do periodic inspections to the installation to make sure that all hardware is secure and tight.

In order to protect your bars/boards, please use mild soap/non-abrasive products for cleaning only.

iArmor[®]

