

iArmor[®]

iArmor[®] by APS

PART#: IA-S913

BEFORE INSTALLATION

REMOVE CONTENTS FROM BOX. VERIFY ALL PARTS ARE PRESENT. READ INSTRUCTIONS CAREFULLY BEFORE STARTING INSTALLATION. ASSISTANCE IS RECOMMENDED. THANK YOU FOR CHOOSING OUR PRODUCT!

***ROCKER PANEL MOUNT**

***NO DRILLING / TRIMMING REQUIRED**

Torque Value

Fastener Size	Tightening Torque (ft-lbs)	Required
6mm	6-7	X
8mm	16-18	√
10mm	31-32	√
12mm	56-58	X
14mm	92-94	X

PART LIST

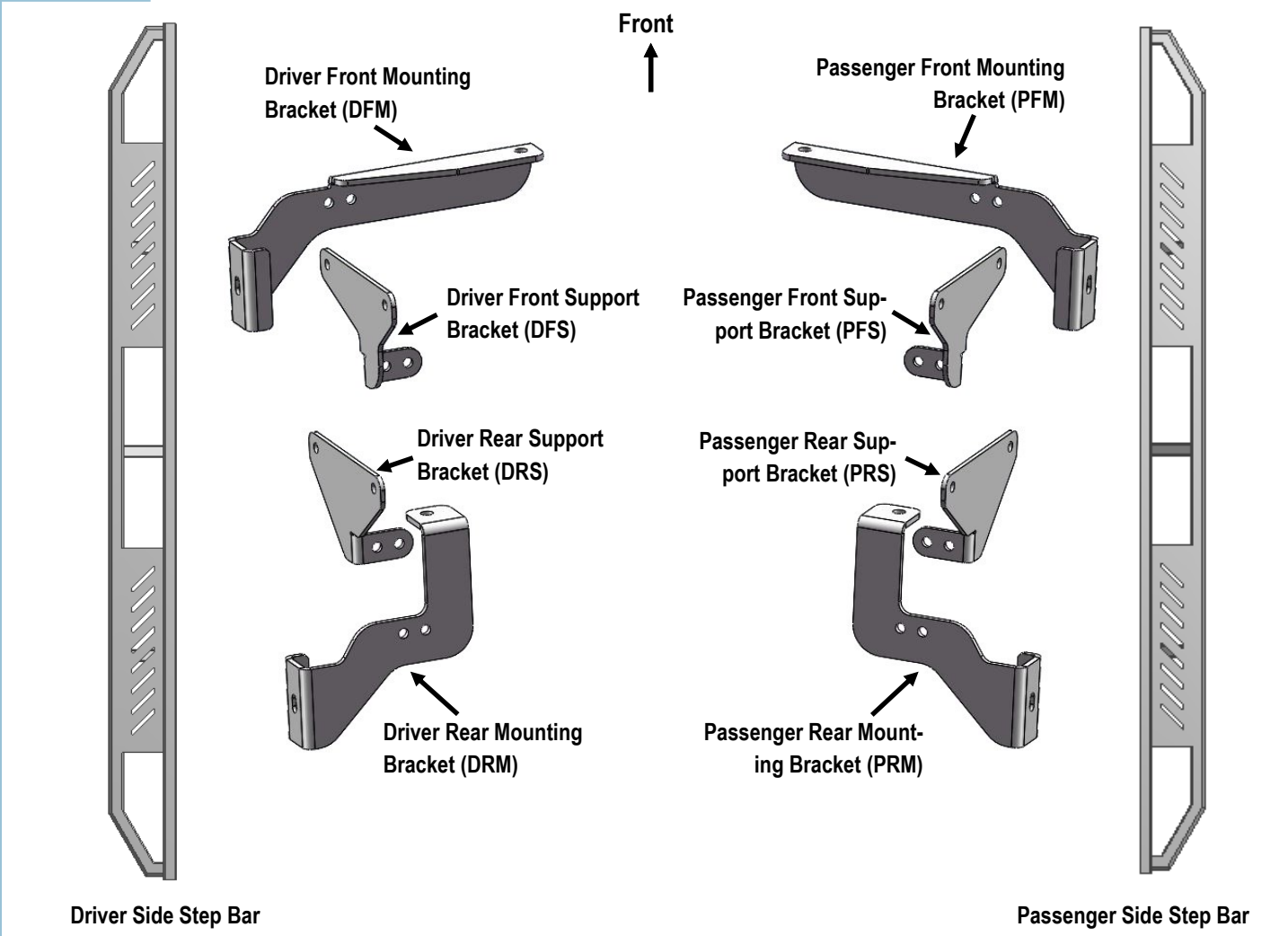

Customer Support: info@iarmorauto.com

iArmor®



The instruction here is for your reference only. We strongly recommend the professional installer for best result. We are not responsible for any damage caused by the installation.

STEP 1

Starting from the driver front side of the vehicle. Install J-Bolt in the large hole in the frame. (Fig 1, 2).

Note: Dodge Durango requires pinch weld holes used for installation to be drilled out to 3/8" and one additional hole to be drilled through the pinch weld in the rear of the vehicle, (Fig 4 & 7).

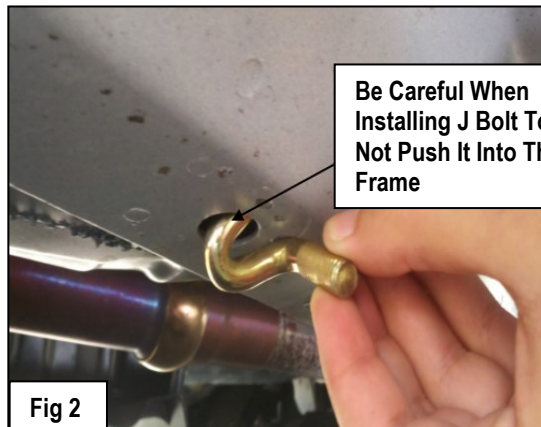
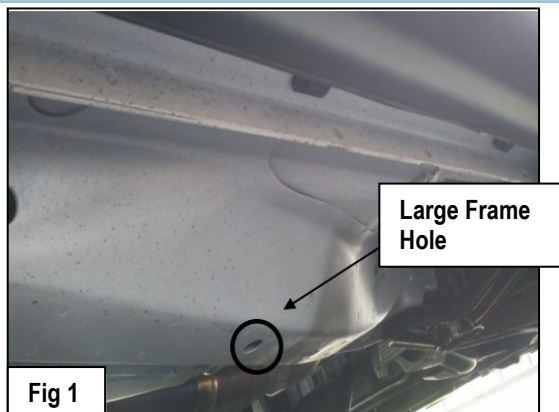

STEP 2

Assemble Driver Front Mounting Bracket (DFM) and Driver Front Support Bracket (DFS) with (2) M8X1.25-20mm Hex Bolts, (4) M8 Flat Washers, (2) M8 Lock Washers and (2) M8X1.25 Hex Nuts, (Fig 3).

iArmor[®]

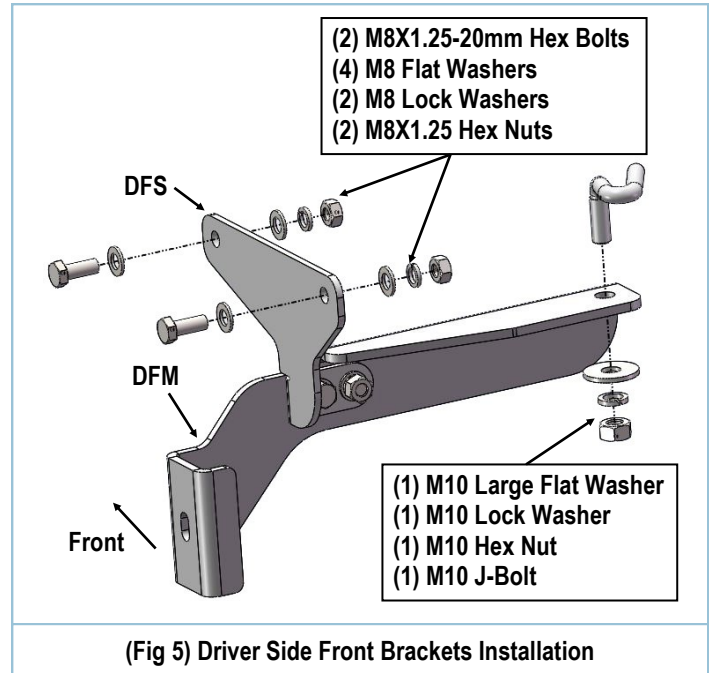
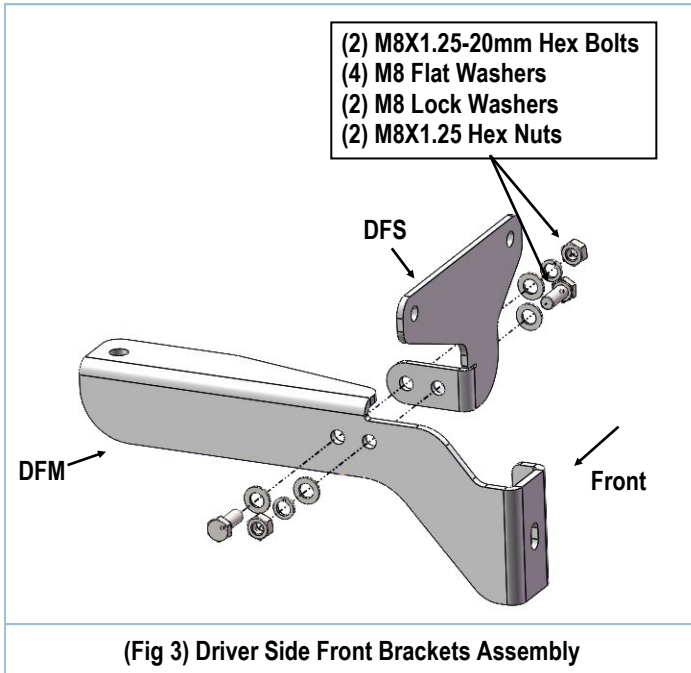

STEP 3

Install Driver Front Mounting Bracket to the J-Bolt using (1) M10 Large Flat Washer, (1) M10 Lock Washer and (1) M10 Hex Nut. Secure the Front Support Bracket to the outside of the pinch weld using (2) M8X1.25-20mm Hex Bolts, (4) M8 Flat Washers, (2) M8 Lock Washers and (2) M8X1.25 Hex Nuts. Do not tighten fully at this time, (Fig 4 & 5).

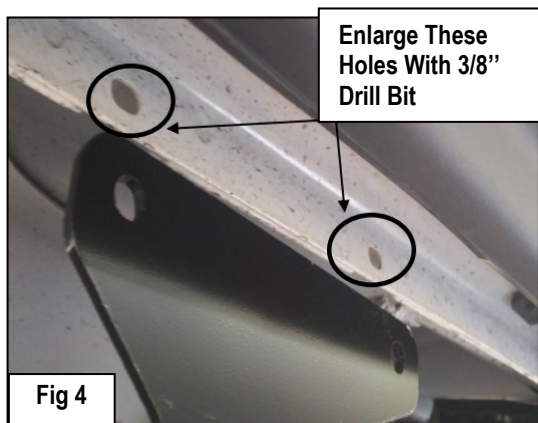

STEP 4

Assemble Driver Rear Mounting Bracket (DRM) and Driver Rear Support Bracket (DRS) with (2) M8X1.25-20mm Hex Bolts, (4) M8 Flat Washers, (2) M8 Lock Washers and (2) M8X1.25 Hex Nut, (Fig 6).

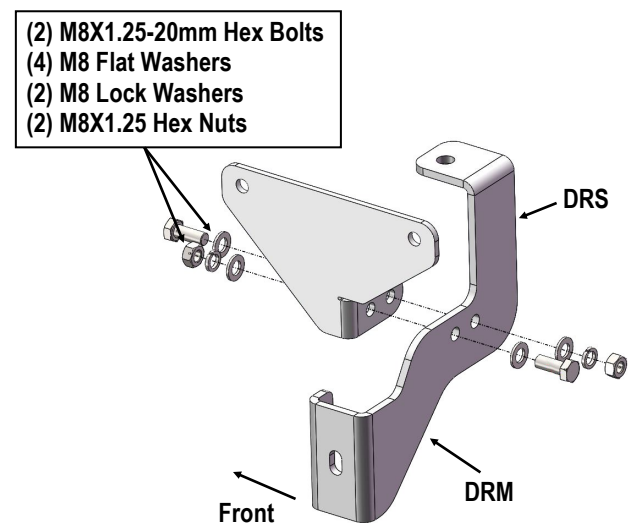

iArmor®

STEP 5

Install Driver Rear Mounting Bracket with (1) M10X1.5-35mm Hex Bolt, (1) M10 Lock Washer and (1) M10 Large Flat Washer. Secure the Rear Support Bracket to the outside of the pinch weld using (2) M8X1.25-20mm Hex Bolts, (4) M8 Flat Washers, (2) M8 Lock Washers and (2) M8X1.25 Hex Nuts. Do not tighten fully at this time, (Fig 7 & 8).

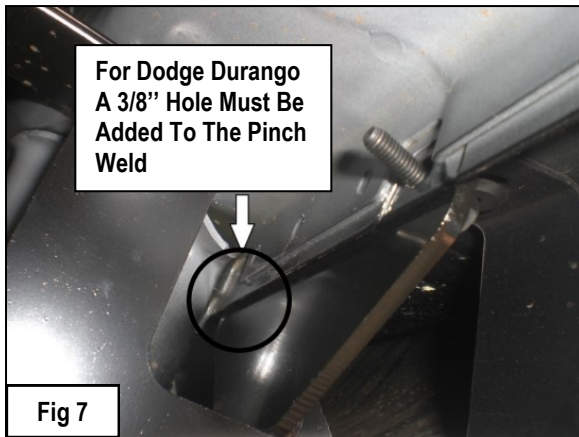
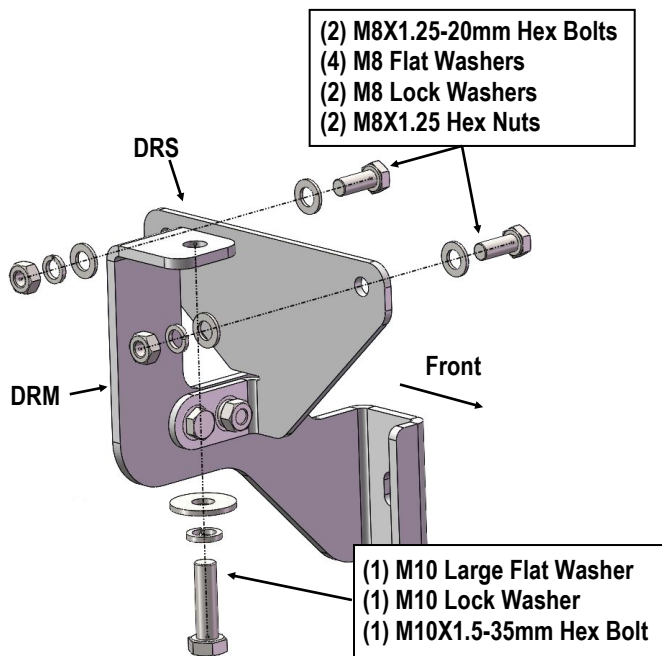

Fig 7



(Fig 8) Driver Side Rear Brackets Installation

STEP 6

Once all (2) driver side mounting brackets are installed, select and attach the Driver Side Step Bar onto the Mounting Brackets with (2) U Brackets, (4) Spacers, (2) M8X1.25-55mm Carriage Bolts, (2) M8 Large Flat Washers, (2) M8 Lock Washers and (2) M8X1.25 Hex Nuts, (Fig 9). Do not fully tighten hardware at this time.

STEP 7

Properly level and adjust the Step Bar and fully tighten all hardware.

STEP 8

Move to the passenger side of the vehicle. Repeat **Steps 1-7** to install passenger side step bar. Installation completed.

Attention

Do periodic inspections to the installation to make sure that all hardware is secure and tight.

In order to protect your bars/boards, please use only mild soap/non-abrasive products for cleaning.

iArmor®

NOTE: Torque all M8 X1.25-55mm Carriage Bolts to 16~18 lb-ft. Don't over tighten, or the aluminum square bars will be damaged by the brackets

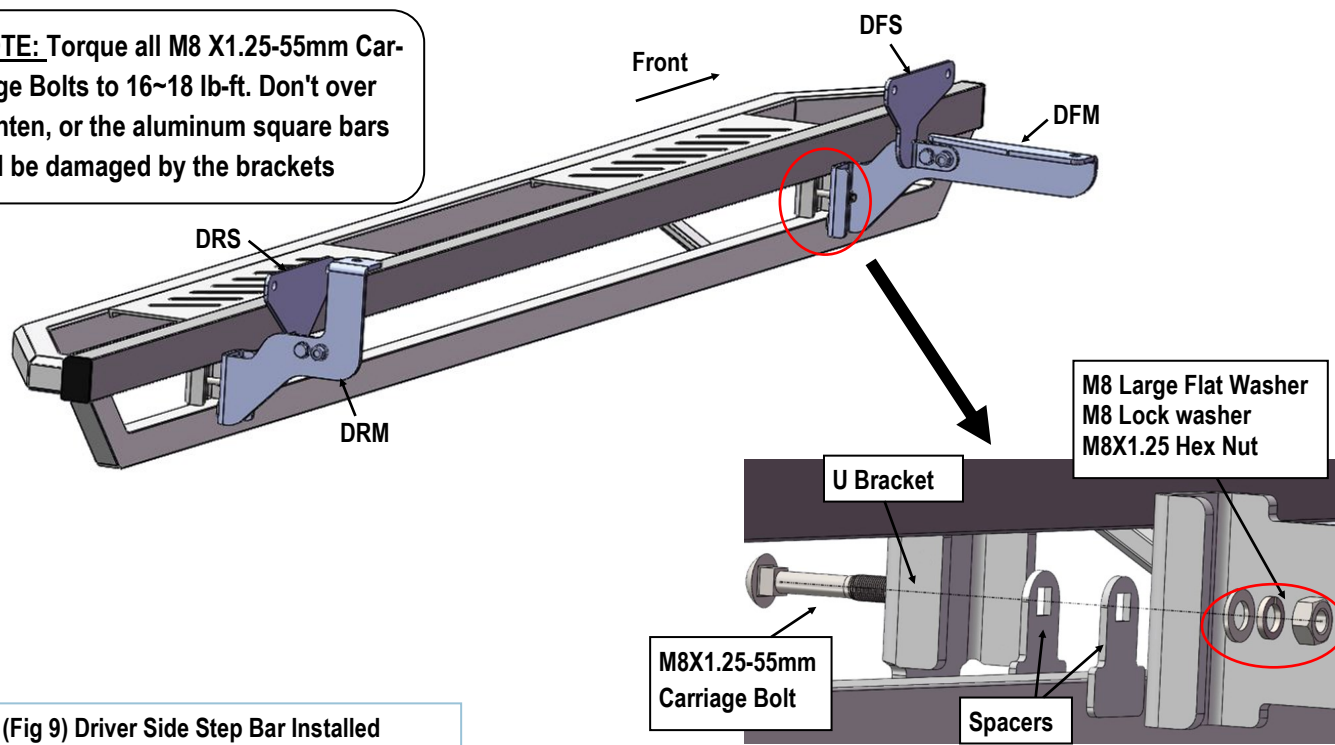

(Fig 9) Driver Side Step Bar Installed