

IARMOR EDGE™

PART#: IA-N913

BEFORE INSTALLATION

REMOVE CONTENTS FROM BOX. VERIFY ALL PARTS ARE PRESENT. READ INSTRUCTIONS CAREFULLY BEFORE STARTING INSTALLATION. ASSISTANCE IS RECOMMENDED. THANK YOU FOR CHOOSING OUR PRODUCT!

*DRILLING NOT REQUIRED

*TRIMMING NOT REQUIRED

Fastener Size	Tightening Torque (ft-lbs)	Required
6mm	6-7	√
8mm	16-18	√
10mm	31-32	√
12mm	56-58	X
14mm	92-94	X

Item	QTY	Description	Item	QTY	Description
1#	2	Driver Front & Rear Mounting Brackets	10#	48	M6 Large Flat Washers
2#	2	Passenger Front & Rear Mounting Brackets	11#	48	M6 Nylon Lock Nuts
3#	4	Support Brackets	12#	4	M8X1.25-35mm Hex Bolts
4#	4	M10 Bolt Plates	13#	8	M8 Flat Washers
5#	4	M10 Plastic Washers	14#	4	M8 Lock Washers
6#	4	M10 Flat Washers	15#	4	M8 Hex Nuts
7#	4	M10 Hex Flange Nuts	16#	8	M6X1-20mm Square Head Bolts
8#	8	M6X1-25mm Hex Bolts	17#	32	M6X1-20mm T-Bolts
9#	8	M6 Flat Washers			

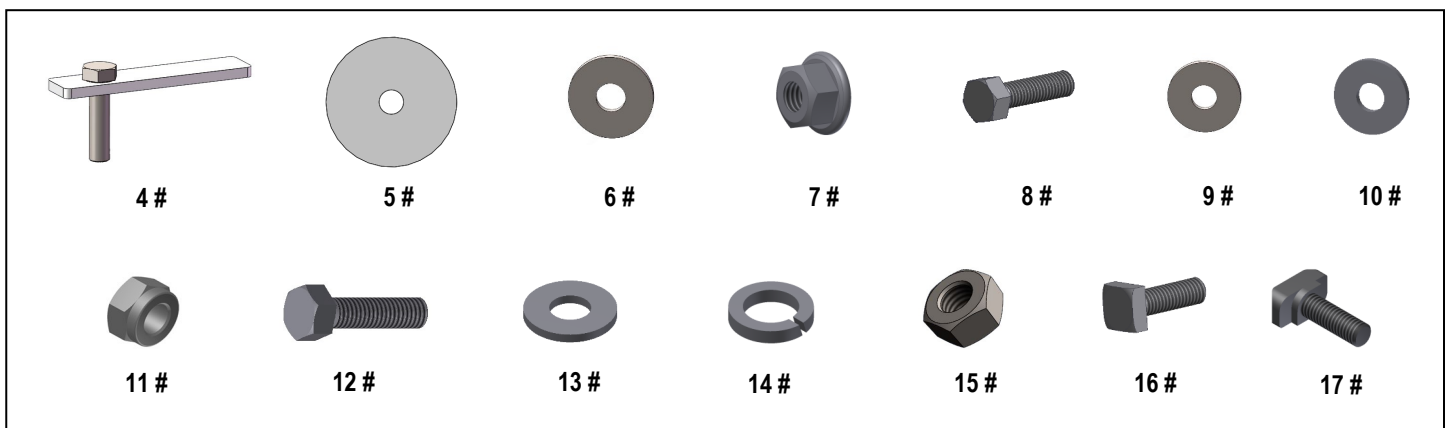

iArmor[®]

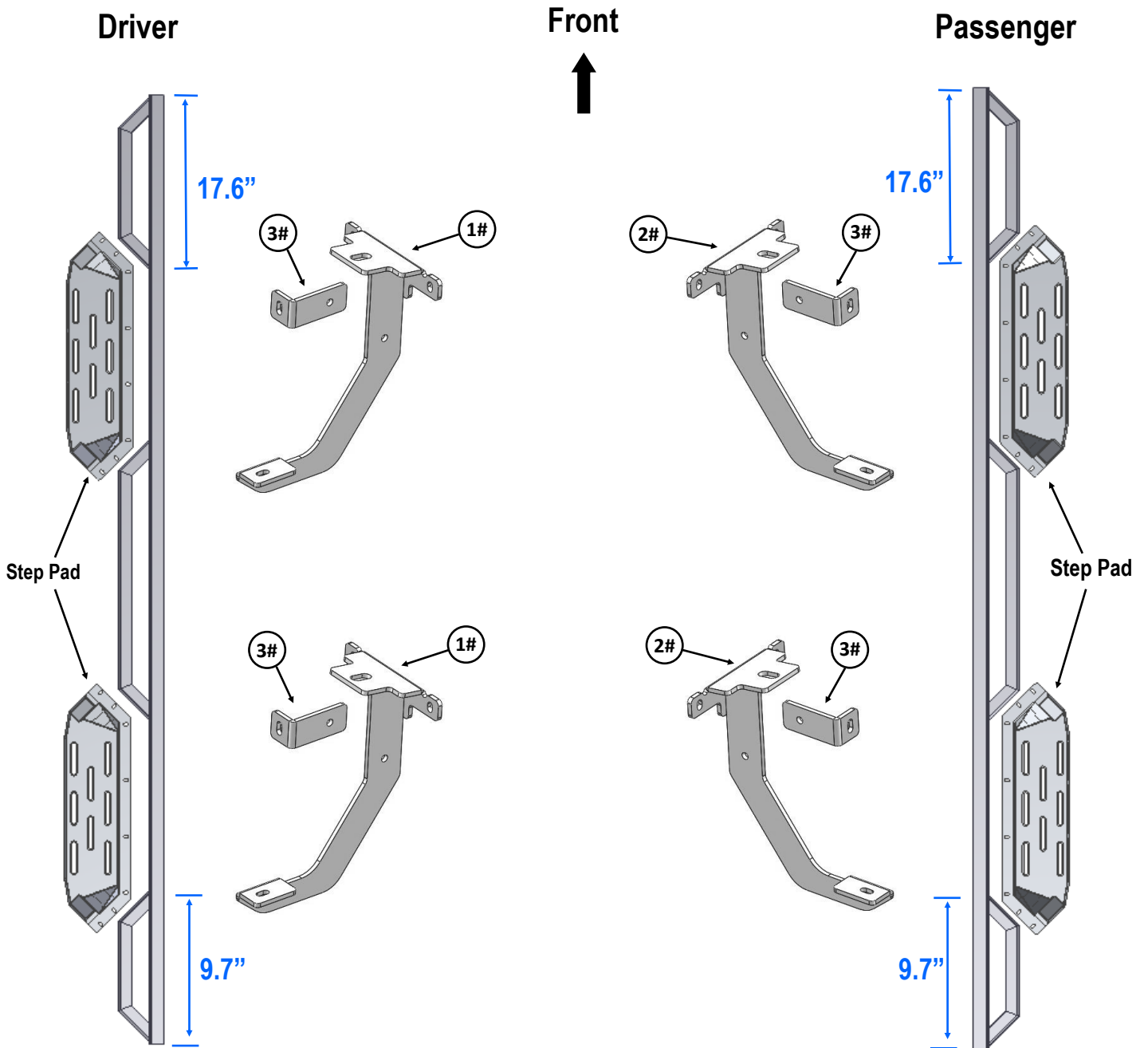

iArmor®

The instruction here is for your reference only. We strongly recommend the professional installer for best result. We are not responsible for any damage caused by the installation.

STEP 1

Install the Step Pads onto the step bars with (32) M6x1-20mm T-Bolts, (32) M6 Flat Washers and (32) M6 Nylon Lock Nuts.

IMPORTANT: Don't hit the step pad by any metal hammer within step pad installation, or the step pad will be damaged.

(8) M6X1-20mm T-Bolts
(8) M6 Flat Washers
(8) M6 Nylon Lock Nuts

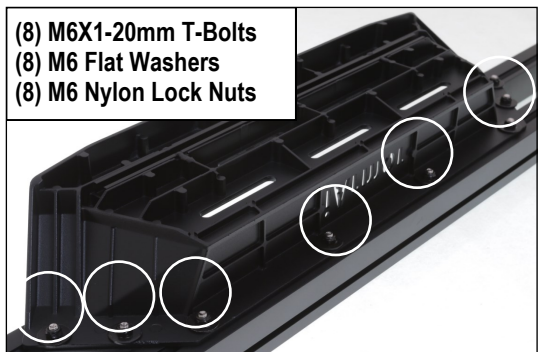

Note: Rotate 90° after inserting the T-Bolts into the Channel!!!

STEP 2

Start installing from the driver side of the vehicle, locate the (2) pairs of factory holes on the pinch weld, (Figs 1 & 2).

Under the Driver Side Front Mounting location, remove the rubber plugs covering the oval hole at the bottom of the rocker panel, (Fig 3).

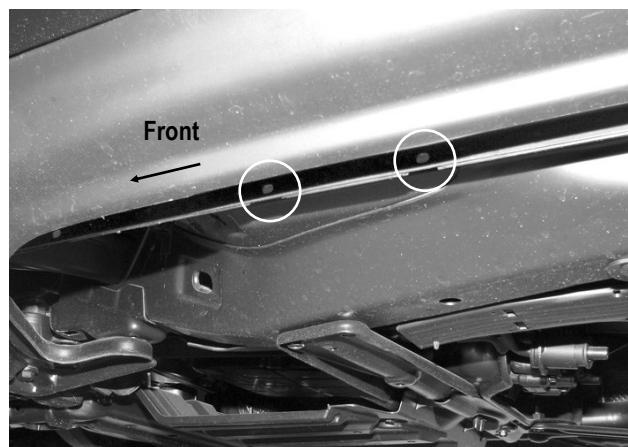

(Fig 1) Drive Front Mounting Bracket Location Pictured

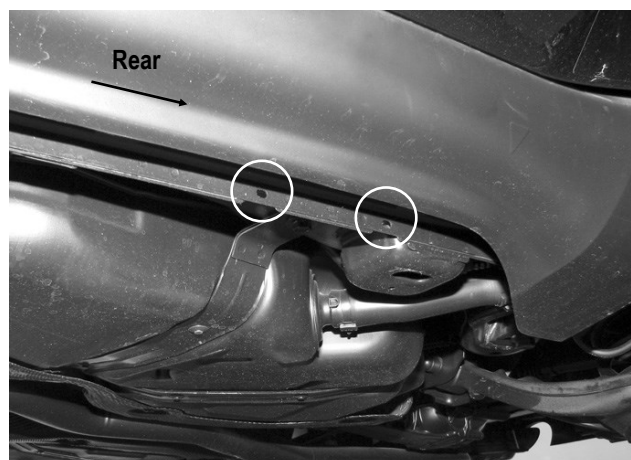

(Fig 2) Driver Rear Mounting Bracket Location Pictured

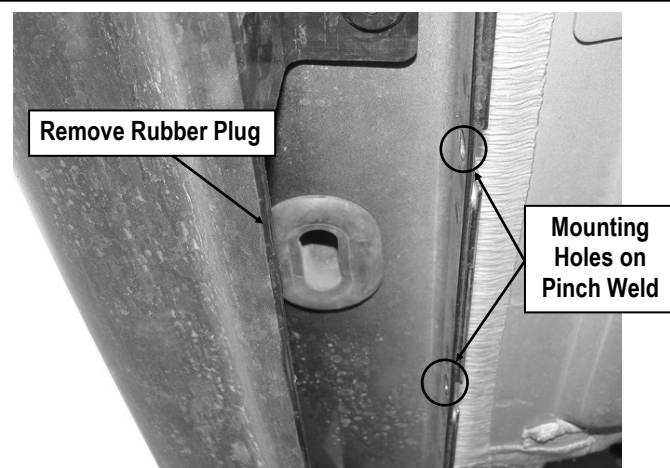

(Fig 3) Driver Side Front Mounting Location

iArmor®

STEP 3

Select (1) M10 Bolt Plate and (1) M10 Plastic Washer. Partially thread the M10 Plastic Washer onto the Welded Bolt. Insert the M10 Bolt Plate into the oval hole and rotate across the slot, **(Fig 4)**. Thread the M10 Plastic Washer all the way down the Welded Bolt and tight against the body panel.

NOTE: The M10 Plastic Washer is designed to prevent the Bolt Plate from falling into the body panel and hold the bolt plate in place within the bracket installation.

After inserting, rotate M10 Bolt Plate across the slot or until M10 Bolt Plate stopped.

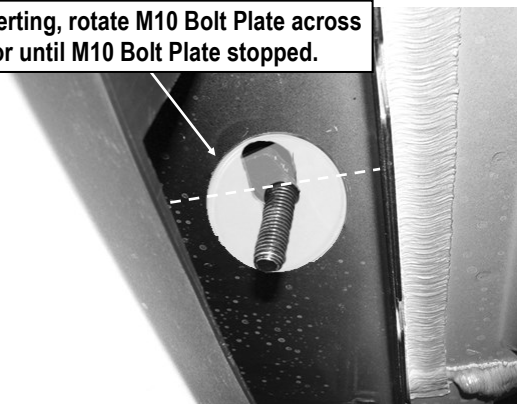

(Fig 4) M10 Bolt Plate Installed on Driver Side Front Mounting Location

STEP 4

Assemble (1) Driver Front Mounting Bracket and (1) Support Bracket with (1) M8X1.25-35mm Hex Bolt, (2) M8 Flat Washers, (1) M8 Lock Washer and (1) M8 Hex Nut, **(Fig 5)**. Do not fully tighten hardware at this time.

STEP 5

Attach the Driver Front Mounting Bracket to the installed M10 Bolt Plate with (1) M10 Flat Washer and (1) M10 Hex Flange Nut, **(Figs 6-8)**.

Line up the (2) small slots on the Driver Front Mounting Bracket with the (2) holes on the pinch weld. Bolt the Driver Front Mounting Bracket to the outside of the pinch weld with (2) M6x1-25mm Hex Bolts, (2) M6 Large Flat Washers (outside against

Bracket) , (2) M6 Flat Washers (inside against pinch weld) and (2) M6 Nylon Lock Nuts, **(Figs 6 –8)**. Do not fully tighten hardware at this time.

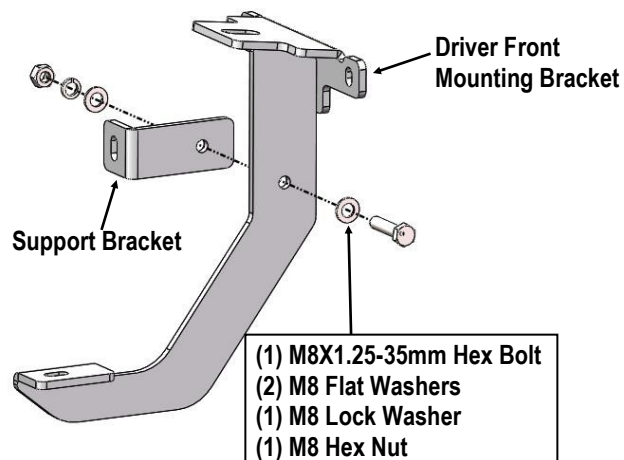

(Fig 5) Driver Side Front Mounting Bracket Assembly

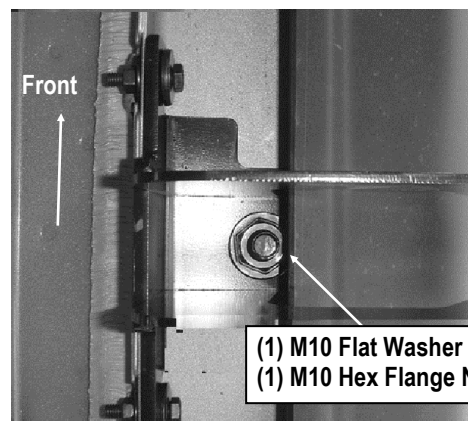

(Fig 6) Driver Front Mounting Bracket Installation

- (2) M6x1-25mm Hex Bolts
- (2) M6 Large Flat Washers (outside)
- (2) M6 Flat Washers (inside)
- (2) M6 Nylon Lock Nuts

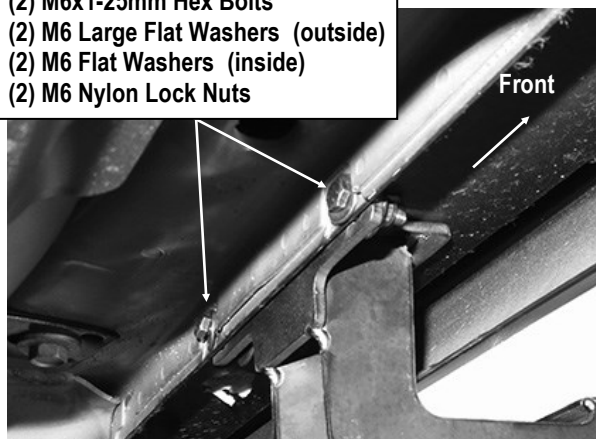

(Fig 7) Driver Front Mounting Bracket Installation

- (2) M6x1-25mm Hex Bolts
- (2) M6 Large Flat Washers (outside)
- (2) M6 Flat Washers (inside)

- (1) M10 Flat Washer
- (1) M10 Hex Flange Nut

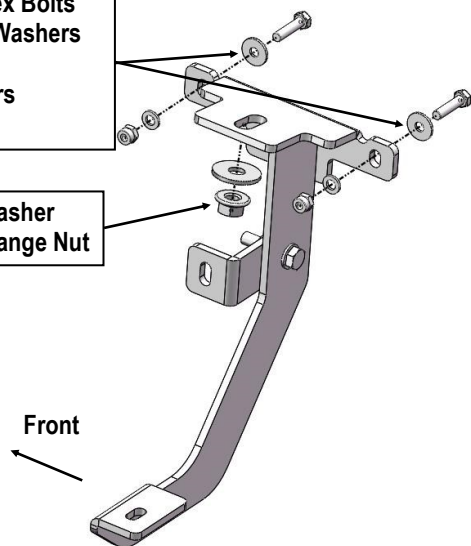

(Fig 8) Driver Front Mounting Bracket Installation

STEP 6

Repeat **Steps 2-5** to install and assemble the Driver Rear Mounting Bracket and the Support Bracket. Do not fully tighten hardware at this time.

Note: Driver Front Mounting Bracket & Driver Rear Mounting Brackets are universal.

STEP 7

Once all (2) Driver side brackets are installed, select and attach the assembled Driver Side Step Bar onto the Mounting Brackets with (4) M6X1-20mm Square Head Bolts, (4) M6 Large Flat Washers and (4) M6 Nylon Lock Nuts, (**Fig 9**). Do not fully tighten hardware at this time.

STEP 8

Properly level and adjust the Step Bar and fully tighten all hardware.

STEP 9

Move to the other side of the vehicle. Repeat **Steps 2—8** for other side Step Bar installation.

Attention

Do periodic inspections to the installation to make sure that all hardware is secure and tight.

In order to protect your bars/boards, please use only mild soap/non-abrasive products for cleaning.

iArmor[®]

(Fig 9) Driver Side Step Bar Installation

