

IARMOR EDGE™

PART#: IA-N912

BEFORE INSTALLATION

REMOVE CONTENTS FROM BOX. VERIFY ALL PARTS ARE PRESENT. READ INSTRUCTIONS CAREFULLY BEFORE STARTING INSTALLATION. ASSISTANCE IS RECOMMENDED. THANK YOU FOR CHOOSING OUR PRODUCT!

*DRILLING NOT REQUIRED

*TRIMMING NOT REQUIRED

Fastener Size	Tightening Torque (ft-lbs)	Required
6mm	6-7	√
8mm	16-18	√
10mm	31-32	√
12mm	56-58	X
14mm	92-94	X

Item	QTY	Description	Item	QTY	Description
1#	2	Driver / Passenger Front Mounting Brackets	10#	4	M10 Hex Nuts
2#	1	Driver Rear Mounting Bracket	11#	4	M10 Rivet Nuts
3#	1	Passenger Rear Mounting Bracket	12#	2	M8X1.25-30mm Hex Bolts
4#	1	Driver Rear Support Bracket	13#	4	M8 Flat Washers
5#	1	Passenger Rear Support Bracket	14#	2	M8 Nylon Lock Nuts
6#	4	M10X35 Bolt Plates	15#	36	M6X1-20mm T-Bolts
7#	4	M10X1.5-25mm Hex Bolts	16#	4	M6X1-20mm Square Head Bolts
8#	8	M10 Flat Washers	17#	40	M6 Large Flat Washers
9#	8	M10 Lock Washers	18#	40	M6 Nylon Lock Nuts

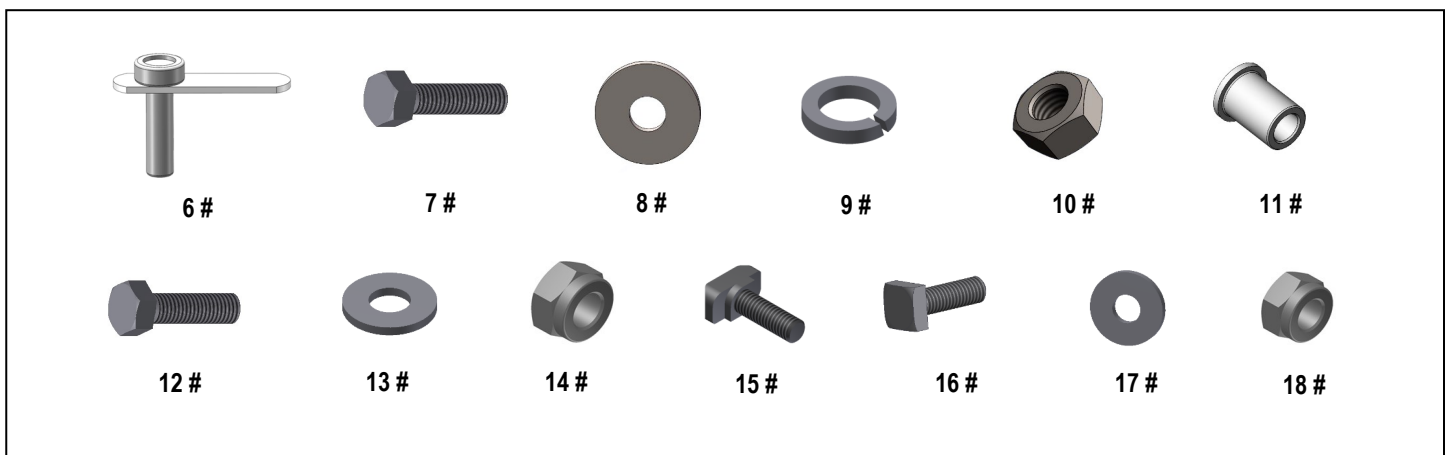

iArmor[®]

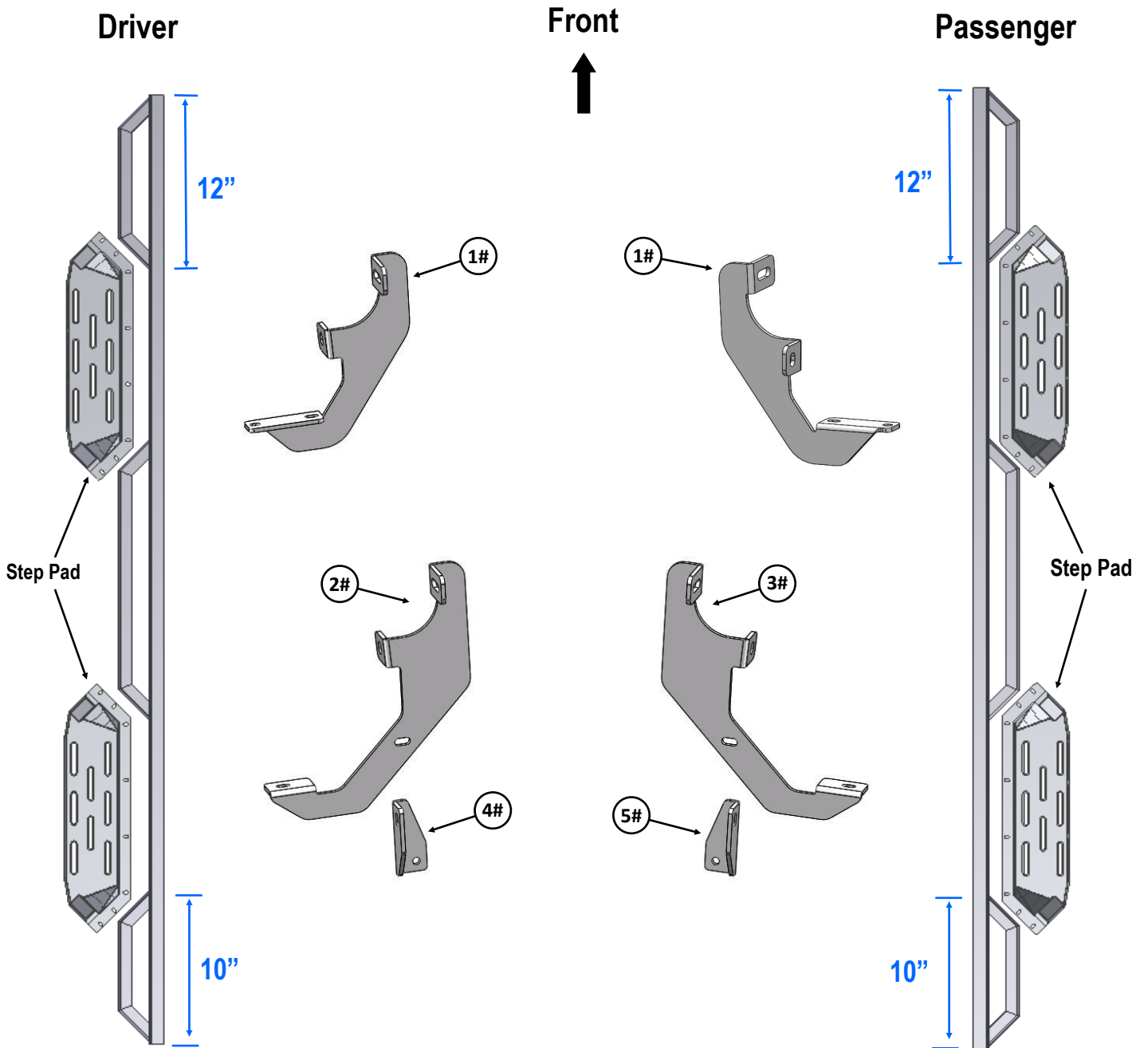

iArmor®

The instruction here is for your reference only. We strongly recommend the professional installer for best result. We are not responsible for any damage caused by the installation.

STEP 1

Install the Step Pads onto the step bars with (32) M6x1-20mm T-Bolts, (32) M6 Flat Washers and (32) M6 Nylon Lock Nuts.

IMPORTANT: Don't hit the step pad by any metal hammer within step pad installation, or the step pad will be damaged.

(8) M6X1-20mm T-Bolts
(8) M6 Flat Washers
(8) M6 Nylon Lock Nuts

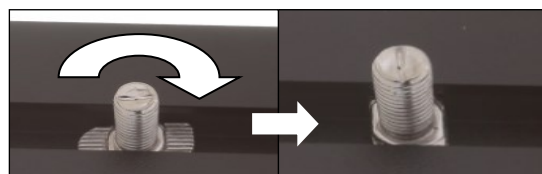
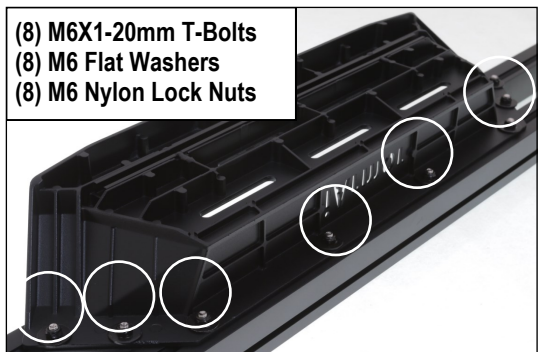

Note: Rotate 90° after inserting the T-Bolts into the Channel!!!

STEP 2

Start installation from the driver side front of the vehicle. Separate trim from rocker panel to insert M10x35 Bolt Plate as shown. Leave hardware loose at this time, (Figs 1 & 2).

Then, insert M10 Rivet Nut to a hex hole on rocker panel as shown, (Fig 2).

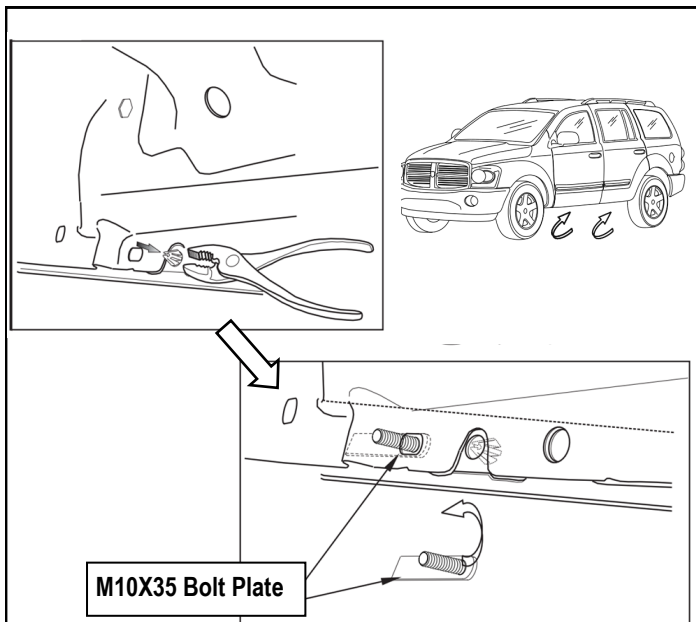

(Fig 1) Insert M10x35 Bolt Plate

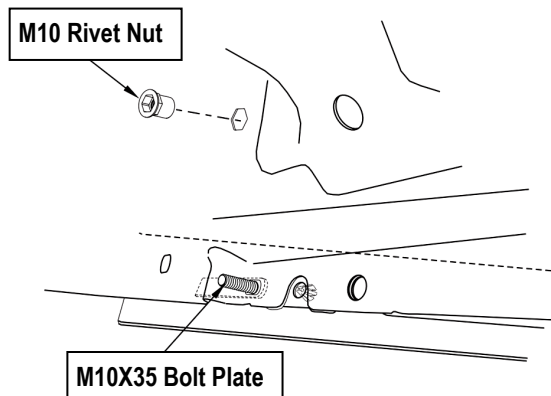

(Fig 2) Insert M10 Rivet Nut

STEP 3

Attach the Driver Front Mounting Bracket to the installed M10 Rivet Nut with (1) M10X1.5-25mm Hex Bolt, (1) M10 Lock Washer and (1) M10 Flat Washer; to the installed M10x35 Bolt Plate with (1) M10 Flat Washer, (1) M10 Lock Washer and (1) M10 Hex Nut, (Fig 3). Do not fully tighten hardware at this time.

iArmor®

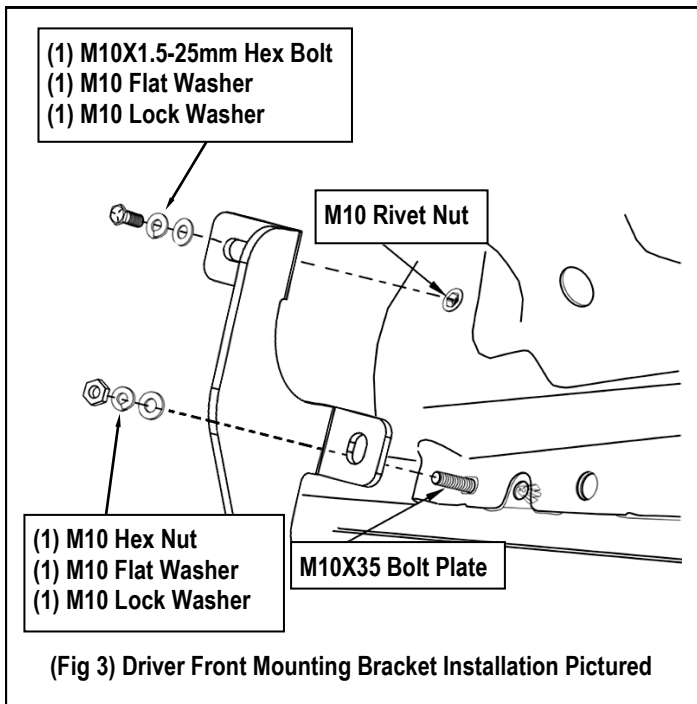

STEP 4

Tighten top bolt to crimp Rivet Nut until increased resistance is felt. Verify M10 Rivet Nut is not loose in hole, otherwise re-tighten. Hole M10x35 Bolt Plate parallel to rocker panel and tighten bottom nut. Re-attach trim panel.

NOTE: BRACKET MUST BE HELD FLUSH AGAINST ROCKER PANEL WHILE TIGHTENING TOP BOLT OR THE M10 RIVET NUT WILL NOT SEAT PROPERLY.

STEP 5

Move to the driver side rear mounting location. Select (1) Driver Rear Mounting Bracket and (1) Driver Rear Support Bracket. Assemble with (1) M8X1.25-30mm Hex Bolt, (2) M8 Flat Washers and (1) M8 Nylon Lock Nut, (Fig 4). Do not fully tighten hardware at this time.

Repeat **Steps 2-4** for driver side rear brackets installation.

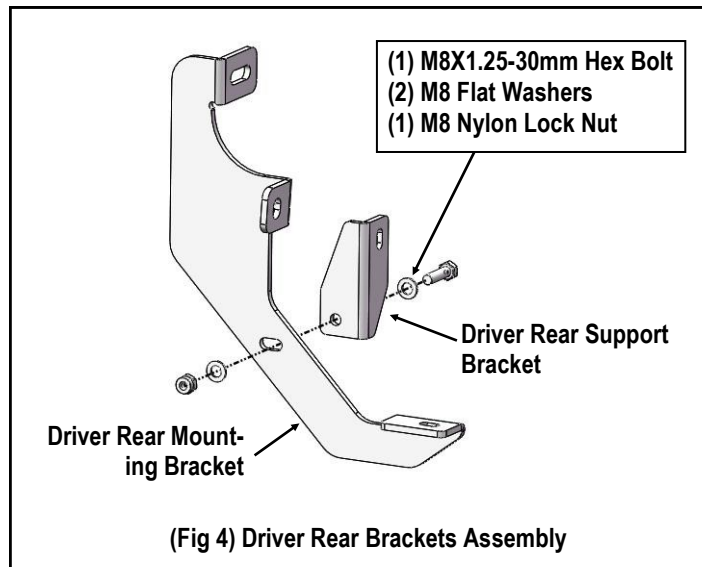

STEP 6

Once all (2) driver side brackets are installed, select and attach the assembled Driver Side Step Bar onto the Mounting Brackets with (2) M6X1-20mm T-Bolts, (2) M6X1-20mm Square Head Bolts, (4) M6 Large Flat Washers and (4) M6 Nylon Lock Nuts, (Fig 5). Do not fully tighten hardware at this time.

STEP 7

Properly level and adjust the Step Bar and fully tighten all hardware.

STEP 8

Move to the other side of the vehicle. Repeat **Steps 2—7** for other side Step Bar installation.

Attention

Do periodic inspections to the installation to make sure that all hardware is secure and tight.

In order to protect your bars/boards, please use only mild soap/non-abrasive products for cleaning.

iArmor[®]

(Fig 5) Driver Side Step Bar Installed

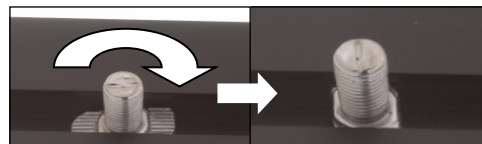

Warning: Install the T-bolt on the step bar and rotate it to 90 degrees!!!

